

**SRI CHANDRASEKHARENDRA SARASWATHI VISWA  
MAHAVIDYALAYA**  
(University U/S 3 of UGC Act 1956)  
Accredited with “A” Grade by NAAC  
**ENATHUR, KANCHIPURAM - 631561**



**DEPARTMENT : EIE/MECHATRONICS**  
**YEAR/SEM : IV/ VIII**  
**SUBJECT : BIOMEDICAL INSTRUMENTATION**  
**SUBJECT CODE : EI8T2**  
**UNIT : I TO V**

**Prepared by**

**S. S. SARAVANA KUMAR,**

**Assistant Professor**  
**Department of Electronics and Instrumentation Engineering**  
**Sri Chandrasekharendra Saraswathi Viswa Mahavidyalaya**  
**Enathur, Kanchipuram - 631561**

## **BIOMEDICAL INSTRUMENTATION**

### **Aim**

To make the student understand about the construction, working and operation of various biomedical instruments.

### **Objectives**

The course will enable the students to:

1. Understand the Physiology of the heart, lung, blood circulation and respiration including different transducers used.
2. Learn about various sensing and measurement devices of electrical and non-electrical origin.
3. Understand modern methods of imaging techniques.
4. Study about medical assistance techniques and therapeutic equipments

### **Outcome**

At the end of this course the students should be able to:

1. Know the basic concepts of Anatomy & Physiology
2. Have adequate knowledge about different types of Electrodes, Transducers and Amplifiers
3. Understand the important and modern methods of imaging techniques
4. Comprehend about the Human Assist Devices and Therapeutic Equipments

### **UNIT -I FUNDAMENTALS OF BIOMEDICAL ENGINEERING**

Cell and its structure – Resting and Action Potential – Nervous system and its fundamentals - Basic components of a biomedical system- Cardiovascular systems- Respiratory systems -Kidney and blood flow - Biomechanics of bone - Biomechanics of soft tissues - Basic mechanics of spinal column and limbs -Physiological signals and transducers - Transducers – selection criteria – Piezo electric, ultrasonic transducers - Temperature measurements - Fibre optic temperature sensors.

### **UNIT- II NON ELECTRICAL PARAMETERS MEASUREMENT AND DIAGNOSTIC PROCEDURES**

Measurement of blood pressure - Cardiac output - Heart rate - Heart sound - Pulmonary function measurements – spirometer – Photo Plethysmography, Body Plethysmography – Blood Gas analysers, pH of blood –measurement of blood pCO<sub>2</sub>, pO<sub>2</sub>, finger-tip oxymeter - ESR, GSR measurements.

### **UNIT -III ELECTRICAL PARAMETERS ACQUISITION AND ANALYSIS**

Electrodes – Limb electrodes –floating electrodes – pregelled disposable electrodes - Micro, needle and surface electrodes – Amplifiers, Preamplifiers, differential amplifiers, chopper amplifiers – Isolation amplifier - ECG – EEG – EMG – ERG – Lead systems and recording methods – Typical waveforms - Electrical safety in medical environment, shock hazards – leakage current-Instruments for checking safety parameters of biomedical equipments.

### **UNIT -IV IMAGING MODALITIES AND ANALYSIS**

Radio graphic and fluoroscopic techniques – Computer tomography – MRI – PET-SPECT- Ultrasonography – Endoscopy – Thermography –Different types of biotelemetry systems - Retinal Imaging - Imaging application in Biometric systems - Analysis of digital images

### **UNIT- V LIFE ASSISTING, THERAPEUTIC AND ROBOTIC DEVICES**

Pacemakers – Defibrillators – Ventilators – Nerve and muscle stimulators – Diathermy – Heart – Lung machine – Audio meters – Dialysers – Lithotripsy - ICU patient monitoring system - Nano Robots - Robotic surgery – Advanced 3D surgical techniques- Orthopedic prostheses fixation.

### **TEXT BOOKS:**

1. Leslie Cromwell, Biomedical Instrumentation and Measurement, Prentice hall of India, New Delhi,2007.
2. M.Arumugam, 'Bio-Medical Instrumentation', Anuradha Agencies, 2003.
3. Khandpur R.S, Handbook of Biomedical Instrumentation, , Tata McGraw-Hill, New Delhi, 2 Edition, 2003.

### **REFERENCES:**

1. John G. Webster, Medical Instrumentation Application and Design, John Wiley and sons, NewYork, 1998.
2. Duane Knudson, Fundamentals of Biomechanics, Springer, 2nd Edition, 2007.
3. Suh, Sang, Gurupur, Varadraj P., Tanik, Murat M., Health Care Systems, Technology and Techniques, Springer, 1st Edition, 2011.
4. Ed. Joseph D. Bronzino, The Biomedical Engineering Hand Book, Third Edition, Boca Raton, CRC Press LLC, 2006.
5. Joseph J.carr and John M. Brown, Introduction to Biomedical Equipment Technology, John Wiley and sons, New York, 4th Edition, 2012.

**UNIT -I**  
**FUNDAMENTALS OF BIOMEDICAL ENGINEERING**

**AIM**

To know the basic concepts of Anatomy & Physiology

**PRE MCQ:**

1. Which type of transducer requires energy to be put into it in order to translate changes due to the measurand?
  - a) Active transducers
  - b) Passive transducers
  - c) Powered transducers
  - d) Local transducersAnswer: b
2. Active transducers work on the principle of \_\_\_\_\_
  - a) Energy conversion
  - b) Mass conversion
  - c) Energy alteration
  - d) Volume conversionAnswer: a
3. Accuracy is \_\_\_\_\_
  - a) Ability of the transducer or sensor to see small differences in reading
  - b) Ability of the transducer or sensor to see small differences in reading
  - c) Algebraic difference between the indicated value and the true or theoretical value of the measurand
  - d) Total operating range of the transducerAnswer: c
4. The smallest change in measurand that will result in a measurable change in the transducer output is called \_\_\_\_\_
  - a) Offset
  - b) Linearity
  - c) Resolution
  - d) ThresholdAnswer: d
5. Unwanted signal at the output due either to internal sources or to interference is called \_\_\_\_\_
  - a) Offset
  - b) Noise
  - c) Drift
  - d) ThresholdAnswer: b
6. The ability of the sensor to see small differences in reading is called \_\_\_\_\_
  - a) Resolution
  - b) Drift
  - c) Offset
  - d) LinearityAnswer: a
7. Change in signal over long period of time is called \_\_\_\_\_
  - a) Noise
  - b) Offset
  - c) Hysteresis
  - d) DriftAnswer: d

## **THEORY:**

Cell and its structure – Resting and Action Potential – Nervous system and its fundamentals – Basic components of a biomedical system- Cardiovascular systems- Respiratory systems -Kidney and bloodflow - Biomechanics of bone - Biomechanics of soft tissues - Basic mechanics of spinal column and limbs -Physiological signals and transducers - Transducers – selection criteria – Piezo electric,ultrasonic transducers - Temperature measurements - Fibre optic temperature sensors.

## **Cell and its Structure**

### **Cell theory:**

All living things are composed of cells. Cells are the basic units of life and all tissues and organs are composed of cells. They are so small that they must be viewed with a microscope. There are different types of cells.

Cells can either be **eukaryotic** or **prokaryotic**.

Eukaryotic cells have a nucleus and membrane bound organelles. Plant and animal cells are eukaryotes. Plant cells are generally a square shape while animal cells are usually circular. Plant cells and animal cells have evolved different organelles to perform specific functions. Plant cells have chloroplasts, a cell wall and a central vacuole. Animal cells lack these three organelles. Plant cells have chloroplasts because they make their own food. Plant cells have a cell wall so that they do not burst when the central vacuole fills up with water. Prokaryotes do not have a nucleus, and lack membrane bound organelles. They are the oldest cells on earth. Bacteria are prokaryotes. Prokaryotes often move using special structures such as flagella or cilia.

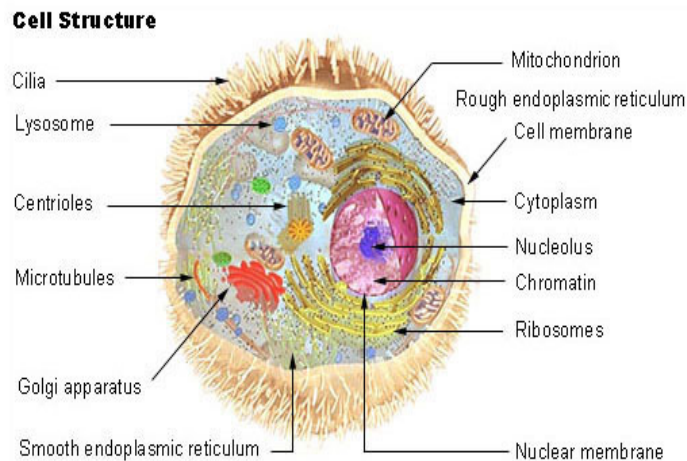

Cells have many structures inside of them called organelles. These organelles are like the organs in a human and they help the cell stay alive. Each organelle has its own specific function to help the cell survive. The nucleus of a eukaryotic cell directs the cell's activities and stores DNA. Eukaryotes also have a Golgi apparatus that packages and distributes proteins. Mitochondria are the power house of the cell and provide the cell with energy. Both plant and animal cells have mitochondria. Lysosomes are like the stomach of the cell. They contain enzymes that digest the cell's used parts. All of the cell's organelles must work together to keep the cell healthy.

The cell membrane is the protective barrier that surrounds the cell and prevents unwanted material from getting into it. The cell membrane has many functions, but one main function that it has is to transport materials (salts, electrolytes, glucose and other necessary molecules) into the cell to support necessary life functions. Not only does the membrane let molecules into the cell, but it also lets wastes such as carbon dioxide out of the cell. The cell membrane is made up of a phospholipid bilayer. Each phospholipid contains a hydrophilic, or water loving head and a hydrophobic, or water fearing tail. These properties that the phospholipids have and the specific orientation they are arranged in provide the cell with a selectively permeable barrier.



## Resting and Action Potential

### Sources of Bioelectric Potential

- The systems in the human body generate their own monitoring signals when they carry out their functions.
- These signals provide useful information about their function.
- These signals are bioelectric potentials associated with nerve conduction, brain activity, heartbeat, muscle activity and so on.
- Bioelectric potentials are actually ionic voltages produced as a result of electro chemical activity of certain cell.

Transducers are used to convert these ionic potentials into electrical signals

### Resting and Action potentials

#### Resting Potential [Polarization]

- Certain types of cells within the body, such as nerve and muscle cells are encased in a semi permeable membrane. This membrane permits some substances to pass through while others are kept out. Surrounding the cells of the body are the body fluids. These fluids are conductive solutions containing charged atoms known as ions.
- The principle ions are sodium ( $\text{Na}^+$ ) Potassium ( $\text{K}^+$ ) and chloride ( $\text{Cl}^-$ ). The membrane of excitable cells permits entry of Potassium ( $\text{K}^+$ ) and chloride ( $\text{Cl}^-$ ) ions but blocks the entry of sodium ( $\text{Na}^+$ ) ions. So inside the cell is more negative than outside cell. This membrane potential is called Resting potentials. This potential is measured from inside the cell with respect to body fluids. So resting potential of a cell is negative.
- This resting potential ranging from **-60mv to -100 mv.**
- Cell in the **resting state is called polarized cell.**

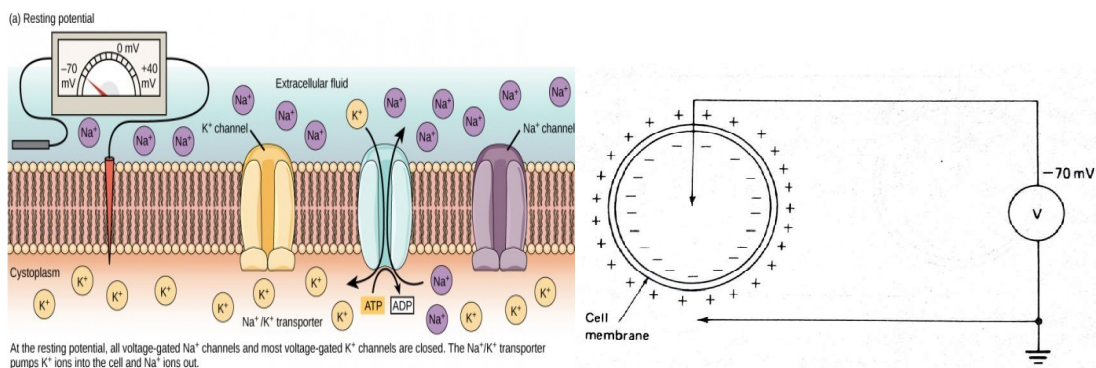

#### Action Potential [Depolarization]

- When a section of a cell membrane is excited by the flow of ionic current or by some form of externally applied energy, the membrane allows some  $\text{Na}^+$  and try to reach some balance of potential inside and outside. Same time the some  $\text{K}^+$  goes outside but not rapidly like sodium.
- As a result, the cell has slightly Positive potential on the inside Due to the imbalance of the Potassium ions. This potential is known as “action potential” and is approximately +20 mV.
- A cell that has been excited and that displays an action potential is said to be depolarized and process from resting to action potential is called depolarization

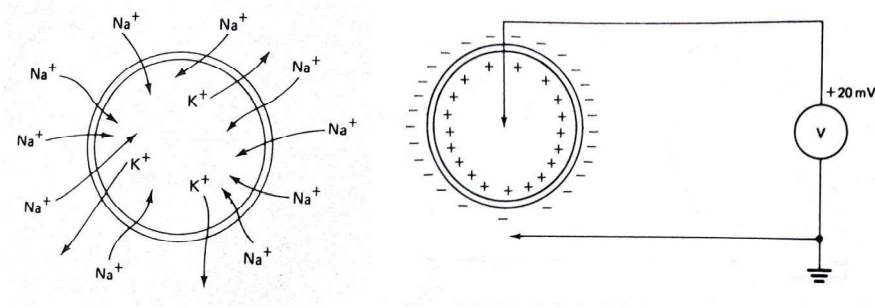

### Propagation of action potentials

- When a cell is excited and generates an action potential, ionic currents flow. This process excites neighbouring cells or adjacent areas of the same cell.
- The rate at which an action potential moves down a fiber or is propagated from cell to cell is called the propagation rate.
- In a nerve fiber, the propagation rate is also called the nerve conduction rate, or conduction velocity. Velocity ranges in nerves are from 20 to 140 meters per second. In heart muscle, the rate is slower, average 0.2 to 0.4 m/sec.

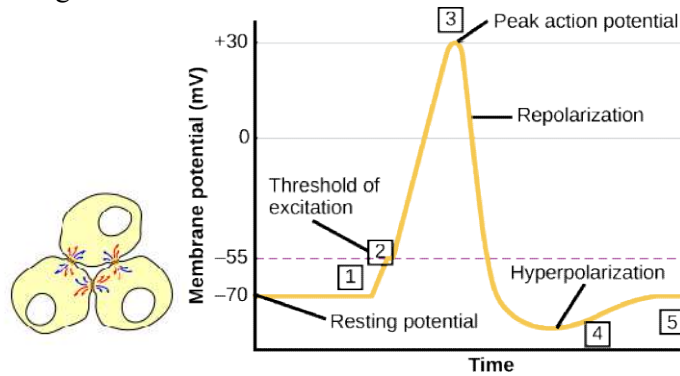

### The formation of an action potential in 5 stages

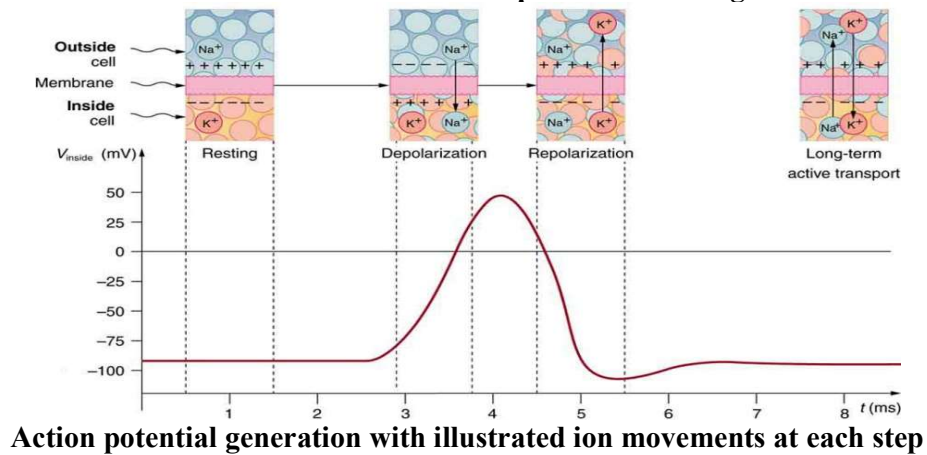

### The Bioelectric Potentials

- The Electrocardiogram (ECG)
- The Electroencephalogram (EEG)
- The Electromyogram (EMG)
- The Electroretinogram (ERG)
- The Electro-oculogram (EOG)
- The Electrogastragram (EGG)

## Nervous system and its fundamentals

- The nervous system is the master controlling and communicating system of the body. Every thought, action, and emotion reflect its activity. Its cells communicate by electrical and chemical signals, which are rapid and specific, and usually cause almost immediate responses
- The nervous system is a network of neurons whose main feature is to generate, modulate and transmit information between all the different parts of the human body. This property enables many important functions of the nervous system, such as regulation of vital body functions (heartbeat, breathing, digestion), sensation and body movements.
- The nervous system structures preside over everything that makes us human; our consciousness, cognition, behaviour and memories.

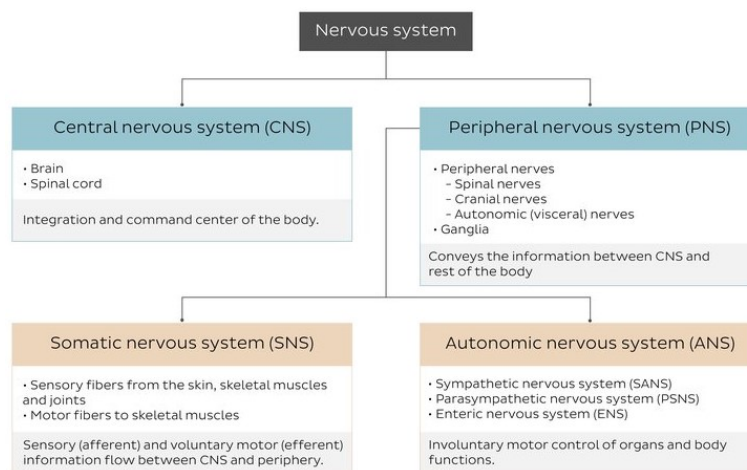

The nervous system comprised of two main parts:

- **Central nervous system (CNS)** is the integration and command center of the body.
- **Peripheral nervous system (PNS)** represents the conduit between the CNS and the body. It is further subdivided into the **Somatic nervous system (SNS)** and the **Autonomic nervous system (ANS)**

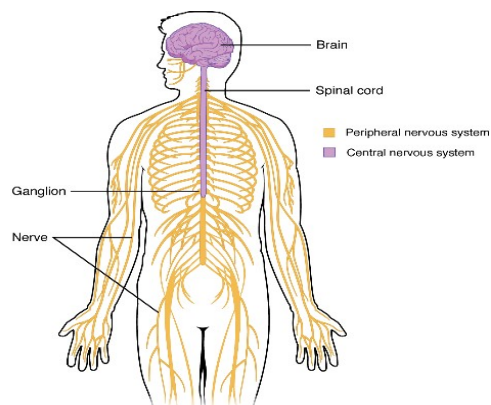

The **Central nervous system (CNS)** consists of the brain and spinal cord. These are found housed within the skull and vertebral column respectively.

The brain is made of four parts:

**Cerebrum diencephalon**

## **cerebellum brainstem.**

Together these parts process the incoming information from peripheral tissues and generate commands; telling the tissues how to respond and function. These commands tackle the most complex voluntary and involuntary human body functions, from breathing to thinking.

The spinal cord continues from the brainstem. It also has the ability to generate commands but for involuntary processes only, i.e., reflexes. However, its main function is to pass information between the CNS and periphery.

- **The Peripheral nervous system (PNS)** consists of 12 pairs of cranial nerves, 31 pairs of spinal nerves and a number of small neuronal clusters throughout the body called ganglia. Peripheral nerves can be sensory (afferent), motor (efferent) or mixed (both). Depending on what structures they innervate, peripheral nerves can have the following modalities;
  - Special - innervating special senses (e.g., eye) and is found only in afferent fibers
  - General - supplying everything except special senses
  - Somatic - innervates the skin and skeletal muscles (e.g., biceps brachii)
  - Visceral - supplies internal organs.
  - It is classified into two types:
    - a. Somatic Nervous System
    - b. Autonomic Nervous Systems

### **(a) The somatic nervous system**

- The **somatic system** is the part of the peripheral nervous system **responsible for carrying sensory and motor information to and from the central nervous system.**
- This system contains two major types of neurons:
- **Sensory neurons** (or afferent neurons) that carry information from the nerves to the central nervous system.
- **Motor neurons** (or efferent neurons) that carry information from the **brain and spinal cord to muscle fibers throughout the body.**

### **(b) Autonomic Nervous systems**

- The autonomic system is the part of the peripheral nervous system responsible for regulating involuntary (reflex/Un intentional) body functions, such as blood flow, heartbeat, digestion and breathing.
- This system is further divided into two branches:
- The sympathetic system regulates the flight-or-flight responses.
- The "fight or flight response" is our body's primitive, automatic, inborn response that prepares the body to "fight" or "flee" from perceived attack, harm or threat to our survival.
- Parasympathetic system helps maintain normal body functions and conserves physical resources

## **Basic components of a biomedical system**

### **Biomedical Instrumentation**

It involves measurement of biological signals like ECG, EMG, or any electrical signals generated in the human body. Biomedical Instrumentation helps physicians to diagnose the problem and provide treatment. To measure biological signals and to design a medical instrument, concepts of electronics and measurement techniques are needed.

### **Components of Biomedical Instrumentation System**

Any medical instrument consists of the following functional basic parts :

**1. Measurand:** The measurand is the physical quantity, and the instrumentation systems measure it. Human body acts as the source for measurand, and it generates bio-signals. Example: body surface or blood pressure in the heart.

**2. Sensor / Transducer:** The transducer converts one form of energy to another form usually electrical energy. For example, the piezoelectric signal which converts mechanical vibrations into the electrical signal. The transducer produces a usable output depending on the measurand. The sensor is used to sense the signal from the source. It is used to interface the signal with the human.

**3. Signal Conditioner:** Signal conditioning circuits are used to convert the output from the transducer into an electrical value. The instrument system sends this quantity to the display or recording system. Generally, signal conditioning process includes amplification, filtering, analogue to digital and Digital to analogue conversions. Signal conditioning improves the sensitivity of instruments.

**4. Display:** It is used to provide a visual representation of the measured parameter or quantity. Example: Chart recorder, Cathode Ray oscilloscope (CRO). Sometimes alarms are used to hear the audio signals. Example: Signals generated in Doppler Ultrasound Scanner used for Fatal Monitoring.

**5. Data Storage and Data Transmission:** Data storage is used to store the data and can be used for future reference. Recent days Electronic Health records are utilized in hospitals. Data transmission is used in Telemetric systems, where data can be transmitted from one location to another remotely.

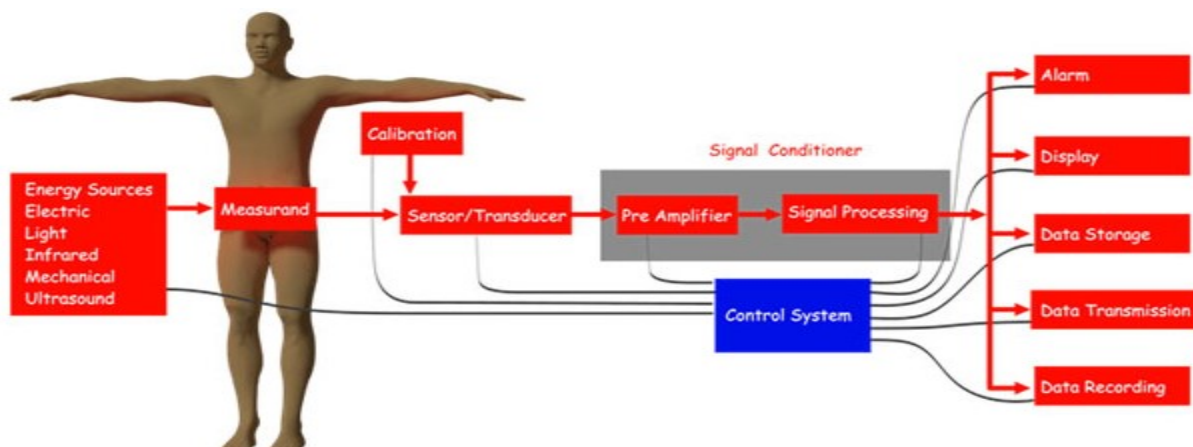

## Cardiovascular systems

- The cardiovascular system is sometimes called the blood-vascular, or simply the circulatory system. It consists of the heart, which is a muscular pumping device, and a closed system of vessels called arteries, veins, and capillaries. As the name implies, blood contained in the circulatory system is pumped by the heart around a closed circle or circuit of vessels as it passes again and again through the various "circulations" of the body.
- The vital role of the cardiovascular system in maintaining homeostasis depends on the continuous and controlled movement of blood through the thousands of miles of capillaries that permeate every tissue and reach every cell in the body. It is in the microscopic capillaries that blood performs its ultimate transport function. Nutrients and other essential materials pass from capillary blood into fluids surrounding the cells as waste products are removed.
- Numerous control mechanisms help to regulate and integrate the diverse functions and component parts of the cardiovascular system in order to supply blood to specific body areas



according to need. These mechanisms ensure a constant internal environment surrounding each body cell regardless of differing demands for nutrients or production of waste products.

## Heart

- The heart is a muscular pump that provides the force necessary to circulate the blood to all the tissues in the body. Its function is vital because, to survive, the tissues need a continuous supply of oxygen and nutrients, and metabolic waste products have to be removed. Deprived of these necessities, cells soon undergo irreversible changes that lead to death. While blood is the transport medium, the heart is the organ that keeps the blood moving through the vessels. If it loses its pumping effectiveness for even a few minutes, the individual's life is

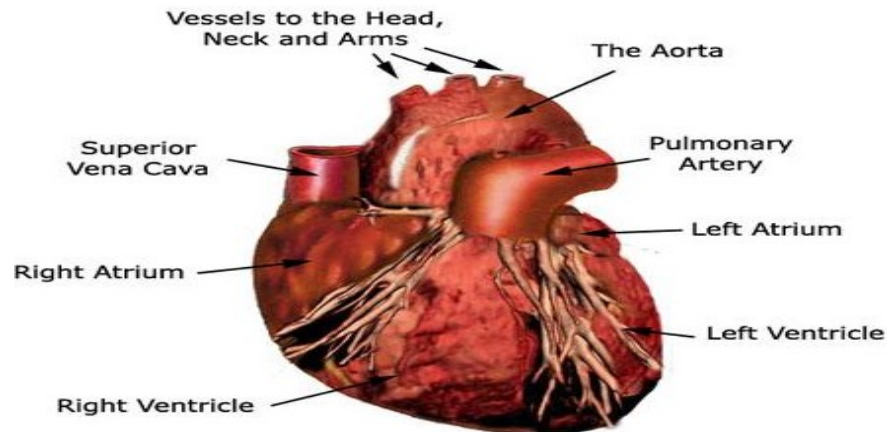

jeopardized

## Structure and Function of the Heart

**Function and Location of the Heart:** The heart's job is to pump blood around the body. The heart is located in between the two lungs. It lies left of the middle of the chest.

**Structure of the Heart:** The heart is a muscle about the size of a fist, and is roughly cone-shaped. It is about 12cm long, 9cm across the broadest point and about 6cm thick. The pericardium is a fibrous covering which wraps around the whole heart. It holds the heart in place but allows it to move as it beats. The wall of the heart itself is made up of a special type of muscle called cardiac muscle.

**Chambers of the Heart:** The heart has two sides, the right side and the left side. The heart has four chambers. The left and right side each have two chambers, a top chamber and a bottom chamber. The two top chambers are known as the left and right atria (singular: atrium). The atria receive blood from different sources. The left atrium receives blood from the lungs and the right atrium receives blood from the rest of the body. The bottom two chambers are known as the left and right ventricles. The ventricles pump blood out to different parts of the body. The right ventricle pumps blood to the lungs while the left ventricle pumps out blood to the rest of the body. The ventricles have much thicker walls than the atria which allows them to perform more work by pumping out blood to the whole body.

**Blood Vessels:** Blood Vessels are tubes which carry blood. Veins are blood vessels which carry blood from the body back to the heart. Arteries are blood vessels which carry blood from the heart to the body. There are also microscopic blood vessels which connect arteries and veins together called capillaries. There are a few main blood vessels which connect to different chambers of the heart. The aorta is the largest artery in our body. The left ventricle pumps blood into the aorta which then carries it to the rest of the body through smaller arteries. The pulmonary trunk is the large artery which the right ventricle pumps into. It splits into pulmonary arteries which take the blood to the lungs. The pulmonary veins take blood from the lungs to the left atrium. All the other veins in our body drain into the inferior vena cava (IVC) or the superior vena cava (SVC). These two large veins then take the blood from the rest of the body into the right atrium.

**Valves:** Valves are fibrous flaps of tissue found between the heart chambers and in the blood vessels. They are rather like gates which prevent blood from flowing in the wrong direction. They are found in a number of places. Valves between the atria and ventricles are known as the right and left atrioventricular valves, otherwise known as the tricuspid and mitral valves respectively. Valves between the ventricles and the great arteries are known as the semilunar valves. The aortic valve is found at the base of the aorta, while the pulmonary valve is found the base of the pulmonary trunk. There are also many valves found in veins throughout the body. However, there are no valves found in any of the other arteries besides the aorta and pulmonary trunk

## Respiratory System

The respiratory system is the organs and other parts of your body involved in breathing, when you exchange oxygen and carbon dioxide. The respiratory system works with the circulatory system to provide this oxygen and to remove the waste products of metabolism. It also helps to regulate pH of the blood.

Respiration is the sequence of events that results in the exchange of oxygen and carbon dioxide between the atmosphere and the body cells. Every 3 to 5 seconds, nerve impulses stimulate the breathing process, or ventilation, which moves air through a series of passages into and out of the lungs. After this, there is an exchange of gases between the lungs and the blood. This is called external respiration. The blood transports the gases to and from the tissue cells. The exchange of gases between the blood and tissue cells is internal respiration. Finally, the cells utilize the oxygen for their specific activities: this is called cellular metabolism, or cellular respiration. Together, these activities constitute respiration.

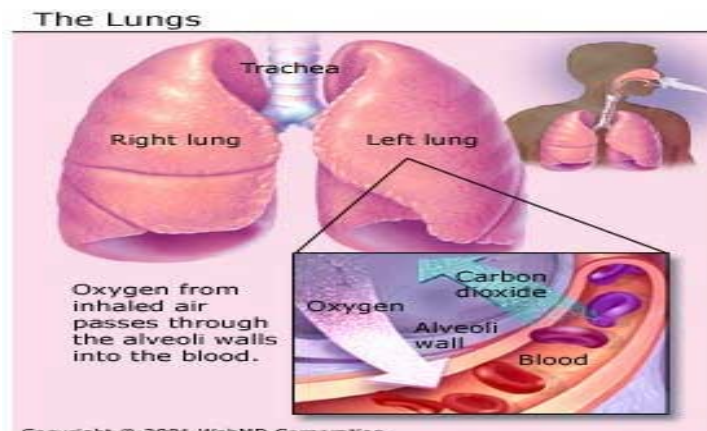

### Parts of the Respiratory System

Respiratory system includes:

- Nose and nasal cavity
  - Sinuses
  - Mouth
  - Throat (pharynx)
  - Voice box (larynx)
  - Windpipe (trachea)
  - Diaphragm
  - Lungs
  - Bronchial tubes/bronchi
  - Bronchioles
  - Air sacs (alveoli)
  - Capillaries
- Breathing starts when you inhale air into your nose or mouth. It travels down the back of your throat and into your windpipe, which is divided into air passages called bronchial tubes.
  - For your lungs to perform their best, these airways need to be open. They should be free from inflammation or swelling and extra mucus.
  - As the bronchial tubes pass through your lungs, they divide into smaller air passages called bronchioles. The bronchioles end in tiny balloon-like air sacs called alveoli. Your body has about 600 million alveoli.

- The alveoli are surrounded by a mesh of tiny blood vessels called capillaries. Here, oxygen from inhaled air passes into your blood.
- After absorbing oxygen, blood goes to your heart. Your heart then pumps it through your body to the cells of your tissues and organs.
- As the cells use the oxygen, they make carbon dioxide that goes into your blood. Your blood then carries the carbon dioxide back to your lungs, where it's removed from your body when you exhale.

### **Inhalation and Exhalation**

- Inhalation and exhalation are how your body brings in oxygen and gets rid of carbon dioxide. The process gets help from a large dome-shaped muscle under your lungs called the diaphragm.
- When you breathe in, your diaphragm pulls downward, creating a vacuum that causes a rush of air into your lungs.
- The opposite happens with exhalation: Your diaphragm relaxes upward, pushing on your lungs, allowing them to deflate.

### **Kidney and blood flow**

- The kidneys are two bean-shaped organs, each about the size of a fist. They are located just below the rib cage, one on each side of your spine.
- Healthy kidneys filter about a half cup of blood every minute, removing wastes and extra water to make urine. The urine flows from the kidneys to the bladder through two thin tubes of muscle called ureters, one on each side of your bladder. Your bladder stores urine. Your kidneys, ureters, and bladder are part of your urinary tract.

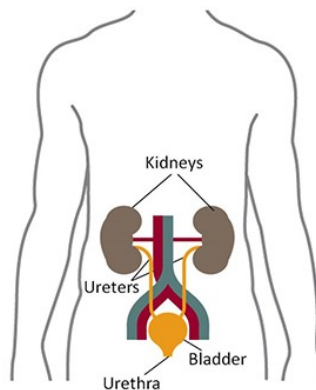

### **Why are the kidneys important?**

Your kidneys remove wastes and extra fluid from your body. Your kidneys also remove acid that is produced by the cells of your body and maintain a healthy balance of water, salts, and minerals—such as sodium, calcium, phosphorus, and potassium—in your blood.

Without this balance, nerves, muscles, and other tissues in your body may not work normally.

### **How does kidneys work?**

Each of your kidneys is made up of about a million filtering units called nephrons. Each nephron includes a filter, called the **glomerulus**, and a **tubule**. The nephrons work through a two-step process: the glomerulus filters your blood, and the tubule returns needed substances to your blood and removes wastes

### **How does blood flow through kidneys?**



Blood flows into your kidney through the renal artery. This large blood vessel branches into smaller and smaller blood vessels until the blood reaches the nephrons. In the nephron, your blood is filtered by the tiny blood vessels of the glomeruli and then flows out of your kidney through the renal vein. Your blood circulates through your kidneys many times a day. In a single day, your kidneys filter about 150 quarts of blood. Most of the water and other substances that filter through your glomeruli are returned to your blood by the tubules. Only 1 to 2 quarts become urine.

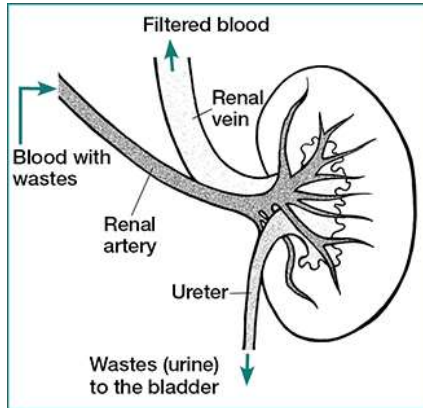

### **Biomechanics of Bone**

The mechanical response of bone to compression, tension, and other complex loads depends on the complex structure of bones. Bones are living tissues with blood supplies, made of a high percentage of water (25% of bone mass), and having considerable deposits of calcium salts and other minerals. The strength of bone depends strongly on its density of mineral deposits and collagen fibers, and is also strongly related to dietary habits and physical activity. The loading of bones in physical activity results in greater osteoblast activity, laying down bone. Immobilization or inactivity will result in dramatic decreases in bone density, stiffness, and mechanical strength. Bones remodel (lay down greater mineral deposits) according to the mechanical stress in that area of bone. This laying down of bone where it is stressed and reabsorption of bone in the absence of stress is called Wolff's Law. Bone remodelling is well illustrated by the formation of bone around the threads of screws in the hip prosthetic in the x-ray.

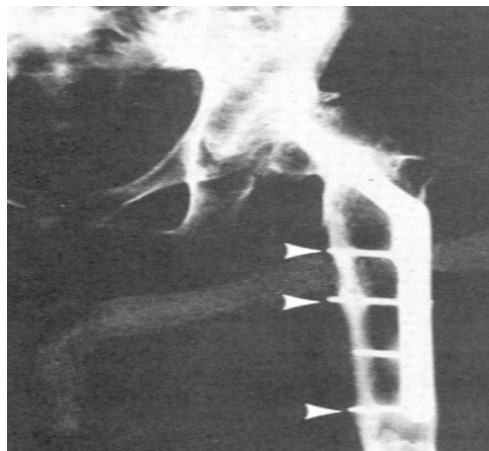

**Fig: X-ray of a fractured femur with a metal plate repair. Note the remodelling of bone around the screws that transfer load to the plate**

The macroscopic structure of bone shows a dense, external layer called cortical (compact) bone and the less-dense internal cancellous (spongy) bone. The mechanical

response of bone is dependent on this “sandwich” construction of cortical and cancellous bone. This design of a strong and stiff material with a weaker and more flexible interior (like fiberglass) results in a composite material that is strong for a given weight.

This is much like a surf board constructed of fiberglass bonded over a foam core. Cortical bone is stiffer (maximum strain about 2%), while cancellous bone is less stiff and can withstand greater strain (7%) before failure. In general, this design results in ultimate strengths of bone of about 200 MPa (29,000 lbs/in<sup>2</sup>) in compression, 125 MPa (18,000 lbs/in<sup>2</sup>) in tension, and 65 MPa (9,500 lbs/in<sup>2</sup>) in shear. This means that an excessive bending load on the femur would most likely cause a fracture to begin on the lateral aspect that is under tensile loading. Using sports rules to protect athletes from lateral blows (like blocking rules in American football) is wise because bone is weakest under shearing loads. It is also important to understand that the ultimate strength of bone depends on nutritional, hormonal, and physical activity factors

**Biomechanics of soft tissues**

**What do we mean by soft tissues?**

A primary group of tissue which binds, supports and protects our human body and structures such as organs is soft connective tissue. It is a wide-ranging biological material in which the cells are separated by extracellular material. Connective tissue may be distinguished from hard (mineralized) tissues such as bones for their high flexibility and their soft mechanical properties.

Examples for soft tissues are tendons, ligaments, blood vessels, skins or articular cartilages

Soft tissues behave anisotropically because of their fibers which tend to have preferred directions. In a microscopic sense they are non-homogeneous materials because of their composition. The tensile response of soft tissue is nonlinear stiffening and tensile strength depends on the strain rate. In contrast to hard tissues, soft tissues may undergo large deformations. Some soft tissues show viscoelastic behaviour (relaxation and/or creep), which has been associated with the shear interaction of collagen with the matrix of proteoglycans [16] (the matrix provides a viscous lubrication between collagen fibrils). In a simplified way we explain here the tensile stress-strain behaviour for skin, an organ consisting mainly of connective tissues, which is representative of the mechanical behaviour of many (collagenous) soft connectives tissues. For the connective tissue parts of the skin the three-dimensional network of fibers appears to have preferred directions parallel to the surface. However, in order to prevent out-of-plane shearing, some fiber orientations also have components out-of-plane. Figure 1 shows a schematic diagram of a typical J-shaped (tensile) stress-strain curve for skin

This form, representative for many soft tissues, differs significantly from stress-strain curves of hard tissues or from other types of (engineering) materials. In addition, Figure 1 shows how the collagen fibers straighten with increasing stress.

Material	Ultimate tensile strength [Mpa]	Ultimate tensile strain [%]	Collagen (% dry weight)	Elastin (% dry weight)
Tendon	50-100	10-15	75-85	< 3
Ligament	50-100	10-15	70-80	10-15
Aorta	0.3-0.8	50-100	25-35	40-50
Skin	1-20	30-70	60-80	5-10
Articular Cartilage	9-40	60-120	40-70	-

**Physiological signals and transducers**

The Human body produces various physiological signals. The accessibility to these signals is important because

- (1) they can be internal (blood pressure)  
 (2) they may emanate from the body (infrared radiation)  
 (3) they may be derived from a tissue sample (blood or tissue biopsy)

All physiological signals can be grouped into the following categories –

- |                               |   |
|-------------------------------|---|
| <b>(1)biopotential</b>        | <b>(5)displacement(velocity,force,acceleration)</b> |
| <b>(2)pressure</b>            | <b>(6)impedance</b>                                 |
| <b>(3)flow</b>                | <b>(7)temperature</b>                               |
| <b>(4)dimensions(imaging)</b> | <b>(8) chemical concentration and composition.</b>  |

### **Sources of Physiological Signals**

Physiological signals are generated by the body during the functioning of various physiological systems. Hence physiological signals hold information which can be extracted from these signals to find out the state of the functioning of these physiological systems. The process of extracting information can be very simple as feeling the pulse to find the state of heart beats and it can be complex which may require analysis of the structure of tissue by a sophisticated machine. Depending on type of energy, the physiological signals can be:

**(a) Bioelectrical signals:** These signals are generated by nerve cells and muscle cells. The source of these signals are cells which undergo change of state from resting potential to action potential under certain conditions. The change of potential in many cells generate an electric field which fluctuates and, in this process, it is to emit bioelectric signal. ECG and EEG are obtained from the bio signals from heart and brain respectively.

**(b) Biomechanical Signals:** These signals are generated by some mechanical function of a physiological system. These signals are related to motion, displacement, pressure and flow of the physiological system. The respiratory physiological system functions with the movement of chest which can be analysed.

**(c) Bioacoustics Signals:** These are created by the physiological systems which are dealing with the flow of blood and air. The flow of the blood in the heart, the opening and closing of chest in respiratory system generate unique acoustic signals.

**(d) Biomagnetic Signals:** Weak magnetic fields are generated by various organs like heart, brain and lungs while functioning. Magneto encephalograph is obtained from the Biomagnetic signals from the brain.

**(e) Biochemical signals:** The information is obtained by chemical measurements from the living tissues or analysis of the samples obtained from the body. The concentrations of various constituents in the blood and the measurement of partial pressure of oxygen and carbon dioxide in respiration are found out by this method.

**(f) Bioimpedance Signals:** The impedance of the skin depends upon the composition of skin, blood distribution and blood volume through the skin. The measurement of impedance helps in finding the state of skin and functioning of various physiological systems. The voltage drop by the tissue impedance is nothing but a bioimpedance signal.

**(g) Bio optical Signals:** These signals are produced by the optical variations by the functioning of the physiological system. The blood oxygenation can be measured by measuring transmitted and reflected light from the blood vessel.

### **Transducer**

Transducer is a device which converts one form of variable or energy into another form of variable or energy. Generally, transducer is required to convert physiological variables into electrical signals

which are easier to be processed. The relationship between input and output variable can be linear, logarithmic or square. The transducer can be active or passive depending upon conversion of non-electrical variable into electrical signal. The active transducer directly converts input variable into electrical signals while passive transducer modifies either excitation voltages or modulates the carrier signals. The passive transducers are externally powered while active transducers are self-generating

### **Transducers**

- Transducer is a device which converts one form of energy into electrical form. Because of the advantages of electric and electronic method of measurement.
- In Biomedical Instrumentation the main concern is conversion of Bioelectric signal to electric signal. Here transducer is a component which has a nonelectrical variable as its input and an electrical signal as its output.
- To conduct its function properly, one (or more) parameters of the electrical output signal in the form of voltages, current frequency or pulse width must be a non-ambiguous function of the nonelectrical variables at the input.
- As long as the transduction function is non-ambiguous it is possible to determine the magnitude of the input variable from the electrical output signal at least in principle. Certain other variables may interface with the transduction process such as hysteresis error, frequency response and base line drift.
- There are two different principles used to convert nonelectrical variables into electrical signals. One of these is energy conversion transducers based on this principle are called Active transducers. The other principle involves control of an excitation voltage or modulation of a carrier signal. Transducers based on this principle are called passive transducers. The two transducer types will be described separately in the following sections. A physical principle can be employed for converting nonelectrical activity in active transducers. But not all principles are of practical importance in the design of actual transducers, specially for biomedical applications.

#### **Active Transducer**

A physical principle can be employed for converting nonelectrical activity in active transducers. But, not all principles are of practical importance in the design of actual transducers, specially for biomedical applications. In active transducers, in some cases the same transduction principle used to convert from a nonelectrical form of energy can also be used in reverse direction to convert electrical energy to non-electrical energy.

#### **Passive Transducer**

A d.c excitation voltage or an ac carrier signal utilize the principle of controlling passive transducers. The transducer consists of a usually passive circuit element which changes its value as a function of the physical variable to be measured. The transducer is a part of circuit element, normally an arrangement like Wheatstone bridge, which is powered by an ac or d.c excitation, signal. The voltage at the output reflects the physical variable. There are only three passive circuit elements which can be utilized as passive transducers namely: resistors, capacitors and inductors. It may also be noted. That active components like transistors can also occasionally be used. The active and passive have different meaning in components and transducers. Passive transducers cannot be operated. in the reverse direction unlike active transducers.

#### **Selection criteria for Transducer**

- **Operating range:** The range of transducer should be appropriate for measurement to get a good resolution.
- **Operating Principle:** The transducers are selected on the basis of operating principle it may be resistive, inductive, capacitive, optical etc.
- **Accuracy:** The accuracy should be as high as possible or as per the measurement.

- **Range:** The transducer can give good result within its specified range, so select transducer as per the operating range.
- **Sensitivity:** The transducer should be more sensitive to produce the output or sensitivity should be as per requirement.
- **Environmental compatibility:** The transducer should maintain input and output characteristic for the selected environmental condition.
- **Loading effect:** The transducer's input impedance should be high and output impedance should be low to avoid loading effect.
- **Errors:** The error produced by the transducer should be low as possible.

### **Piezo-electric**

The Piezoelectric transducer is an **electroacoustic transducer** use for conversion of pressure or mechanical stress into an alternating electrical force. It is used for measuring the physical quantity like force, pressure, stress, etc., which is directly not possible to measure.

The piezo transducer converts the physical quantity into an electrical voltage which is easily measured by analogue and digital meter.

The piezoelectric transducer uses the piezoelectric material which has a special property, i.e. the material induces voltage when the pressure or stress applied to it. The material which shows such property is known as the electro-resistive element.

The Quartz is the examples of the natural piezoelectric crystals.

### **Piezoelectric Effect**

The EMF develops because of the displacement of the charges. The effect is changeable, i.e. if the varying potential applies to a piezoelectric transducer, it will change the dimension of the material or deform it. This effect is known as the piezoelectric effect.

The pressure is applied to the crystals with the help of the force summing devices for examples the stress is applied through mechanical pressure gauges and pressure sensors, etc. The deformation induces the EMF which determines the value of applied pressure.

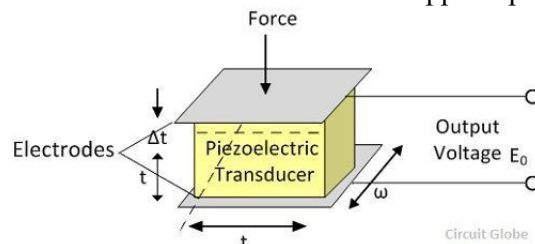

The voltage sensitivity of the crystals is expressed by the ratio of the electric field intensity and pressure.

When the mechanical deformation occurs in the crystals, it generates charges. And this charge develops the voltages across the electrodes.

The Piezoelectric crystal is direction sensitive. The polarity of the voltage depends on the direction of the force which is either tensile or compressive. The magnitude and the polarity of the charges depend on the magnitude and the direction of the applied force.

### **Properties of Piezo Electric-Crystal**

The following are the properties of the Piezoelectric Crystals.

1. The piezoelectric material has high stability.
2. It is available in various shapes and sizes.
3. The piezoelectric material has output insensitive to temperature and humidity.

## Ultrasonic transducers

- Sound that is generated above the level of human hearing range is called ultrasound. Although ultrasound typically starts at 20 MHz, most ultrasonic transducers start at 200 KHz. Ultrasound, which is similar in nature to audible sound, has far shorter wavelengths and is far more suitable to detect small flaws. These shorter wavelengths are what make ultrasound and ultrasonic transducers extremely useful for non-destructive testing and measurement of materials.
- An ultrasonic transducer itself is a device that is capable of generating and receiving ultrasonic vibrations. An ultrasonic transducer is made up of an active element, a backing, and wear plate. The active element is a piezoelectric or single crystal material which converts electrical energy to ultrasonic energy. It will also then receive back ultrasonic energy and converts it to electrical energy. The electrical energy pulse is generated from an instrument such as a flaw detector.
- The backing is most commonly a highly attenuative and very dense material and is used to control the vibration of the transducer crystal by absorbing the energy that radiates from the back face of the piezoelectric element. When the acoustic impedance of the backing material matches that of the piezoelectric crystal, the result is a highly damped transducer with excellent resolution. By varying the backing material in order to vary the difference in impedance between the backing and the piezoelectric crystal, a transducer will suffer somewhat and resolution may be much higher in signal amplitude or sensitivity.
- The main purpose of the wear plate is simply to protect the piezoelectric transducer element from the environment. Wear plates are selected to generally protect against wear and corrosion. In an immersion-type transducer, the wear plate also serves as an acoustic transformer between the piezoelectric transducer element and water, wedge or delay line.

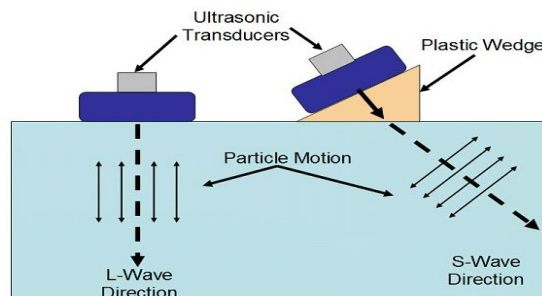

## **Applications of Ultrasonic Transducer**

1. Ranging and Navigating
2. Diagnosis
3. Therapy and surgery
4. Doppler Effect
5. Medical imaging techniques

## Temperature measurement

A Thermometer is a device that measures temperature or temperature gradient.

Thermometers can be divided into two groups according to the level of knowledge about the physical basis of the underlying thermodynamic laws and quantities.

1. Primary thermometers; the measured property of matter is known so well that temperature can be calculated without any unknown quantities. Examples of these are thermometers based on the equation of state of a gas, on the velocity of sound in a gas, on the thermal noise, voltage or current of an electrical resistor, and on the angular anisotropy of gamma ray emission of certain radioactive nuclei in a magnetic field.



2. Secondary thermometers are most widely used because of their convenience. Also, they are often much more sensitive than primary ones. For secondary thermometers knowledge of the measured property is not sufficient to allow direct calculation of temperature. They have to be calibrated against a primary thermometer at least at one temperature or at a number of fixed temperatures. Such fixed points, for example, triple points and superconducting transitions, occur reproducibly at the same temperature.

### Thermocouple

A **Thermocouple** is a sensor for measuring temperature. This sensor consists of two dissimilar metal wires, joined at one end, and connected to a thermocouple thermometer or other thermocouple-capable device at the other end. When properly configured, thermocouples can provide temperature measurements over wide range of temperatures.

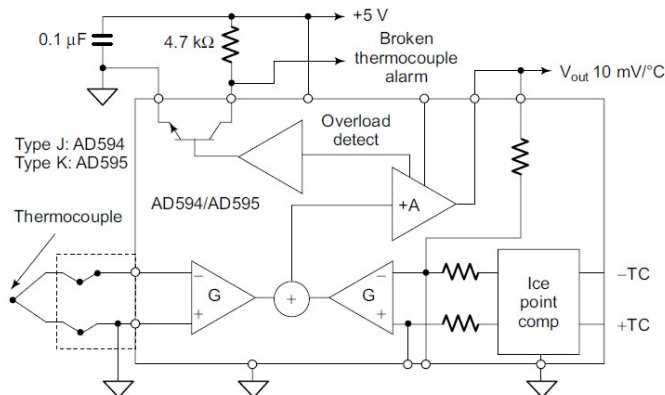
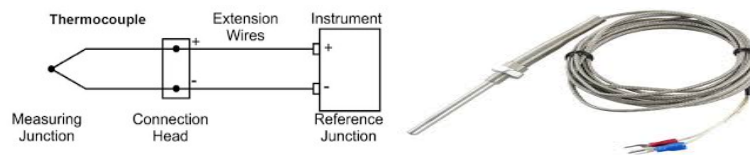

**Thermocouple amplifiers with cold junction compensation**

### Thermistors

Thermistors are the oxides of certain metals like manganese, cobalt and nickel which have largenegative temperature coefficient of resistance, i.e. resistance of the thermistor shows a fall withincrease in temperature

Thermistors when used for measuring temperature have many advantages over thermocouplesand resistance thermometers.

The large change in resistance with temperature means that a comparatively simplebridge circuit is sufficient.

### Infrared thermometers

Measure temperature using blackbody radiation (generally infrared) emitted from objects. They are sometimes called laser thermometers if a laser is used to help aim the thermometer, or non-contact thermometers to describe the device's ability to measure temperature from a distance. By knowing the



amount of infrared energy emitted by the object and its emissivity, the object's temperature can be determined. The most basic design consists of a lens to focus the infrared energy on to a detector, which converts the energy to an electrical signal that can be displayed in units of temperature after being compensated for ambient temperature variation. This configuration facilitates temperature measurement from a distance without contact with the object to be measured

### Liquid crystal thermometer

A **liquid crystal** thermometer or plastic strip thermometer is a type of thermometer that contains heat-sensitive (thermochromic) liquid crystals in a plastic strip that change colour to indicate different temperatures. Liquid crystals possess the mechanical properties of a liquid, but have the optical properties of a single crystal. Temperature changes can affect the colour of a liquid crystal, which makes them useful for temperature measurement.

### Fiber-Optic Temperature Sensors

- The details of a GaAs semiconductor temperature probe. A small prism-shaped sample of single-crystal undoped GaAs is epoxied at the end of two side-by-side optical fibers. The Sensors and fibers can be quite small, comparable with biological implantation after being sheathed. One fiber transmits light from light -emitting diode source to the sensor, where it is passed the GaAs and collected by the others fiber for detection in the readout for the instrument.
- Some of the optical power travelling through the semiconductor is absorbed, by the process of raising valence-band electrons, across the forbidden energy gap into the conduction band. Because the forbidden energy gap is a sensitive function of a materials temperature, the amount of the power absorbed increases with temperature.
- This non-metallic probe is particularly suited for temperature measurement in the strong electromagnetic heating fields used in heating tissue for cancer therapy or in-patient rewarming.

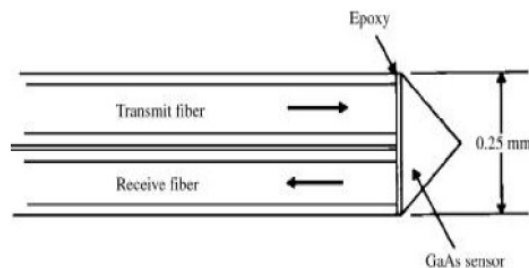

**Figure 2.19** Details of the fiber-sensor arrangement for the GaAs semiconductor temperature probe.

- **Fiber optics** are essentially light pipes. The group of sensors known as fiber optic thermometers generally refer to those devices measuring higher temperatures wherein blackbody radiation physics are utilized. The Fiber Optic Temperature Sensors use either WLPI or GaAs technology and can be used in a wide range of applications ranging from cryogenic temperature to high temperature up to 350 degrees
- Lower temperature targets--say from  $-100^{\circ}\text{C}$  to  $400^{\circ}\text{C}$ --can be measured by activating various sensing materials such as phosphors, semiconductors or liquid crystals with fiber optic links offering the environmental and remoteness advantages

### Fiber Bragg Grating

This type of sensors has been widely applied in the measurement of different parameters, such as physical, chemical, clinical, biomedical and electrical parameters in the energy, aerospace and civil fields. They are simple, intrinsic sensing elements, which can be photo-inscribed into silica fiber and offer all the advantages associated with fiber optic sensors. Typically, a FBG sensor can be seen as a selective photo-induced modulation of the optical fiber core refractive index. The FBG resonant



wavelength (Bragg wavelength),  $\lambda_B$ , is related to the effective refractive index of the core mode ( $n_{eff}$ ) and the grating period ( $\Lambda$ )

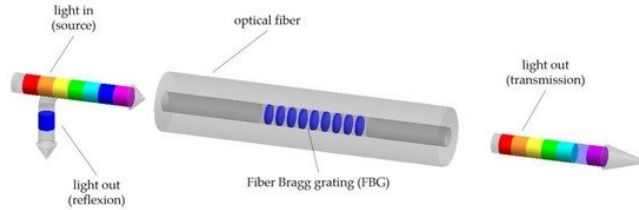

When the grating is illuminated by a broadband optical source, the reflected spectrum presents a sharp peak, which is caused by interference of light with the planes of the grating. Any perturbation on the grating (e.g., external strain or temperature variation) results in a shift in the Bragg wavelength, which can be detected either in the reflected or transmitted spectra.

### Biomedical Optical Fiber Temperature Sensors

Fiber optic fluorescent techniques have been proposed. The fluoroptic technology uses fluorescent materials, such as rare-earth phosphors or gallium arsenide (GaAs), and an adequate light source to excite them. Temperature can be determined by measuring fluorescence emission decay times in the fluoroptic probes

Solid state materials can also be used for fluorescence thermometry and some schemes have been presented for biomedical purposes, using the ruby and the trivalent-chromium ion doped material

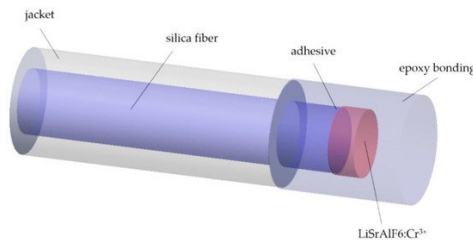

### The probe of fiber temperature

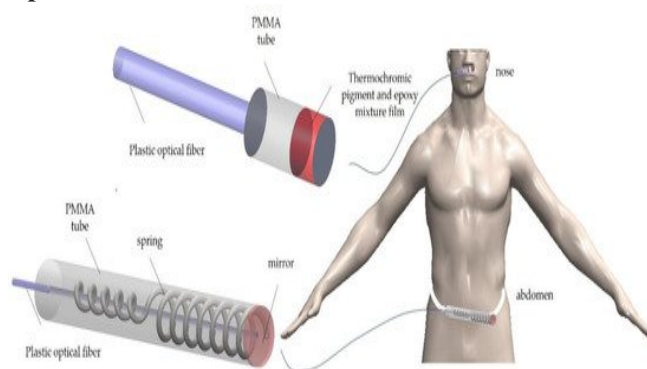

**Schematic drawing of the structures of the nasal-cavity and abdomen-attached fiber-optic sensors**

### Advantages of Using Fiber Optics for Temperature Measurements

Whether used for communications or infrared temperature measurement, fiber optics offer some inherent advantages for measurements in industrial and/or harsh environments:

- Unaffected by electromagnetic interference (EMI) from large motors, transformers, welders and the like;

- Unaffected by radio frequency interference (RFI) from wireless communications and lightning activity;
- Can be positioned in hard-to-reach or view places;
- Can be focused to measure small or precise locations;
- Does not or will not carry electrical current (ideal for explosive hazard locations);
- Fiber cables can be run in existing conduit, cable trays or be strapped onto beams, pipes or conduit (easily installed for expansions or retrofits);
- Certain cables can handle ambient temperatures to over 300°C--higher with air or water purging

## POST MCQ

1. The minimum input of physical parameter that will create a detectable out change is called \_\_\_\_\_
  - a) Threshold
  - b) Sensitivity
  - c) Span
  - d) Precision
 Answer: b
2. Ability of the sensor to repeat a measurement when put back in the same environment is called \_\_\_\_\_
  - a) Conformance
  - b) Saturation
  - c) Repeatability
  - d) Threshold
 Answer: c
3. Closeness of a calibration curve to a specified curve for an inherently non linear transducer is called \_\_\_\_\_
  - a) Conformance
  - b) Linearity
  - c) Saturation
  - d) Hysteresis
 Answer: a
4. The range between the maximum and minimum values is applied to a parameter which can be measured is \_\_\_\_\_
  - a) Repeatability
  - b) Span
  - c) Input range
  - d) Output range
 Answer: b
5. Sudden involuntary drop in body core temperature below 35°C (95°F) is called \_\_\_\_\_
  - a) Accidental hyperthermia
  - b) Accidental misothermia
  - c) Accidental exothermia

d) Accidental hypothermia

Answer: d

## UNIT - II

### NON-ELECTRICAL PARAMETERS MEASUREMENT AND DIAGNOSTIC PROCEDURES

#### AIM

To understand the Physiology of the heart, lung, blood circulation and respiration including different transducers used.

#### PRE MCQ:

1. Who provides valuable information about a wide range of cardiac disorders?

- a) VCG
- b) ECG
- c) PCG
- d) EEG

Answer: b

2. For rehabilitation engineering perspective a task that is specific to a single sense or movement pattern is called \_\_\_\_\_

- a) Functional Limitation
- b) Societal Limitation
- c) Modality-Specific
- d) Pathophysiology

Answer: c

3. Aesthetics of appearance is called \_\_\_\_\_

- a) Orthosis
- b) Cosmesis
- c) Lymphosis
- d) Homeostasis

Answer: b

4. Which of the following is not a soft tissue?

- a) Ligament
- b) Bone
- c) Tendons
- d) Skin

Answer: b

5. Which of the following instrument is used for recording the electrical activity of the muscles?

- a) ECG
- b) EMG
- c) PCG

d) EEG  
Answer: b

## **THEORY:**

### **Measurement of Blood Pressure**

The heart supplies the organs and tissues of the body with blood. With every beat, it pumps blood into the large blood vessels of the circulatory system. As the blood moves around the body, it puts pressure on the walls of the vessels. Blood pressure readings are made up of two values:

- **Systolic blood pressure** is the pressure when the heart beats – while the heart muscle is contracting (squeezing) and pumping oxygen-rich blood into the blood vessels.
- **Diastolic blood pressure** is the pressure on the blood vessels when the heart muscle relaxes. The diastolic pressure is always lower than the systolic pressure.

Blood pressure is measured in units of millimetres of mercury (mmHg). The readings are always given in pairs, with the upper (systolic) value first, and followed by the lower (diastolic) value.

So, someone who has a reading of 132/88 mmHg (often spoken “132 over 88”) has a

- **Systolic blood pressure** of 132 mmHg.
- **Diastolic blood pressure** of 88 mmHg.
- **Hypertension** – high blood pressure: consistently >140/90mmHg
- **Hypotension** – low blood pressure: typically, a systolic reading of <90mmHg

### **Blood Pressure can be measured in two ways:**

- Manually, using the auscultatory method – this involves listening to arterial sounds.
- Automatically, using the oscillometer method – this detects variations in pressure oscillations due to arterial wall movement.

Both methods use a measuring device attached to an inflatable cuff that is placed around the patient’s upper arm, inflated to occlude the artery under the cuff, and then released in a controlled manner.

BP is a variable haemodynamic phenomenon, and can be influenced by a range of factors

### **Factors that can cause a variation in blood pressure**

- Emotional state
- Temperature
- Respiration
- Bladder distension
- Sudden change in posture
- Tobacco use
- Pain
- Exercise

### **Manual Auscultatory measurement**

Manual BP measurement devices require the user to inflate the upper-arm cuff to occlude the brachial artery, then listen to the Korotkoff sounds through a stethoscope while the cuff is slowly deflated. When the cuff is slowly deflated, five different sound phases can be heard:

- Phase I – a thud;
- Phase II – a blowing or swishing noise;
- Auscultatory gap – in some patients, the sounds disappear for a short period;
- Phase III – a softer thud than in phase I;
- Phase IV – a disappearing blowing noise;
- Phase V – silence: all sounds disappear.

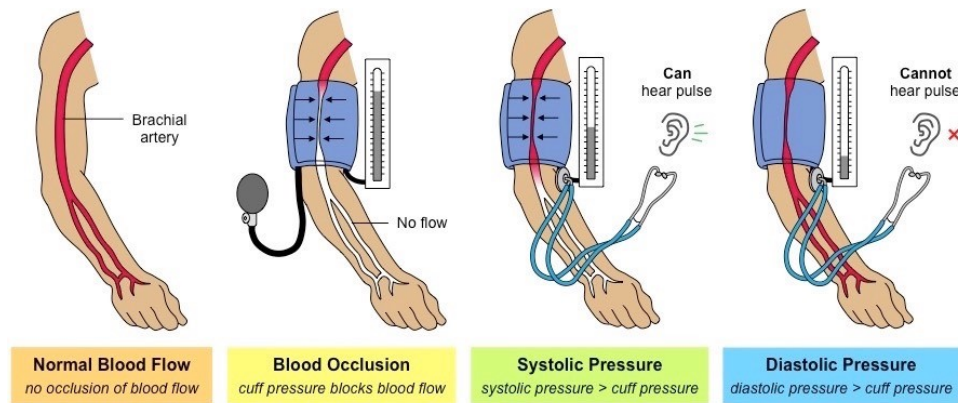

### Devices that are generally used for manual BP measurement include:

- Aneroid sphygmomanometer – this replaces the mercury manometer with an aneroid (liquid-free) gauge that registers pressure using a bellows and lever system (O’Brien, 2015), and requires use of a stethoscope;
- Electronic sphygmomanometer – this battery-powered device replaces the mercury manometer with a pressure sensor and electronic display. The display may be numerical, or a circular or linear bar graph. No stethoscope is needed.

### Automated measurement

#### Automated electronic BP devices

Most automated BP measurement devices in current clinical practice use the oscillometric method. Each arterial pulse wave results in a small rise and fall in the volume of the limb which, in turn, causes an increase then a decrease in the pressure within the encircling cuff. The oscillometric method relies on detection of variations in pressure oscillations due to arterial wall movement beneath an occluding cuff to calculate the systolic and diastolic BP readings

### Cardiac Output

Cardiac output (CO) is the amount of blood pumped by the heart minute and is the mechanism whereby blood flows around the body, especially providing blood flow to the brain and other vital organs. The body’s demand for oxygen changes, such as during exercise, and the cardiac output is altered by modulating both heart rate (HR) and stroke volume (SV). As a result, the regulation of cardiac output is subject to a complex mechanism involving the autonomic nervous system, endocrine, and paracrine signalling pathways

Because every tissue in the body relies on the heart pumping blood for nourishment, any cardiovascular dysfunction has the potential to result in significant morbidity and mortality. The degree of functional impairment can be assessed by a variety of methods that guides diagnosis, prognosis, and treatment

Cardiac output, expressed in liters/minute, is the amount of blood the heart pumps in 1 minute. Cardiac output is logically equal to the product of the stroke volume and the number of beats per minute (heart rate).

#### Normal Output

It’s different for different people, depending on their size. Usually, an adult heart pumps about 5 liters of blood per minute at rest. But when you run or exercise, your heart may pump 3-4 times that much to make sure your body gets enough oxygen and fuel.

#### How It’s Measured

Your cardiac output is your heart beats per minute multiplied by the amount of blood pumped with each beat.

Your doctor can measure it in lots of ways.

**Pulmonary artery catheter.** Your doctor inserts this device into the artery that sends blood to the lungs to pick up oxygen.

**Echocardiogram.** This uses sound waves to make an image of your heart and blood flow through your heart.

**Arterial pulse waveform analysis.** These calculate the cardiac output from shock waves created by blood flow.

### **Low Output**

If your heart doesn't pump enough blood to supply your body and tissues, it could signal heart failure. Low output also could happen after you've lost too much blood, had a severe infection called sepsis, or had severe heart damage.

### **High Output**

Sometimes, sepsis, your body's response to blood infections that can lead to a dangerous drop in blood pressure and organ failure, can cause high cardiac output.

High output also can happen when your body lacks enough oxygen-carrying red blood cells, a condition called anemia. That makes your heart pump more blood faster. Another common cause is hyperthyroidism, which is when your thyroid gland makes more thyroid hormones than needed.

### **Heart Rate**

Your **heart rate**, or pulse, is the number of times your heart beats in 1 minute. Heart rates vary from person to person. It's lower when you're at rest and higher when you exercise.

As you age, changes in the rate and regularity of your pulse can change and may signify a heart condition or other condition that needs to be addressed

The best places to find your pulse are the:

- wrists
- inside of your elbow
- side of your neck
- top of the foot
- To get the most accurate reading, put your finger over your pulse and count the number of beats in 60 seconds.
- Your **resting heart rate** is the heart pumping the lowest amount of blood you need because you're not exercising. If you're sitting or lying and you're calm, relaxed and aren't ill, your heart rate is normally between 60 (beats per minute) and 100 (beats per minute).
- But a heart rate lower than 60 doesn't necessarily signal a medical problem. It could be the result of taking a drug such as a beta blocker. A lower heart rate is also common for people who get a lot of physical activity or are very athletic. Active people often have a lower resting heart rate (as low as 40) because their heart muscle is in better condition and doesn't need to work as hard to maintain a steady beat. A low or moderate amount of physical activity doesn't usually change the resting pulse much.

### **How Other Factors Affect Heart Rate**

- **Air temperature:** When temperatures (and the humidity) soar, the heart pumps a little more blood, so your pulse rate may increase, but usually no more than five to 10 beats a minute.
- **Body position:** Resting, sitting or standing, your pulse is usually the same. Sometimes as you stand for the first 15 to 20 seconds, your pulse may go up a little bit, but after a couple of minutes it should settle down.
- **Emotions:** If you're stressed, anxious or "extraordinarily happy or sad" your emotions can raise your pulse.
- **Body size:** Body size usually doesn't change pulse. If you're very obese, you might see a higher resting pulse than normal, but usually not more than 100.
- **Medication use:** Meds that block your adrenaline (beta blockers) tend to slow your pulse, while too much thyroid medication or too high of a dosage will raise it.

### **Heart Sound**

When a stethoscope is placed on the chest over different regions of the heart, there are four basic heart sounds that can be heard (listening to heart sounds is called cardiac auscultation). The sounds waves responsible for heart sounds (including abnormal sounds such as murmurs) are generated by vibrations induced by valve closure, abnormal valve opening, vibrations in the ventricular chambers, tensing of the chordae tendineae, and by turbulent or abnormal blood flow across valves or between cardiac chambers

The common mechanisms by which heart sounds are generated include

- (1) opening or closure of the heart valves
- (2) flow of blood through the valve orifice
- (3) flow of blood into the ventricular chambers
- (4) rubbing of cardiac surfaces.

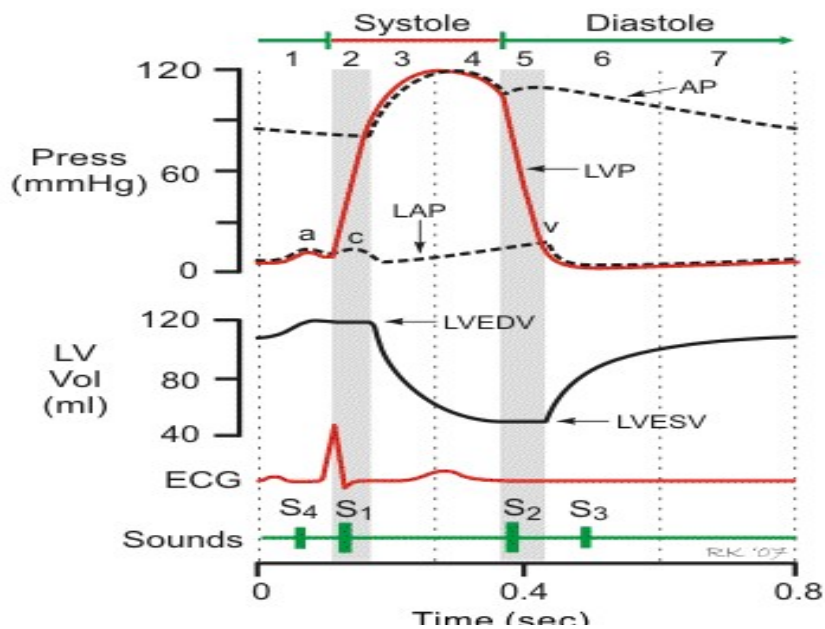

The most fundamental heart sounds are the first and second sounds, usually abbreviated as  $S_1$  and  $S_2$ .  $S_1$  is caused by closure of the mitral and tricuspid valves at the beginning of isovolumetric ventricular contraction.  $S_1$  is normally slightly split ( $\sim 0.04$  sec) because mitral valve closure precedes tricuspid valve closure; however, this very short time interval cannot normally be heard with a stethoscope so only a single sound is perceived.  $S_2$  is caused by closure of the aortic and pulmonic valves at the beginning of isovolumetric ventricular relaxation.  $S_2$  is physiologically split because aortic valve closure normally precedes pulmonic valve closure. This splitting is not of fixed duration.  $S_2$  splitting changes depending on respiration, body posture and certain pathological conditions.

The third heart sound ( $S_3$ ), when audible, occurs early in ventricular filling, and may represent tensing of the chordae tendineae and the atrioventricular ring, which is the connective tissue supporting the AV valve leaflets. This sound is normal in children, but when heard in adults it is often associated with ventricular dilation as occurs in systolic ventricular failure.

The fourth heart sound ( $S_4$ ), when audible, is caused by vibration of the ventricular wall during atrial contraction. This sound is usually associated with a stiffened ventricle (low ventricular compliance), and therefore is heard in patients with ventricular hypertrophy, myocardial ischemia, or in older adults.

Heart Sound	Occurs during:	Associated with:
$S_1$	Isovolumetric contraction	Closure of mitral and tricuspid valves
$S_2$	Isovolumetric relaxation	Closure of aortic and pulmonic valves
$S_3$	Early ventricular filling	Normal in children; in adults, associated with ventricular dilation (e.g. ventricular systolic failure)
$S_4$	Atrial contraction	Associated with stiff, low compliant ventricle (e.g., ventricular hypertrophy; ischemic ventricle)

## Pulmonary function measurements

Pulmonary function tests (PFTs) are non-invasive tests that show how well the lungs are working.

The tests measure lung volume, capacity, rates of flow, and gas exchange. This information can help your healthcare provider diagnose and decide the treatment of certain lung disorders. How the Test is performed.

Three basic types of measurements are made in the pulmonary clinic: ventilation, distribution and diffusion.

- Ventilation deals with the measurement of the body as an air pump, determining its ability to move volumes of air and the speed with which it moves the air.
- Distribution measurements provide an indication of where gas flows in the lungs and whether or not disease has closed some sections to air flow.
- Diffusion measurements test the lung's ability to exchange gas with the circulatory system.

The most widely performed measurement is **ventilation**. This is performed using devices called spirometers that measure volume displacement and the amount of gas moved in a specific time. Usually this requires the patient to take a deep breath and then exhale as rapidly and completely as possible. Called the forced vital capacity, this gives an indication of how much air can be moved by the lungs and how freely this air flows.

**Distribution measurements** quantify degrees of lung obstructions and also determine the residual volume, which is the amount of air that cannot be removed from the lungs by the patient's effort. The residual volume is measured indirectly, such as with the nitrogen washout procedure.

**Diffusion measurements** identify the rate at which gas is exchanged with the blood stream. This is difficult to do with oxygen since it requires a sample of pulmonary capillary blood, so it is usually done by measuring the diminishment of a small quantity of carbon monoxide mixed with the inhaled air.

Pulmonary function analysers provide the means for automated clinical procedures and analysis techniques for carrying out a complete evaluation of the lung function or the respiratory process. The respiratory activity ensures supply of oxygen to and removal of carbon dioxide from the tissues. These gases are carried in the blood—oxygen from the lungs to the tissues and carbon dioxide from the tissues to the lungs.

Air or tidal volume is about 0.5, only part of this volume takes part actually in oxygenating the blood, because no exchange of gases between air and blood takes place in the mouth, trachea and bronchi. The air filling these parts is called 'Dead Space' air.

The ultimate function of the lungs is to exchange gas with the environment, measurement of the arterial blood gases would be sufficient to assess lung function.

The ability of the pulmonary system to move air and exchange oxygen and carbon dioxide is affected by the various components of the air passages, the diaphragm, the rib cage and its associated muscles and by the characteristics of the lung tissue itself.

The pulmonary function can be assessed by means of two major classes of tests. These are:

- (i) Evaluation of the mechanical aspects of pulmonary function, which affects the bulk transport into and out of the lungs.
- (ii) Evaluation of gas exchange or diffusion at the alveoli.

## **Respiratory Volumes**

**Tidal Volume (TV):** The volume of gas inspired or expired (exchanged with each breath) during normal quiet breathing, is known as tidal volume.

**Minute Volume (MV):** The volume of gas exchanged per minute during quiet breathing. It is equal to the tidal volume multiplied by the breathing rate.

**Alveolar Ventilation (AV):** The volume of fresh air entering the alveoli with each breath

$$\text{Alveolar Ventilation} = (\text{Breathing rate}) \times (\text{Tidal volume} - \text{Dead space}).$$



**Inspiratory Reserve Volume (IRV):** The volume of gas, which can be inspired from a normal end-tidal volume.

$$IRV = VC - (TV + FRC)$$

**Expiratory Reserve Volume (ERV):** The volume of gas remaining after a normal expiration less the volume remaining after a forced expiration.

$$ERV = FRC - RV$$

**Residual Volume (RV):** The volume of gas remaining in the lungs after a forced expiration

### Respiratory Capacities

**Functional Residual Capacity (FRC):** The volume of gas remaining in the lungs after normal expiration.

**Total Lung Capacity (TLC):** The volume of gas in the lungs at the point of maximal inspiration.

$$TLC = VC + RV$$

**Vital Capacity (VC):** The greatest volume of gas that can be inspired by voluntary effort after maximum expiration, irrespective of time.

**Inspiratory Capacity (IC):** The maximum volume that can be inspired from the resting end expiratory position.

**Dead Space:** Dead Space is the functional volume of the lung that does not participate in gas exchange.

Pulmonary function tests are performed for the assessment of the lung's ability to act as a mechanical pump for air and the ability of the air to flow with minimum impedance through the conducting airways. These tests are classified into two groups: single-breath tests and multiple-breath tests.

There are three types of tests under the single-breath category are:

- Tests that measure expired volume only.
- Tests that measure expired volume in a unit time.
- Tests that measure expired volume/time

In the class of multiple-breath test measurements is the Maximal Voluntary Ventilation (MVV) which is defined as the maximum amount of air that can be moved in a given time period

### Normal Results

Normal values are based on your age, height, ethnicity, and sex. A value is usually considered abnormal if it is approximately less than 80% of your predicted value.

Different measurements that may be found on your report after pulmonary function tests include:

- Diffusion capacity to carbon monoxide (DLCO)
- Expiratory reserve volume (ERV)
- Forced vital capacity (FVC)
- Forced expiratory volume in 1 second (FEV1)
- Forced expiratory flow 25% to 75% (FEF25-75)
- Functional residual capacity (FRC)
- Maximum voluntary ventilation (MVV)
- Residual volume (RV)
- Peak expiratory flow (PEF)
- Slow vital capacity (SVC)
- Total lung capacity (TLC)

### What Abnormal Results Mean

Abnormal results usually mean that you may have chest or lung disease.

Some lung diseases (such as emphysema, asthma, chronic bronchitis, and infections) can make the lungs contain too much air and take longer to empty.

Other lung diseases make the lungs scarred and smaller so that they contain too little air and are poor at transferring oxygen into the blood. Examples of these types of illnesses include:

- Extreme overweight

- Pulmonary fibrosis (scarring or thickening of the lung tissue)
- Sarcoidosis and scleroderma

Muscular weakness can also cause abnormal test results, even if the lungs are normal, that is, similar to the diseases that cause smaller lungs.

### **Risks**

There is a small risk of collapsed lung (pneumothorax) in people with a certain type of lung disease. The test should not be given to a person who has experienced a recent heart attack, has certain other types of heart disease, or has had a recent collapsed lung.

### **Spirometer**

Spirometry is a standard test doctors use to measure how well your lungs are functioning. The test works by measuring airflow into and out of your lungs.

To take a spirometry test, you sit and breathe into a small machine called a spirometer. This medical device records the amount of air you breathe in and out and the speed of your breath.

Spirometry tests are used to diagnose these conditions:

- COPD
- asthma
- restrictive lung disease (such as interstitial pulmonary fibrosis)
- other disorders affecting lung function

They also allow your doctor to monitor chronic lung conditions to check that your current treatment is improving your breathing.

Spirometry is often done as part of a group of tests known as pulmonary function tests.

It can help distinguish between diseases with similar symptoms and determine whether the condition is obstructive (in which exhalation is impaired) and/or restrictive (in which inhalation is impaired).

Spirometry is rarely used alone to diagnose a lung condition. It is typically combined with other findings, such as a physical exam, medical history review, and imaging tests, to reach a diagnosis.

Spirometry is also useful for evaluating disease progression (namely, whether it is getting better, worse, or staying the same). This can help determine if a treatment is working or needs to be modified.

Spirometry may also be used before lung cancer surgery to predict how well a patient will tolerate the operation and manage once a portion or lobe of a lung is removed.

### **Spirometry side effects**

Few complications can occur during or after a spirometry test. You may feel a bit dizzy or have some shortness of breath immediately after performing the test. In very rare cases, the test may trigger severe breathing problems.

The test requires some exertion, so it isn't recommended if you recently had a heart condition or have other heart problems.

### **Interpreting Results**

Since the results of your test are immediately available, your doctor will likely be able to review them with you at your appointment.

Spirometry provides two important measurements of lung function:

- Forced vital capacity (FVC), a measure of how much air you can blow out of your lungs with a complete breath
- Forced expiratory volume (FEV1), the amount of air you can blow out of your lungs in one second

When the doctor is satisfied that the test results are valid, the information will be used to determine if lung function is normal or abnormal. Only the greatest FEV1 and FVC values will be used for this. All others will be ignored.

Abnormal results indicate one of three possible breathing patterns:

- Obstructive
- Restrictive

- A combination of both

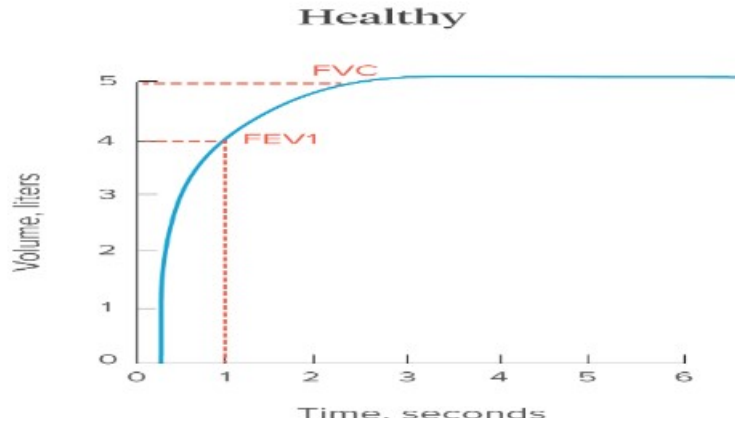

### **Photoplethysmography (PPG)**

Photoplethysmography (PPG) is a simple optical technique used to detect volumetric changes in blood in peripheral circulation. It is a low cost and non-invasive method that makes measurements at the surface of the skin. The technique provides valuable information related to our cardiovascular system.

#### **Principle of PPG**

PPG makes use of low-intensity infrared (IR) light. When light travels through biological tissues it is absorbed by bones, skin pigments and both venous and arterial blood. Since light is more strongly absorbed by blood than the surrounding tissues, the changes in blood flow can be detected by PPG sensors as changes in the intensity of light. The voltage signal from PPG is proportional to the quantity of blood flowing through the blood vessels. Even small changes in blood volume can be detected using this method, though it cannot be used to quantify the amount of blood.

A PPG signal has several components including volumetric changes in arterial blood which is associated with cardiac activity, variations in venous blood volume which modulates the PPG signal, a DC component showing the tissues' optical property and subtle energy changes in the body. Some major factors affecting the recordings from the PPG are site of measurement and the contact force between the site and the sensor. Blood flow variations mostly occur in the arteries and not in the veins.

#### **The PPG Waveform**

PPG shows the blood flow changes as a waveform with the help of a bar or a graph. The waveform has an alternating current (AC) component and a direct current (DC) component.

The AC component corresponds to variations in blood volume in synchronization with the heartbeat. The DC component arises from the optical signals reflected or transmitted by the tissues and is determined by the tissue structure as well as venous and arterial blood volumes.

The DC component shows minor changes with respiration. The basic frequency of the AC component varies with the heart rate and is superimposed on the DC baseline.

#### **Uses of PPG**

Medical devices based on PPG technology are widely used in various applications

- |                                     |                                  |
|-------------------------------------|----------------------------------|
| • Clinical physiological monitoring | • Respiration                    |
| • Blood oxygen saturation           | • Vascular assessment            |
| • Blood pressure                    | • Arterial disease               |
| • Cardiac output                    | • Arterial compliance and ageing |
| • Heart rate                        | • Venous assessment              |

#### **Wearable Devices**

Using this technology, wearable pulse rate monitors have been developed. These low-cost and small devices have high-intensity green light-emitting diodes (LEDs) and photodetectors that help reliable monitoring of the pulse rate in a non-invasive manner.

These devices have a sensor that monitors minor variations in the intensity of light transmitted through or reflected from the tissue. These intensity changes are associated with changes in blood flow through the tissue and provide vital cardiovascular information such as the pulse rate.

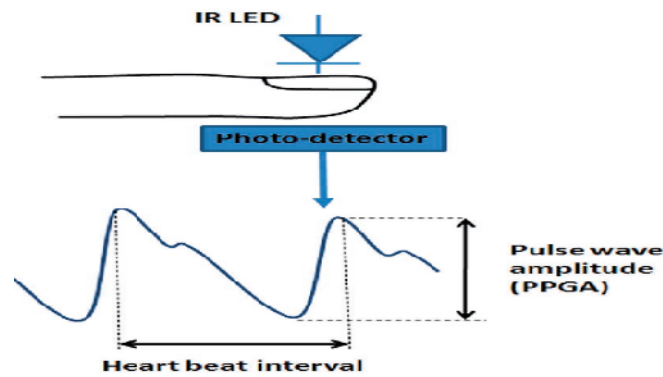

### **Body plethysmography**

Body plethysmography is a simple, painless test that takes lung volume measurements. Lung volume is the amount of air you inhale and exhale. The test involves sitting in an airtight booth and blowing into a mouthpiece while a computer records measurement. Body plethysmography helps diagnose respiratory diseases with similar symptoms, including asthma, pulmonary fibrosis, and chronic obstructive pulmonary disease (COPD).

Body plethysmography is only one method used to diagnose and manage respiratory diseases. Discuss all your testing options with your doctor to understand which tests are best for you. Resistance also may be used to determine the response of obstructed patients to bronchodilator medications.

### **Why is body plethysmography used?**

Body plethysmography is the most accurate method and sometimes the only way to take certain lung volume measurements. Lung volume is the amount of air you breathe in and out of your lungs. There are many kinds of lung volume measurements, which are measured using various pulmonary function tests, such as spirometry.

Body plethysmography can diagnose respiratory diseases earlier than spirometry. It also helps your doctor determine if your symptoms are due to a restrictive or an obstructive disease.

### **How is body plethysmography performed?**

Body plethysmography will be performed in a hospital pulmonary function lab or sometimes in a pulmonologist's office. Lung volume measurements take as little as three minutes, but the entire procedure will take about 20 to 30 minutes.

Proper breathing technique is important for accurate body plethysmography measurements and may take a bit of practice to master.

Body plethysmography generally involves these steps:

- You will loosen tight or restrictive clothing.
- You will sit or stand inside a clear, airtight chamber or booth and spend about 45 seconds acclimating to the temperature in the booth.
- You will inhale and exhale through a mouthpiece against a closed shutter device to a particular volume. Your pulmonary function technologist will instruct you to use different breathing techniques, such as panting and normal breathing.
- Your chest volume will expand and increase the pressure in the box as you breathe against the shutter. This pressure reading determines lung volume measurements.
- Your pulmonary function technologist may perform other pulmonary function tests in the booth, such as spirometry and lung diffusion capacity.

A **pulmonary function technologist** usually performs body plethysmography. A pulmonary function technologist has specialized training and education to perform pulmonary function tests safely and accurately.

## Risks and potential complications

Body plethysmography is a safe procedure without serious risks or complications. However, people with the following conditions may not tolerate body plethysmography:

- Claustrophobia
- Mental confusion
- Any condition requiring continuous oxygen therapy that cannot be stopped to take the test

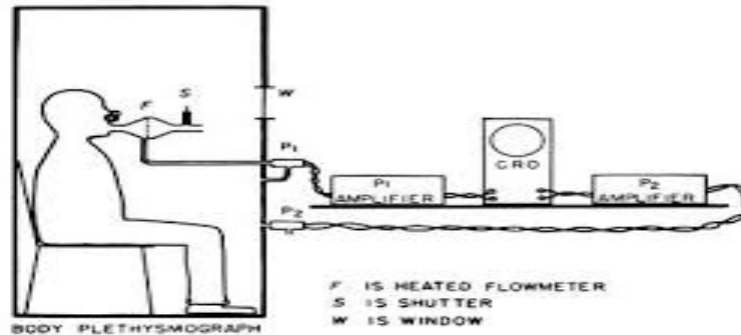

## Blood Glass Analyser

A blood gas test measures the amount of oxygen and carbon dioxide in the blood. It may also be used to determine the pH of the blood, or how acidic it is. The test is commonly known as a blood gas analysis or arterial blood gas (ABG) test.

Your red blood cells transport oxygen and carbon dioxide throughout your body. These are known as blood gases.

As blood passes through your lungs, oxygen flows into the blood while carbon dioxide flows out of the blood into the lungs. The blood gas test can determine how well your lungs are able to move oxygen into the blood and remove carbon dioxide from the blood.

Imbalances in the oxygen, carbon dioxide, and pH levels of your blood can indicate the presence of certain medical conditions. These may include:

- kidney failure
- heart failure
- uncontrolled diabetes
- hemorrhage
- chemical poisoning
- Drug overdoses
- shock

## **Why is a blood gas test done?**

A blood gas test provides a precise measurement of the oxygen and carbon dioxide levels in your body. This can help your doctor determine how well your lungs and kidneys are working.

This is a test that is most commonly used in the hospital setting to determine the management of acutely ill patients. It doesn't have a very significant role in the primary care setting, but may be used in a pulmonary function lab or clinic.

Your doctor may order a blood gas test if you're showing symptoms of an oxygen, carbon dioxide, or pH imbalance. The symptoms can include:

- shortness of breath
- difficulty breathing
- confusion
- nausea

A blood gas test is often ordered along with other tests, such as a blood glucose test to check blood sugar levels and a creatinine blood test to evaluate kidney function.

Blood gas analysers consist of three electrodes measuring pH,  $P_{CO_2}$ , and  $P_{O_2}$  at 37°C. From these outputs, internal computers calculate  $O_2$  saturation, base excess, bicarbonate, and other derived variables such as the compensation by the body for acid-base abnormalities. Arterial  $P_{O_2}$  and  $P_{CO_2}$  can be approximated using heated skin surface 'transcutaneous' electrodes, which are commonly used in premature infants and nurseries. Haemoglobin oxygen saturation,  $SO_2\%$ , is also directly measured by multiwavelength blood oximeters. Arterial  $SO_2$  is approximated by pulse oximeters, which detect the arterial pulsatile variations in red and infrared light penetrating a finger, ear, or other tissue,

Interpretation of blood gases and acid–base balance is briefly discussed. Figures include schema of the three electrodes, a pulse oximeter probe, an acid–based compensation diagram, and photographs of the first three-function blood gas analyser, a combined  $P_{O_2}P_{CO_2}$  transcutaneous electrode in use on a child, and a pulse oximeter probe on a finger.



### **PH of Blood**

- The pH scale, otherwise known as the acid-base scale, runs from 0 to 14. It measures how acidic a solution of a substance in water is. For example, pure water has a pH of 7.
- Solutions with a low pH have a high concentration of hydrogen ions and are acidic. Solutions with a high pH have a lower concentration of hydrogen ions and are alkaline, or basic.
- The pH scale is a compact scale, and small changes in pH represent big leaps in acidity.
- Electrodes for Blood pH Measurement: Several types of electrodes have been described in literature for the measurement of blood pH. They are all of the glass electrode type but made in different
- Typically, a micro-electrode for clinical applications requires only 20–25  $\mu$ l of capillary blood for the determination of pH. The electrode is enclosed in a water jacket with circulating water at a constant temperature of 38°C. The water contains 1% NaCl for shielding against static interference. The capillary is protected with a polyethylene tubing. The internal reference electrode is silver/silver chloride and the calomel reference electrode is connected to a small pool of saturated KCl, through a porous pin. An accuracy of 0.001 pH can be obtained with this electrode against a constant buffer
- Quite often, combination electrodes comprising both measuring and reference electrodes offer single-probe convenience for all pH measurements.
- Several instruments offer the ability to measure pH in small containers with as little as 250  $\mu$ l of the sample
- The pH of blood is found to change linearly with temperature in the range of 18° to 38°C.
- The temperature coefficient for the pH of blood is 0.0147 pH unit per degree centigrade. This necessitates the use of a highly accurate temperature-controlled bath to keep the electrodes with the blood sample at 37°C  $\pm$  0.01°C.
- Buffer Solutions: Buffer solutions are primarily used for (i) creation and maintenance of a desired, stabilized pH in a solution and (ii) standardization of electrode chains for pH measurements. A buffer is, therefore, a substance which by its presence in a solution is capable of counteracting pH changes in the solution as caused by the addition or the removal of hydrogen ions. Buffer solutions are characterized by their pH value.



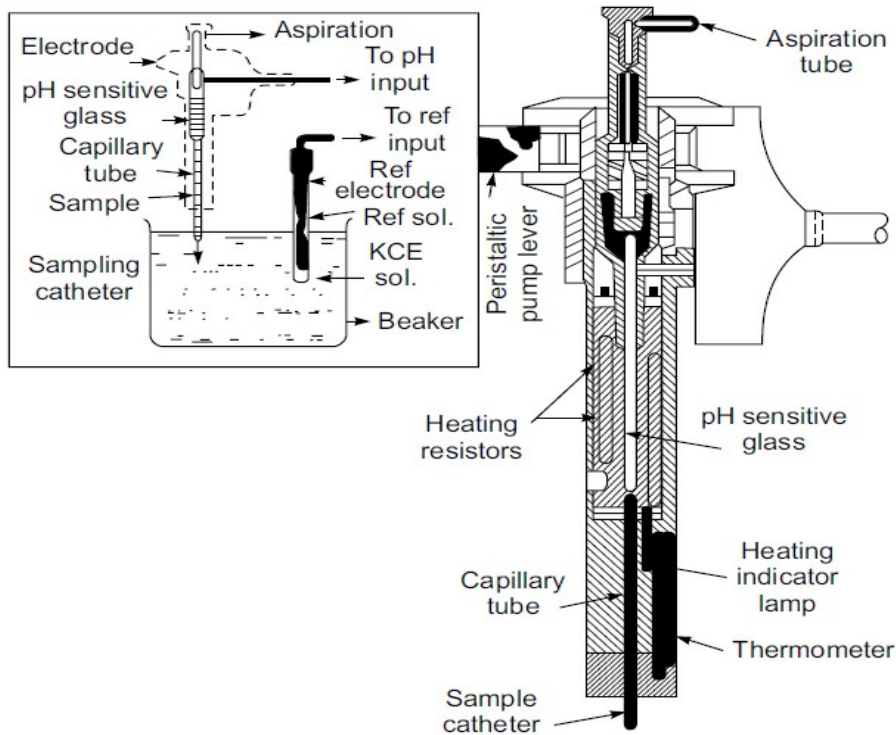

*Microcapillary electrode for measurement of blood pH (Courtesy: Corning)*

### Normal blood pH levels

The pH of blood in the arteries should be between **7.35 and 7.45** for the body's metabolic processes and other systems to work well.

### Changes in pH blood level

The pH of the blood can change in both directions.

Acidosis occurs when the blood is too acidic, with a pH below 7.35. Alkalosis occurs when the blood is not acidic enough, with a pH above 7.45.

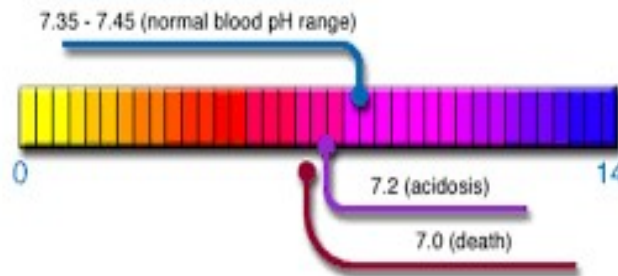

There are four main ways in which blood pH can change:

- **Metabolic acidosis:** This occurs due to reduced bicarbonate or increased acid levels.
- **Respiratory acidosis:** This occurs when the body removes less carbon dioxide than usual.
- **Metabolic alkalosis:** This occurs due to increased bicarbonate or reduced acid levels.
- **Respiratory alkalosis:** This occurs when the body removes more carbon dioxide than usual.

### Measurement of blood pCO<sub>2</sub>, pO<sub>2</sub>

#### Measurement of pCO<sub>2</sub>

- The blood pCO<sub>2</sub> is the partial pressure of carbon dioxide of blood taken anaerobically. It is expressed in mmHg and is related to the percentage CO<sub>2</sub> as follows:

$$pCO_2 = \text{Barometric pressure} - \text{water vapour pressure} \times \frac{\%CO_2}{100}$$

- All modern blood gas analysers make use of a pCO<sub>2</sub> electrode. It basically consists of a pH sensitive glass electrode having a rubber membrane stretched over it, with a thin layer of water separating the membrane from the electrode surface.
- The technique is based on the fact that the dissolved CO<sub>2</sub> changes the pH of an aqueous solution. The CO<sub>2</sub> from the blood sample diffuses through the membrane to form H<sub>2</sub>CO<sub>3</sub>, which dissociates into (H<sup>+</sup>) and (HCO<sub>3</sub><sup>-</sup>) ions. The resultant change in pH is thus a function of the CO<sub>2</sub> concentration in the sample. The emf generated was found to give a linear relationship between the pH and the negative logarithm of pCO<sub>2</sub>.

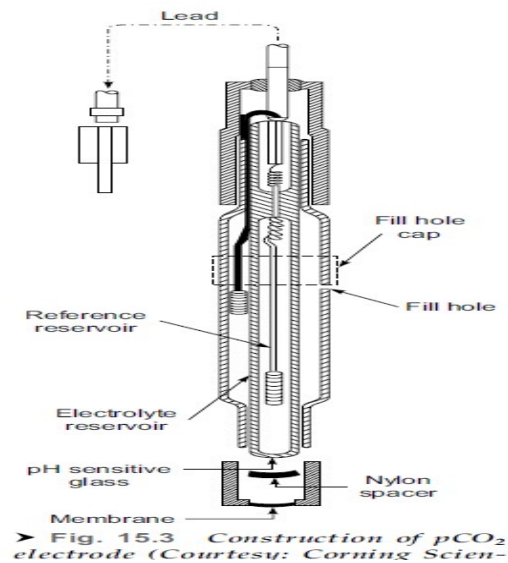

- The basic construction of the electrode was modified to a degree that made it suitable for routine laboratory use. In the construction worked out by them, the water layer was replaced by a thin film of an aqueous sodium bicarbonate (NaHCO<sub>3</sub>) solution. The rubber membrane was also replaced by a thin Teflon membrane, which is permeable to CO<sub>2</sub> but not to any other ions, which might alter the pH of the bicarbonate solution. The CO<sub>2</sub> from the blood diffuses into the bicarbonate solution. There will be a drop in pH due to CO<sub>2</sub> reacting with water forming carbonic acid. The pH falls by almost one pH unit for a ten-fold increase in the CO<sub>2</sub> tension of the sample. Hence, the pH change is a linear function of the logarithm of the CO<sub>2</sub> tension.
- Further improvements in stability and response time. They used a dilute solution of NaHCO<sub>3</sub> (0.0001 N), which helped in reducing the response time but the drift introduced posed serious problems. The compromise between response time and drift was achieved by using a 0.001 N solution of NaHCO<sub>3</sub>. Silver/silver chloride reference electrode was replaced by a calomel cell which was made an integral part of the electrode
- Further improvement constructed a pCO<sub>2</sub> electrode using 0.5 mm polyethylene as a membrane and used no separator between the glass surface and this membrane. They added carbonic anhydrase to the electrolyte. The response time was found to be 6 seconds for 90% of a step change from 2% to 5% CO<sub>2</sub>. Use of a pCO<sub>2</sub> electrode for the measurement of blood or plasma pCO<sub>2</sub> has been studied repeatedly and has been found to be accurate, precise and expedient.
- The emf generated by a pCO<sub>2</sub> electrode is a direct logarithmic function of pCO<sub>2</sub>. It is observed that a ten-fold change in pCO<sub>2</sub> causes the potential to change by 58 ± 2 mV. The pH versus log pCO<sub>2</sub> relationship is linear within ±0.002 pH unit from 1 to 100% carbon dioxide.
- It is essential to maintain the temperature of the electrode assembly constant within close limits.
- The combined effects of temperature change upon the sensitivity of the pH electrode and upon the pCO<sub>2</sub> of the blood sample amount to a total variation in sensitivity of 8% per degree centigrade.



- Calculated Bicarbonate, Total CO<sub>2</sub> and Base Excess: Acid-base balance determinations are based on several calculations, which are routinely used in conjunction with blood pH and gas analysis. An accurate picture of acid-base balance can be determined from the equilibrium:

### Measurement of pO<sub>2</sub>

The partial pressure of oxygen in the blood or plasma indicates the extent of oxygen exchange between the lungs and the blood, and normally, the ability of the blood to adequately perfuse the body tissues with oxygen. The partial pressure of oxygen is usually measured with a polarographic electrode. There is a characteristic polarizing voltage at which any element in solution is predominantly reduced and in the case of oxygen, it is 0.6 to 0.9 V. In this voltage range, it is observed that the current flowing in the electrochemical cell is proportional to the oxygen concentration in the solution.

Most of the modern blood gas analysers utilize an oxygen electrode for measuring oxygen partial pressure. This type of electrode consists of a platinum cathode, a silver/silver chloride anode in an electrolyte filling solution and a polypropylene membrane. The electrode is of a single unit construction and contains the reference electrode also in its assembly.

The entire unit is separated from the solution under measurement by the polypropylene membrane.

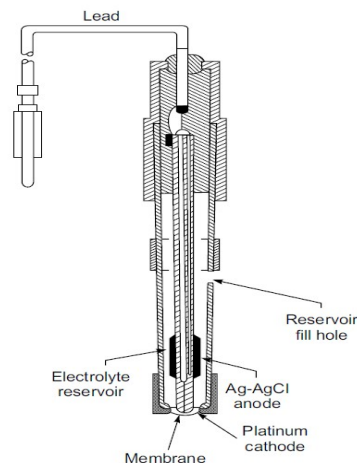

➤ Fig. 15.4 Constructional details of pO<sub>2</sub> electrode (Courtesy: Corning Scientific Instruments, U.S.A.)

- Oxygen from the blood diffuses across the membrane into the electrolyte filling solution and is reduced at the cathode. The circuit is completed at the anode, where silver is oxidized, and the magnitude of the resulting current indicates the partial pressure of oxygen. The reactions occurring at the anode and cathode are:
- The Clark electrode for measuring pO<sub>2</sub> has been extensively studied and utilized. It is found to be of particular advantage for measuring blood samples.
- The principal advantages are:
  - (i) Sample size required for the measurement can be extremely small,
  - (ii) The current produced due to pO<sub>2</sub> at the electrode is linearly related to the partial pressure of oxygen,
  - (iii) The electrode can be made small enough to measure oxygen concentration in highly localized areas,
  - (iv) The response time is very low, so the measurements can be made in seconds.
- The ammonium hydroxide on the tip of the electrode (10% solution), with a gentle, rotary motion using a swab is used. The silver chloride gets dissolved in ammonium hydroxide. It is then flushed with distilled water.
- The polarographic electrodes usually exhibit ageing effect by showing a slow reduction in current over a period of time, even though the oxygen tension in the test solution is maintained at a constant level. Therefore, it needs frequent calibration.
- The measurement of current developed at the pO<sub>2</sub> electrode due to the partial pressure of oxygen presents special problems.

- Measurement of oxygen electrode current is made by using high input impedance, low noise and low current amplifiers. Field effect transistors usually form the input stage of the preamplifiers.

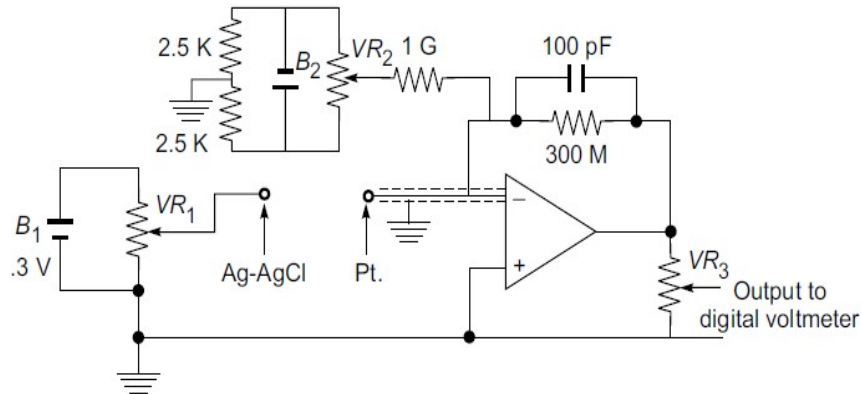

► Fig. 15.6 Current amplifier for use with  $pO_2$  electrode

**Increased  $pCO_2$  is caused by:**

- Pulmonary edema
- Obstructive lung disease

**Decreased  $pCO_2$  is caused by:**

- Hyperventilation
- Hypoxia
- Anxiety

**$PO_2$  (partial pressure of oxygen)** reflects the amount of oxygen gas dissolved in the blood. It primarily measures the effectiveness of the lungs in pulling oxygen into the blood stream from the atmosphere.

**Elevated  $pO_2$  levels are associated with:**

- Increased oxygen levels in the inhaled air
- Polycythemia

**Decreased  $PO_2$  levels are associated with:**

- Decreased oxygen levels in the inhaled air
- Anemia
- Heart decompensation
- Chronic obstructive pulmonary disease
- Restrictive pulmonary disease
- Hypoventilation

ANALYTE	Normal Value	Units
pH	7.35 - 7.45	
PCO2	35 - 45	mm Hg
PO2	72 - 104	mm Hg`
[HCO3]	22 - 30	meq/L
SaO2	95-100	%
Anion Gap	12 $\pm$ 4	meq/L
$\Delta$ HCO3	+2 to -2	meq/L

### **Finger-tip oxymeter**

Pulse oximetry is a non-invasive and painless test that measures your oxygen saturation level, or the oxygen levels in your blood. It can rapidly detect even small changes in how efficiently oxygen is being carried to the extremities furthest from the heart, including the legs and the arms.

The pulse oximeter is a small, clip-like device that attaches to a body part, like toes or an earlobe. It's most commonly put on a finger, and it's often used in a critical care setting like emergency rooms or hospitals

The purpose of pulse oximetry is to check how well your heart is pumping oxygen through your body. It may be used to monitor the health of individuals with any type of condition that can affect blood oxygen levels, especially while they're in the hospital. These conditions include:

- chronic obstructive pulmonary disease (COPD)
- asthma
- pneumonia
- lung cancer
- anaemia
- heart attack or heart failure
- congenital heart defects

### **Working**

During a pulse oximetry reading, a small clamp-like device is placed on a finger, earlobe, or toe. Small beams of light pass through the blood in the finger, measuring the amount of oxygen. It does this by measuring changes of light absorption in oxygenated or deoxygenated blood. This is a painless process.

The pulse oximeter will thus be able to tell you your oxygen saturation levels along with your heart rate.

### **Procedure steps**

Pulse oximetry may be used in both inpatient and outpatient settings. In some cases, your doctor may recommend that you have a pulse oximeter for home use.

The pulse oximetry process is as follows:

- Most commonly, a clip-like device will be placed on your finger, earlobe, or toe. You may feel a small amount of pressure, but there is no pain or pinching. In some cases, a small probe may be placed on your finger or forehead with a sticky adhesive. You may be asked to remove your fingernail polish if it's being attached to a finger.
- You'll keep the probe on for as long as needed to monitor your pulse and oxygen saturation. When monitoring physical activity capabilities, this will be during the extent of the exercise and during the recovery period. During surgery, the probe will be attached beforehand and removed once

you're awake and no longer under supervision. Sometimes, it will only be used to take a single reading very quickly.

- Once the test is over, the clip or probe will be removed.

### **Pulse oximetry readings**

Pulse oximetry is typically a fairly accurate test. This is especially true when using high-quality equipment found in most medical offices or hospital settings. It consistently provides results within a 2-percent difference either way of what it truly is. If your reading was 82 percent, for example, your true oxygen saturation level may be anywhere from 80 to 84 percent. However, the quality of the waveform and assessment of the individual must be considered. Factors such as movement, temperature, or nail polish can impact the accuracy.

Typically, more than 89 percent of your blood should be carrying oxygen. This is the oxygen saturation level needed to keep your cells — and your body — healthy. While having an oxygen saturation below this temporarily is not believed to cause damage, repeat or consistent instances of lowered oxygen saturation levels may be damaging.

An oxygen saturation level of 95 percent is considered normal for most healthy individuals. A level of 92 percent indicates potential hypoxemia, or deficiency in oxygen reaching tissues in the body.



### **Erythrocyte Sedimentation Rate (ESR)**

An erythrocyte sedimentation rate (ESR) is a type of blood test that measures how quickly erythrocytes (red blood cells) settle at the bottom of a test tube that contains a blood sample. Normally, red blood cells settle relatively slowly. A faster-than-normal rate may indicate inflammation in the body. Inflammation is part of your immune response system. It can be a reaction to an infection or injury. Inflammation may also be a sign of a chronic disease, an immune disorder, or other medical condition

An ESR test can help determine if you have a condition that causes inflammation. These include **arthritis**, **vasculitis**, or **inflammatory bowel disease**. An ESR may also be used to monitor an existing condition.

#### **Why do I need an ESR?**

Symptoms of an inflammatory disorder. These include:

- Headaches
- Fever
- Weight loss
- Joint stiffness
- Neck or shoulder pain
- Loss of appetite
- Anemia

#### **What do the results mean?**

If your ESR is high, it may be related to an inflammatory condition, such as:

- Infection
- Rheumatoid arthritis
- Rheumatic fever
- Vascular disease
- Inflammatory bowel disease
- Heart disease
- Kidney disease
- Certain cancers

Sometimes the ESR can be slower than normal. A slow ESR may indicate a blood disorder, such as:

- Polycythemia
- Sickle cell anemia

- Leukocytosis, an abnormal increase in white blood cells

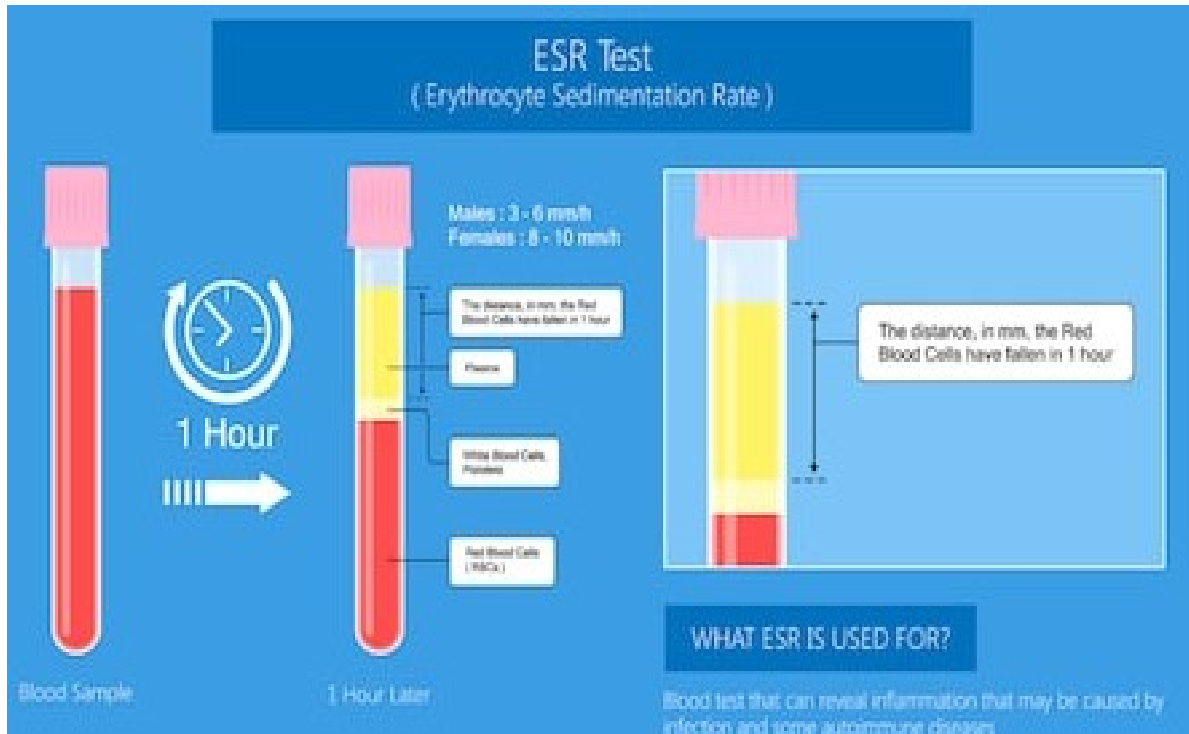

### **Galvanic Skin Response (GSR)**

Whenever you experience an emotional reaction to a stimulus, your body responds by producing sweat, which increases your skin's electrical conductivity (called electrodermal activity). Galvanic Skin Response (GSR) is a measure of skin conductivity, and is perhaps most well-known as an element of the polygraph (lie-detector) test.

GSR is a major component of our biometric toolkit here at Moore DM Group's Neuro-Fundraising Lab. We use GSR to understand what elements of fundraising campaigns are emotionally engaging for potential donors, and what elements fall flat.

### **How does GSR work?**

A GSR sensor allows us to measure sweat gland activity, which is related to emotional arousal. To measure GSR, we take advantage of the electrical properties of the skin. Specifically, how the skin resistance varies with sweat gland activity, i.e., the greater sweat gland activity, the more perspiration, and thus, less skin resistance. The most common measure of a GSR signal is not resistance, but conductance. Conductance is the opposite of resistance and is measured in siemens (Conductance =  $1 / \text{Resistance}$ ). The conductance makes the signal interpretation easier, since the greater the sweat gland activity, the higher the skin conductance.

The most common method to measure a GSR signal for emotional research purposes is based on a constant voltage system (exosmotic method). The GSR sensor applies a constant voltage—usually 0.5 V—to the two electrodes that are in contact with the skin. The circuit also contains a very small resistance compared to the skin resistance that is in series with the voltage supplier and the electrodes. The purpose of this circuit is to measure the skin conductance and its variation by applying Ohm's law (Voltage = Intensity x Resistance = Intensity/Conductance). As the voltage (V) is kept constant, skin conductance (C) can be calculated by measuring the current (I) flow through the electrodes. With this setup, any fluctuation in the current flow is due to a change in the electrical properties of the skin, and therefore in the sweat gland activity.

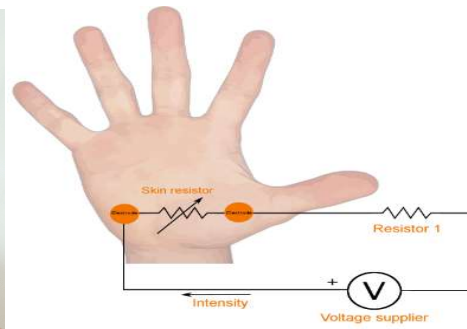

**POST MCQ:**

1. Whose measurements are important for myoelectric control of prosthetic devices?
  - a) VCG
  - b) ECG
  - c) EEG
  - d) EMG
 Answer: d
2. Blood flow detectors based on Doppler shift start detecting foetal pulses as early as in which week of pregnancy?
  - a) Tenth
  - b) Eleventh
  - c) Twelfth
  - d) Ninth
 Answer: b
3. Which of the following transducer is used to detect foetal heart movements over a wider area?
  - a) Piezo-electric
  - b) Ultrasonic
  - c) Array
  - d) Pressure
 Answer: a
4. Which section of the clinical laboratory deals with determinations of the number and characteristics of the constituents of the blood, particularly the blood cells?
  - a) Chemistry
  - b) Haematology
  - c) Microbiology
  - d) Sample collection
 Answer: b
5. What is the percentage of blood plasma and the blood cells respectively in blood volume?
  - a) 60, 40
  - b) 40, 60
  - c) 70, 30
  - d) 30, 70
 Answer: a
6. The ratio of the radiant power transmitted by a sample to the radiant power incident on the sample is known as \_\_\_\_\_.
  - a) Absorbance
  - b) Transmittance
  - c) Optical density
  - d) Photometric concentration
 Answer: b

## UNIT -III

### ELECTRICAL PARAMETERS ACQUISITION AND ANALYSIS

#### AIM:

To learn about various sensing and measurement devices of electrical and non-electrical origin

#### PRE MCQ

1. Source of Bioelectric potential is \_\_\_\_\_ in nature.
  - a) Electronic
  - b) Electric
  - c) Ionic
  - d) MechanicalAnswer: c
2. Electrodes make a transfer from the \_\_\_\_\_ in the tissue to the electronic conduction which is necessary to make measurements.
  - a) Electronic conduction
  - b) Ionic conduction
  - c) Electric conduction
  - d) Impulsive conductionAnswer: b
3. Deep-seated electrodes indicates the electric potential difference arising \_\_\_\_\_ the living tissues or cells.
  - a) Inside
  - b) Outside
  - c) Around
  - d) AdjacentAnswer: a
4. Recording electrical activities associated with heart is known as \_\_\_\_\_.
  - a) EEG
  - b) EOG
  - c) EMG
  - d) ECGAnswer: d
5. Which of the following is a preferred electrode for measuring EMG?
  - a) Surface electrodes
  - b) Needle electrodes
  - c) Pregelled electrodes
  - d) Scalp electrodesAnswer: b
6. Generally what is the material of needle electrodes?
  - a) Stainless steel
  - b) Copper
  - c) Lead
  - d) IronAnswer: a



## THEORY:

### ELECTRODES

**Electrodes** are devices that convert ionic potentials into electronic potentials. The type of electrode used for the measurements depends on the anatomical location of the bioelectric event to be measured. In order to process the signal in electronic circuits, it will be better to convert ionic conduction into electronic conduction.

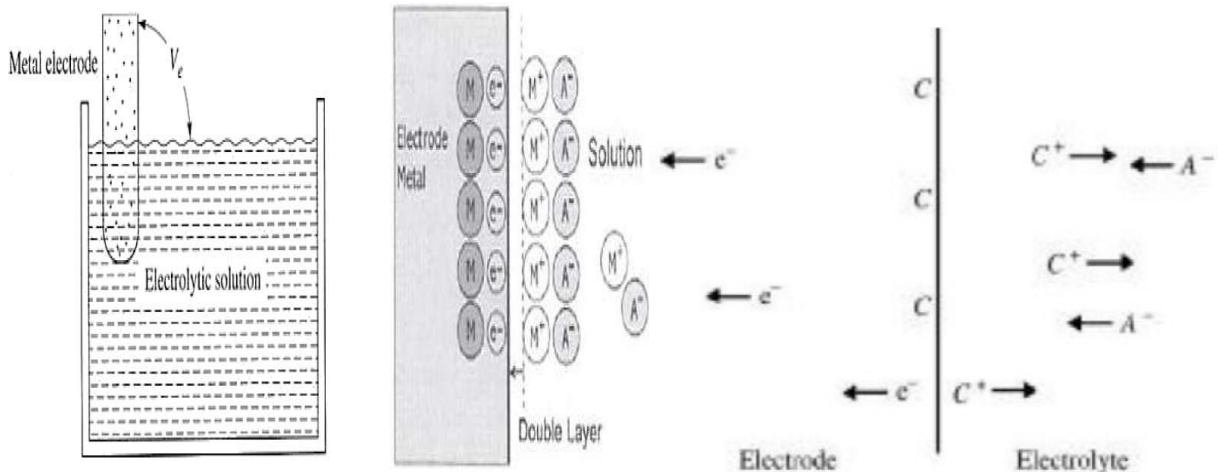

### Electrode Theory

To measure bioelectric potentials, a transducer is required. Electrical signals produced by various body activities are used in monitoring / diagnosis.

- In order to measure and record potentials and, hence, currents in the body, it is necessary to provide some interface between the body and the electronic measuring apparatus. Bio-potential electrodes carry out this interface function.
- A transducer consists of two electrodes, which measure ionic potential difference between two points.
- The designation of the Bio potential waveform ends with “Gram”. The name of the instrument bio potential normally ends with “Graph”. Propagation of action potential through different body tissues produces final waveform recorded by electrodes
- Electrical activity is explained by differences in ion concentrations within the body (sodium,  $Na^+$ ; chloride,  $Cl^-$ ; potassium,  $K^+$ ). A potential difference (voltage) occurs between 2 points with different ionic concentrations
- Propagation of action potential through different body tissues produces final waveform recorded by electrodes
- Electrical activity is explained by differences in ion concentrations within the body (sodium,  $Na^+$ ; chloride,  $Cl^-$ ; potassium,  $K^+$ ). A potential difference (voltage) occurs between 2 points with different ionic concentrations

### Nernst Relation

- It can be shown that an electric potential  $E$  will exist between the solutions on either side of the membrane, based upon the relative activity of the permeable ions in each of these solutions. This relationship is known as the Nernst equation.
- The relationship between the ionic concentration (activity) and the electrode potential is given by the Nernst equation:
- When no electric current flows between an electrode and the solution of its ions or across an ion permeable membrane, the potential observed should be the half-cell potential or the Nernst potential, respectively. If, however, there is a current, these potentials can be altered.

$$E = -\frac{RT}{nF} \ln\left(\frac{C_1 f_1}{C_2 f_2}\right)$$

where

- $R$  – universal gas constant [ 8.31 J/(mol K) ]
- $T$  – absolute temperature in K
- $n$  – valence of the electrode material
- $F$  – Faraday constant [ 96,500 C/(mol/valence) ]
- $C_1, C_2$  – Concentration of ion on either side of membrane
- $f_1, f_2$  – Respective activity coefficients of ions on either side

### Equivalent circuit for bio-potential electrode

- Where  $R_d$  and  $C_d$  are components that represent the impedance associated with the electrode-electrolyte interface and polarization at this interface.
- $R_s$  is the series resistance associated with electrode materials.
- The battery  $E_{hc}$  represents the half-cell potential

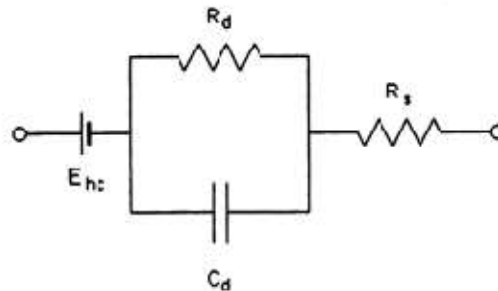

### Classification of Electrodes

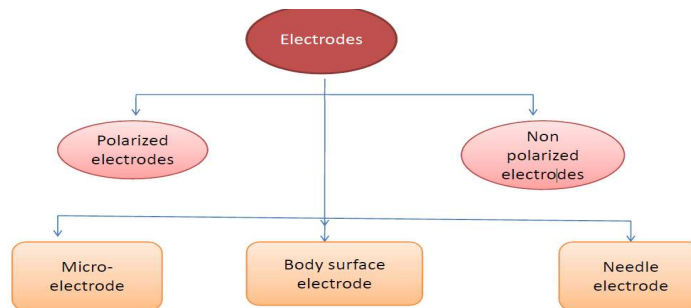

Electrode is an interface to connect the measurement devices and measure bioelectrical potentials, electrode is used as an interface, however. The electrode is also a transducer

#### Perfectly Polarizable Electrodes

– Perfectly polarizable electrodes are those in which no actual charge crosses the electrode-electrolyte interface when a current is applied.

– there has to be current across the interface and the electrode behaves as though it were a **capacitor**



#### Perfectly Polarizable Electrodes or Perfectly Reversible

– Perfectly non-polarizable electrodes are those in which current passes freely across the electrode-electrolyte interface, requiring no energy to make the transition.

– Thus, for perfectly non-polarizable electrodes there are no overpotentials.

– Electrode interface impedance is represented as a **resistor**



## Limb Electrodes

Limb leads are made up of 4 leads placed on the extremities: left and right wrist; left and right ankle. The lead connected to the right ankle is a neutral lead, like you would find in an electric plug. It is there to complete an electrical circuit and plays no role in the ECG itself.

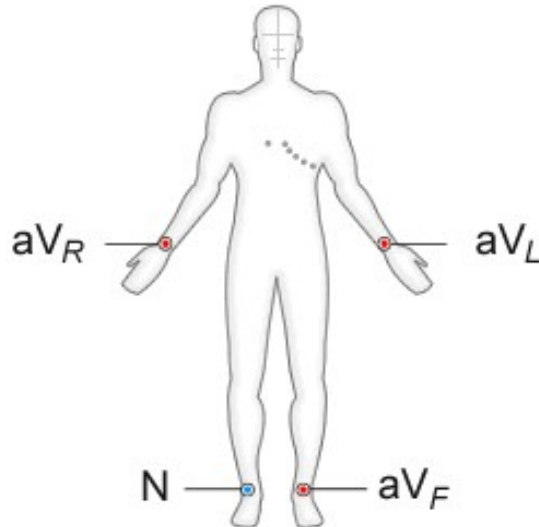

## Micro Electrodes

Microelectrodes are electrodes with tips having tips sufficiently small enough to penetrate a single cell in order to obtain readings from within the cell.

- The tips must be small enough to permit penetration without damaging the minute cell.
- The main functions of microelectrodes are potential recording and current injection.
- Microelectrodes are having high impedances in mega ohm range because of their smaller size.

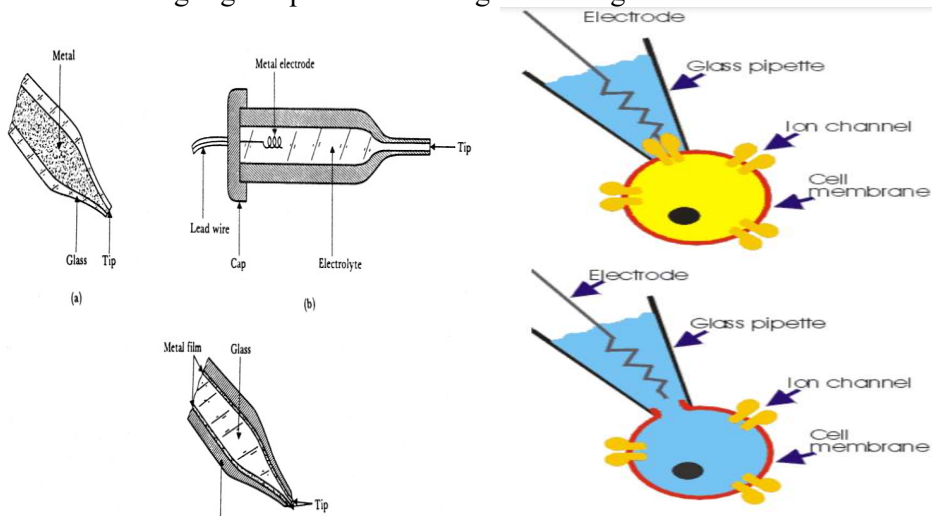

## **Types**

- Metal microelectrode
- Micropipette

### **Metal microelectrode**

Metal microelectrodes are formed by electrolytic ally etching the tip of fine tungsten to the desired size and dimension.

Then the wire is coated almost to the tip with any type of insulating material.

The metal-ion interface takes place where the metal tip contacts the electrolyte

The main features of metal microelectrodes are

1. Very good S/N ratio
2. Strong enough to penetrate
3. High biocompatibility

### **Micropipette**

The micropipette type of microelectrode is a glass micropipette with its tip drawn out to the desired size

The micropipette is filled with an electrolyte which should be compatible with the cellular fluids

A micropipette is a small and extremely fine pointed pipette used in making microinjections.

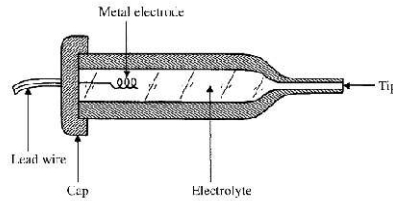

### **Surface Electrodes**

Surface electrodes are those which are placed in contact with the skin of the subject in order to obtain bioelectric potentials from the surface.

- Body surface electrodes are of many sizes and types. In spite of the type, any surface electrode can be used to sense ECG, EEG, EMG etc.

### **Immersion electrodes**

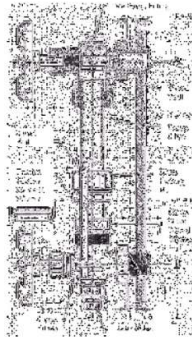

They are one of the first type of bioelectric measuring electrodes.

- Immersion electrodes were simply bucketing of saline solution in which the subject placed his hands and feet.
- So, it was not a comfortable type of measurement and hence it was replaced with plate electrodes.

### **Plate electrodes**

#### **Body-Surface Recording Electrode**

##### **Metal-Plate Electrodes**

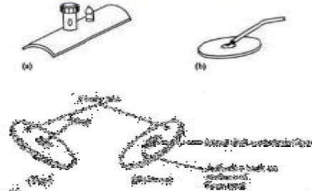

- The plate electrodes have generally smaller contact area and they do not totally seal on the patient.
- The electrode slippage and displacement of plates were the major difficulties faced by these types of electrodes because they have a tendency to lose their adhesive ability as a result of contact with fluids on or near the patient.
- Since these types of electrodes were very sensitive, it led to measurement errors

### Disposable electrodes



Normally plate electrodes, floating electrodes etc can be used more than one time.

- This requires the cleaning and cares after each use.
- We can use disposable electrodes which can be used only once and be disposed after the use.
- These types of electrodes are now widely used

### Suction electrodes

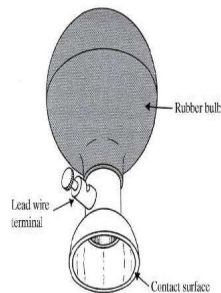

These types of electrodes are well suited for the attachment to flat surfaces of body and to regions where the underlying tissue is soft, due to the presence of contact surface.

- An advantage of these type of electrodes is that it has a small surface area.
- These types of electrodes are mainly used for the measurement of ECG.
- Suction electrodes used a plastic syringe barrel to house suction tubing and input cables to an AC amplifier

### Ear clip & Scalp electrodes:



These types of electrodes are widely used in the measurement of EEG exclusively.

- Scalp electrodes can provide EEG easily by placing it over bare head. A typical ear clip electrode is shown in figure below.
- The most common method for EEG measurement is 10 – 20 electrode placement system and here we use scalp electrode usually.

- They can avoid measurement errors and movement errors. During labour internal monitoring may be needed and is usually in the form of an electrode placed under the baby's scalp.
- It is called fetal scalp electrode which is used to monitor baby's heartbeat while still in uterus.

### Needle Electrodes

To reduce the interface and noise (artifact) caused due to electrode movement, during the measurement of EEG, EMG etc we can use small sub-dermal needle electrodes which penetrate the scalp.

- The needle electrodes are not inserted into the brain. They nearly penetrate the skin; they are simply inserted through a small section of the skin just beneath the skin parallel to it.

The needle electrodes for EMG measurement consist of fine insulated wires placed in such way that their tips are in contact with the muscle, nerve or other tissues from which the measurement is made. The needle creates the hole necessary for insertion and the wires forming the electrodes are carried inside it.

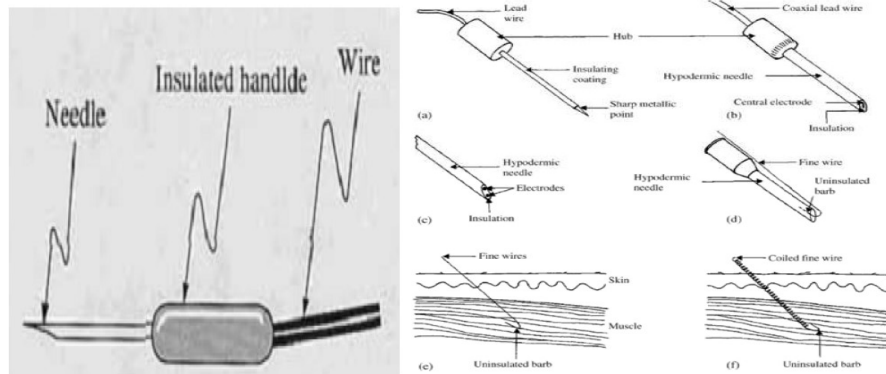

One of the main advantages of needle electrodes is that they are less susceptible to movement errors than surface electrodes.

- The needle electrodes have lower impedances when compared to surface electrodes as it makes direct contact with the sub-dermal tissues or intracellular fluid.

### Amplifier

Operational amplifiers, universally referred to as op-amps, are the most commonly used electronic devices used to amplify small voltages in biomedical devices. They consist of networks of many transistors, and are active devices in the sense that they require a DC voltage to drive them.

The op-amp amplification factor, referred to as gain, is usually specified in terms of the gain-bandwidth product (GBWP), which is the product of the amplifier's bandwidth and the gain over that bandwidth. If the GBWP of an op-amp is specified to be 1 MHz, it means that it will work up to 1 MHz with unit gain without excessively distorting the signal. The same device, when incorporated into a circuit with a gain of 10, only works up to a frequency of 100 kHz.

Configuration	Properties
Inverting	Active gain and the output has opposite polarity to the input
Non-inverting	Active gain and the output has the same polarity as the input
Integrating	Amplifies the time integral of the input signal
Differentiating	Amplifies the time differential of the input signal
Buffer	Unity gain: buffers the input with respect to different loads
Differential	Amplifies the difference between two input signals

### **Circuit Analysis Rules for Op-Amps**

The input resistance of an op-amp is very high, approximately 1 MΩ, and so with typical driving voltages of between 5 and 15 volts the input currents  $i_+$  (to the noninverting terminal) and  $i_-$  (to the

inverting terminal) are between 5 and 15 picoamps. Therefore, a simplifying assumption used extensively in op-amp circuit analysis is that there is no current flow into the device.

$$i_+ = i_- = 0$$

The gain of the op-amp is defined as the ratio of the output voltage,  $V_{out}$ , to the input voltage,  $(V_{out}/V_{in})$ . The maximum output voltage, known as the saturation voltage, is equal to the driving voltage,  $V_{cc}$ . Since the typical gain of an op-amp is 106, this means that the maximum voltage that can be amplified is  $\sim 5$  to  $15 \mu V$ . This is a very small value, and a second approximation used in circuit analysis is that this can be ignored

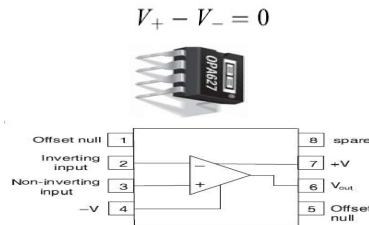

**Photograph of a single op-amp chip, and layout of the eight-pin op-amp**

### Inverting and Non-Inverting amplifiers

The circuit for an inverting amplifier the positive terminal of the input source ( $V_{in}$ ) is connected to the negative (inverting) terminal of the op-amp, and the positive terminal (non-inverting) of the op-amp is connected to ground. For simplicity, the driving voltages  $\pm V_{cc}$  are omitted from the circuit diagrams. The circuit for a non-inverting amplifier, the positive terminal of the input source is connected to the positive (non-inverting) terminal of the op-amp.

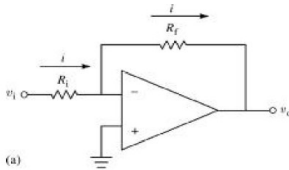

**Inverting Amplifier**

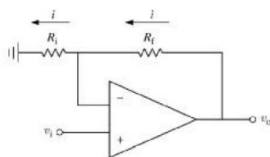

**Non-Inverting Amplifiers**

The differential amplifier is widely employed in integrated circuitry because it has both good bias stability and high gain without requiring large bypass capacitors.

The differential amplifier circuit that is used in IC op-amps. This is the circuit which explains a great deal about the put characteristics of the typical IC op-amps

- These are very important part of modern medical instrumentation. We need to amplify bio-potentials which are generated in the body at low levels with high source impedance.
- Bio-potentials amplifiers are required to increase signal strength while maintaining fidelity
- To take a weak bio-potential and increase its amplitude so that it can be processed, recorded or displayed
- To amplify voltage, power and current.
- In some cases a biopotential amplifier is used to isolate the load from the source current gain only

### Characteristics

1. High input impedance
2. Low output impedance
3. The bio potential amplifier must be sensitive to important frequency components of the bio-signal.
4. Bio potential amplifiers have a gain of **1000** or greater.
5. Most bio potential amplifiers are differential



### **Pre-amplifier**

The amplifiers employed include:

- (i) ac/dc universal amplifier with special features such as capacity neutralization, current injection, low leakage current and low dc drift suitable for intracellular measurements through high resistance fluid-filled electrodes or to make extracellular recordings through metal microelectrodes for EMG, EEG, EOG, etc.
- (ii) an ECG amplifier with full 12 lead selection and patient isolation.
- (iii) a transducer amplifier suited for bridge measurements on strain gauges, strain gauge-based blood pressure transducers, force transducers, resistance temperature devices and direct low level dc input signals.
- (iv) a dc amplifier used in conjunction with standard thermistor probes for the accurate measurement of temperature within the range of medical applications.

***Differential amplifier*** is one which will reject any common mode signal that appears simultaneously at both amplifier input terminals and amplifies only the voltage difference that appears across its input terminals. Most of the amplifiers used for measuring bioelectric signals are of the differential type.

***Ac coupled amplifiers*** have a limited frequency response and are, therefore, used only for special medical applications such as electrocardiograph machine. For electrocardiograms, an ac amplifier with a sensitivity, giving 0.5 mV/cm, and frequency response up to 1 kHz and an input impedance of 2 to 5 MW is used. For such applications as retinography, EEG and EMG, more sensitive ac amplifiers are required, giving a chart sensitivity of say 50 mV/cm with a high input impedance of over 10 MW.

***Carrier amplifiers*** are used with transducers which require an external source of excitation. They are characterized by high gain, negligible drift, extremely low noise and the ability to operate with resistive, inductive or capacitive type transducers. They essentially contain a carrier oscillator, a bridge balance and calibration circuit, a high gain ac amplifier, a phase-sensitive detector and a dc output amplifier.

***DC amplifiers*** are generally of the negative feedback type and are used for medium gain applications down to about 1 mV signal levels for full scale. They are not practical for very low level applications because of dc drift and poor common-mode rejection capabilities. They are usually employed as pen drive amplifiers in direct writing recorders.

***Chopper input dc amplifiers*** are preferred for low level inputs to instrumentation systems because of their high sensitivity, negligible drift and excellent common mode rejection capability. Their high frequency response is limited to about one half of the input chopper frequency.

***Chopper stabilized dc amplifiers*** are used for low level but preferably wideband applications such as oscilloscopes, tape recorders and light beam oscilloscope recorders. These are complex amplifiers having three amplifiers incorporated in the module. This includes an ac amplifier for signals above about 20 Hz, a dc chopper input amplifier for signals from about 20 Hz down to dc plus a wideband feedback stabilized dc amplifier.

***DC bridge amplifiers*** are employed with resistive transducers which require an external source of excitation. Essentially, the amplifier comprises of a stable dc excitation source, a bridge balance and calibration unit, a high gain differential dc amplifier and a dc output amplifier. They can be used as conventional dc high gain amplifiers and offer operating simplicity and high frequency response. These amplifiers are necessary for transducers used to measure temperature and blood pressure. The sensitivity in these cases may be 50 mV/cm with an input impedance of 50 kW.

## Differential amplifiers

A **differential amplifier** (also known as a difference amplifier) is a type of electronic amplifier that amplifies the difference between two input voltages but suppresses any voltage common to the two inputs. A differential amplifier is an analog circuit with two inputs ( $V_1$  and  $V_2$ ) and one output ( $V_0$ ) in which the output is ideally proportional to the difference between the two voltages. The formula for a simple differential amplifier can be expressed:

$$V_0 = A_d(V_1 - V_2)$$

- $V_0$  is the output voltage
- $V_1$  and  $V_2$  are the input voltages
- $A_d$  is the gain of the amplifier (i.e., the differential amplifier gain)

From the formula above, you can see that when  $V_1 = V_2$ ,  $V_0$  is equal to zero, and hence the output voltage is suppressed. But any difference between inputs  $V_1$  and  $V_2$  is multiplied (i.e. amplified) by the differential amplifier gain  $A_d$ .

This is why the differential amplifier is also known as a difference amplifier – the difference between the input voltages is amplified

Differential Amplifier Medical amplifiers designed for use in the input stage (preamplifiers) are mostly of the differential type. These types have three input terminals out of which one is arranged at the reference potential and the other two are live terminals. The differential amplifier is employed when it is necessary to measure the voltage difference between two points, both of them varying in amplitude at different rates and in different -patterns. Heart-generated voltages picked up by means of electrodes on the arms and legs, and brain-generated voltages picked up by the electrodes on the scalp are typical examples of signals whose measurement requires the use of differential amplifiers. The differential amplifier is an excellent device for use in the recording systems. Its excellence lies in its ability to reject common-mode interference signals which are invariably picked up by electrodes from the body along with the useful bioelectric signals.

Also, as a direct coupled amplifier, it has good stability and versatility. High stability is achieved because it can be insensitive to temperature changes which is Often the source of excessive drift in other configurations. It is versatile in that it may be adapted for a good many applications, e.g. applications requiring floating inputs and outputs Or for applications where grounded inputs and/or outputs are desirable.

Figure I shows such a circuit made Of two BJTs ( $Q_1$  and  $Q_2$ ) and two power supplies Of opposite polarity viz.,  $V_{CC}$  and  $-V_{EE}$  which uses three resistors among which two are the collector resistors,  $R_{C1}$  and  $R_{C2}$  (one for each transistor) While one is the emitter resistor  $R_E$  common to both transistors.

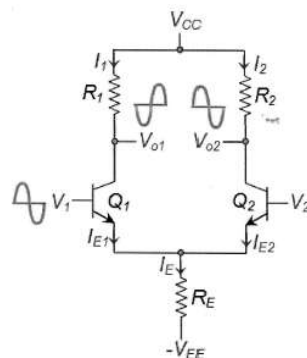

### **A BJT Differential Amplifier**

In this case, if the  $V_1$  at  $Q_1$  is sinusoidal, then as  $V_1$  goes On increasing, the transistor Starts to' conduct and this results in a heavy collector Current increasing the voltage drop across  $R_{C1}$ , causing a decrease in  $V_{01}$ . Due to the same effect, even increases which increases the common emitter current, resulting in an increase of voltage drop across  $R_E$ .

This means that the emitters of both transistors are driven towards positive which in turn implies that the base Of  $Q_2$  would Start to become more and more negative. This results in a

decrease of collector current, IC2 which in turn decreases the voltage drop across the collector resistor RC2, resulting in an increase in the output voltage V02. This indicates that the changes in the sinusoidal signal observed at the input or transistor Q1 is reflected as such across the collector terminal Of Q2 and appear with a phase difference of 180° across the collector Type here to search terminal of Q1. The differential amplification can be driven by considering the output in-between the collector terminals of the transistors, Q1 and. On the Other hand, if the signal applied to each input terminal is equal in amplitude and is in the same phase (called the common mode input signal), the change in current flow through both transistors will be identical, the bridge will remain balanced, and the voltage between the output terminals will remain zero. Thus, the circuit provides high gain for differential mode signals and no output for all common mode signals. The ability of the amplifier to reject these common voltages on its two input leads is known as

common-mode rejection and is specified as the ratio of common-mode input to differential input to elicit the same response. It is abbreviated as CMRR (Common-mode rejection ratio). CMRR is an important specification referred to the differential amplifier and is normally expressed as decibels. CMRR of the preamplifiers should be as high as possible so that only the wanted signals find a way through the amplifier and all unwanted signals get rejected in the preamplifier stage.

**Op-amp Differential Amplifier:**

The design of a good differential amplifier essentially implies the use of closely matched components. Which has been best achieved in the integrated circuit form. High gain integrated dc amplifiers, with differential input connections and a provision for external feedback have been given the name operational amplifiers because of their ability to perform mathematical operations.

These amplifiers are applied for the construction of ac or dc amplifiers, active filters, phase inverters, multivibrators and comparators, etc. by suitable feedback arrangement, and therefore find a large number of applications in the medical field.

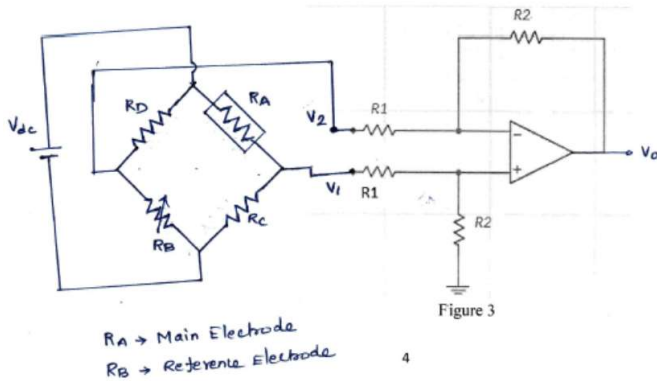

Input V1=0, the circuit act as an inverting amplifier. So, the output of inverting amplifier

$$V_{01} = -\frac{R_2}{R_1} V_1$$

If the input V1=0, the circuit act as a Non inverting amplifier. The voltage at the non-inverting terminal

$$V_N = V_2 \frac{R_2}{R_1 + R_2}$$

The non-inverting amplifier output is

$$V_{02} = \left(1 + \frac{R_2}{R_1}\right) V_N$$

The total output voltage of differential amplifier,

$$V_0 = V_{01} + V_{02}$$

$$V_0 = -\frac{R_2}{R_1} V_1 + \left(1 + \frac{R_2}{R_1}\right) V_2$$

$$V_0 = -\frac{R_2}{R_1} V_1 + \left(1 + \frac{R_2}{R_1}\right) V_2 \frac{R_2}{R_1 + R_2}$$

$$V_0 = \frac{R_2}{R_1} (V_1 - V_2)$$

The common mode rejection for most op-amps is typically between 60 dB and 90 dB. This may not be sufficient to reject common mode noise generally encountered in biomedical measurements. Also, the input impedance is not very high to handle signals from high impedance sources. One method to increase the input impedance of the op-amp is to use field effect transistors (FET) in the input differential stage. A more common approach is to use an instrumentation amplifier in the preamplifier stage

### **Chopper Amplifier**

When recording biopotentials noise and drift are the two problems encountered. Noise is due to the recording device and by the patient when they move. Drift is a shift in baseline created due to various thermal effects. A DC amplifier has a shift or sudden peak in the output when the input is zero. Therefore, a chopper amplifier solves the problems of drift in DC amplifiers. The name Chop means to sample the data. The amplifier circuit samples the analog signal. So, it is known as **chopper amplifier**. The first block chopper accepts the DC input signal and converts them to an AC signal. The AC amplifier block amplifies the chopped AC signal. Next, in the demodulator rectifier block, an amplified chopped AC signal is converted to amplified DC signal.

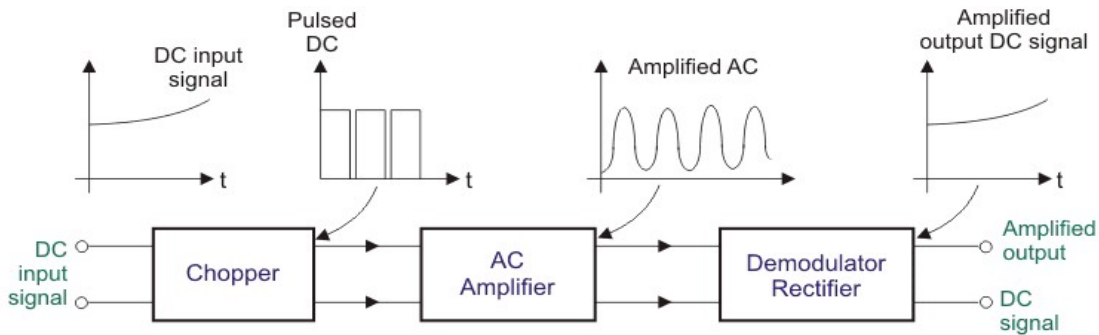

Schematic Diagram of a Chopper Amplifier

Chopper amplifier is classified into two types. Mechanical and non-mechanical choppers. The chopper converts DC or low-frequency signal to high-frequency signal. An AC amplifier amplifies the modulated high-frequency signal. The amplified signal is demodulated and filtered to obtain the low frequency or DC signal.

### **Mechanical Chopper Amplifier**

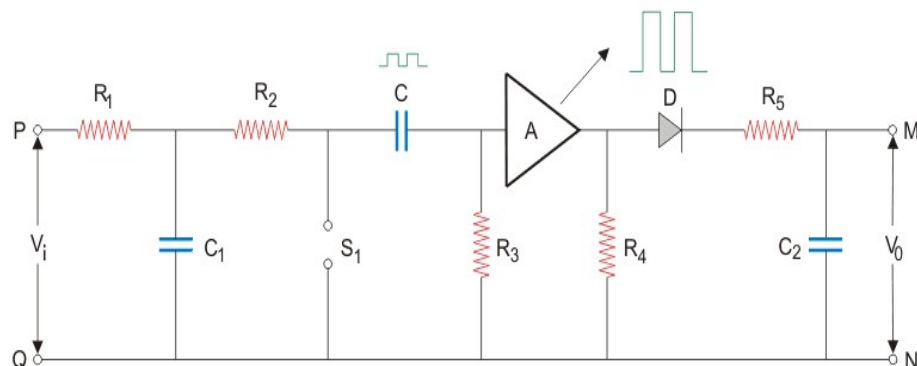

Here, chopper  $S_1$  acts as electromagnetically operated switch or relay. 'A' is the AC amplifier that has

an input terminal and a ground terminal. 'Q' acts as reference term. Chopper acts a switch, so it connects the amplifier input terminal alternatively to reference term Q. Consider a condition in which chopper  $S_1$  is closed. At this position, the amplifier input terminal connects to  $Q_1$ . The entire circuit is short-circuited, so input voltage is zero. Now, let us consider the reverse operation when chopper  $S_1$  is open. The AC amplifier starts receiving the signal from P terminal. Finally, the amplifier input has an alternating voltage that varies between zero and input voltage. At this stage, conversion of DC signal to square wave pulse occurs with amplification. Diode 'D' rectifies the chopped signal. After rectification, the rectified signal is filtered and amplified. At the output terminal M and N, the amplified DC output signal occurs. Chopping or sampling rate determines the chopper response time.

### Non-Mechanical Chopper Amplifier

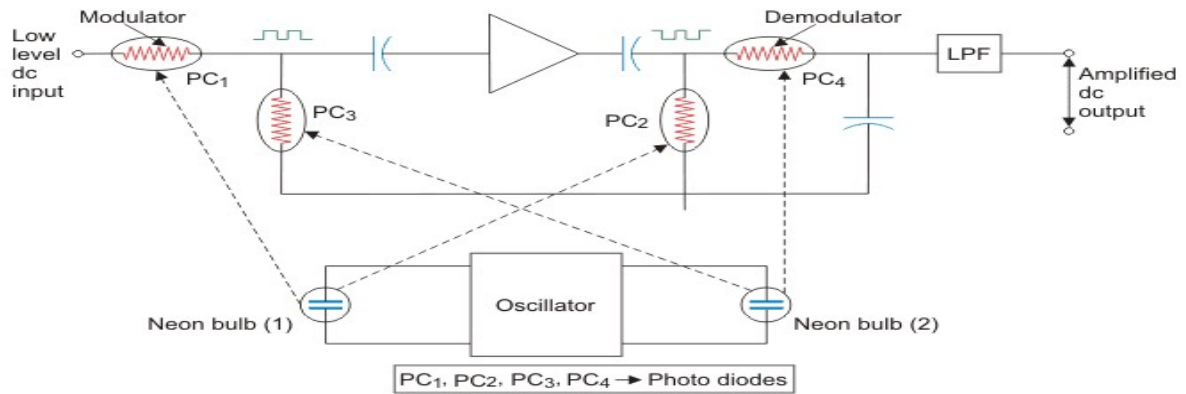

In comparison with mechanical type, a **non-mechanical chopper** uses photodiodes or photoconductors for modulation (convert DC signals to AC signals) and demodulation (convert AC signals to DC signals). When light is not incident on the photodiode, no current flows through the circuit. However, when light falls on the photosensor, the resistance becomes low. So, the current flows through the sensor. This system is similar to a switching operation.

From the figure, an oscillator has two neon bulbs, which operates on half cycles of oscillation.  $PC_1$ ,  $PC_2$ ,  $PC_3$ , and  $PC_4$  are photodiodes. Neon lamp 1 flashes light on  $PC_1$  and  $PC_2$ . Neon lamp 2 flashes light on  $PC_3$  and  $PC_4$ . When light falls on  $PC_1$ , its resistance value reduces making the capacitor to charge. Light falls on  $PC_3$  making the input to flow through it when there is no light on  $PC_1$ . Therefore, the light incidence on  $PC_1$  and  $PC_3$  takes place alternatively to generate a square wave pulse across the output capacitor. The generated square wave pulse is the input for the AC amplifier. The amplifier output is an amplified square wave pulse. The other two photodiodes  $PC_2$  and  $PC_4$  are in the output circuit. It recovers DC signal and makes the capacitor fully charged to the peak value of output voltage. At the final stage, a low pass filter removes the unwanted noise and ripples. The output is an amplified DC signal.

### Differential Chopper Amplifier

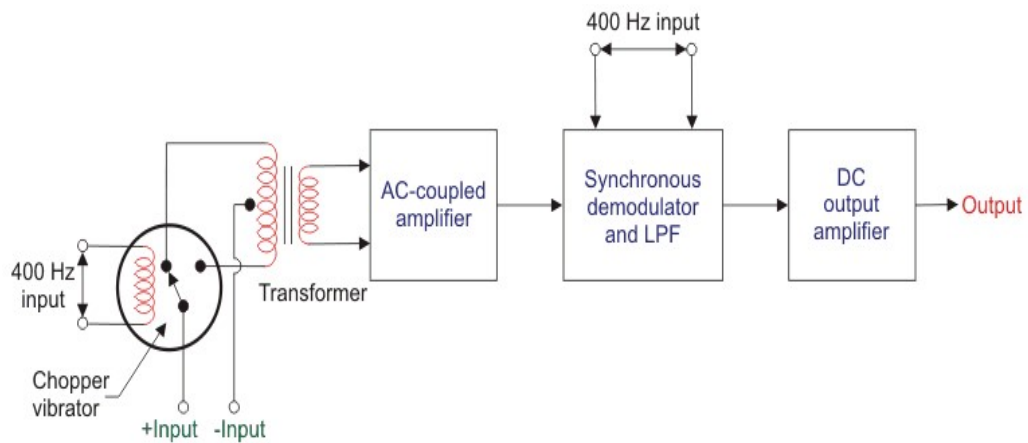

A type of chopper used for EEG measurement is a differential chopper. It has a transformer. A chopper vibrator connects the input of the transformer. The center tap of the transformer acts as one of the terminals for the input connector. The chopper switch acts as another terminal. AC coupled amplifier provides the gain. The output from this amplifier goes to filter and demodulator block. Finally, an amplified DC output signal is obtained.

**Isolation Amplifier**

Isolation amplifiers are known as Pre-amplifier isolation circuits. An isolation amplifier increases the input impedance of a patient monitoring system. It also helps to isolate the patient from the device. Using the isolation amplifier prevents accidental internal cardiac shock. It provides up to 1012 Ω insulation between the patient and the power line in the hospital.

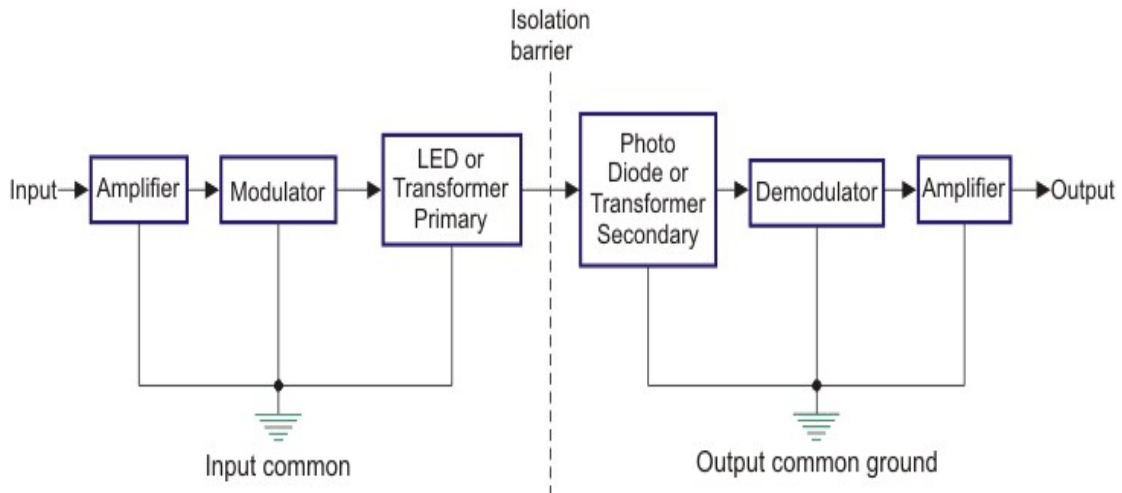

**Block Diagram of Isolation Amplifier**

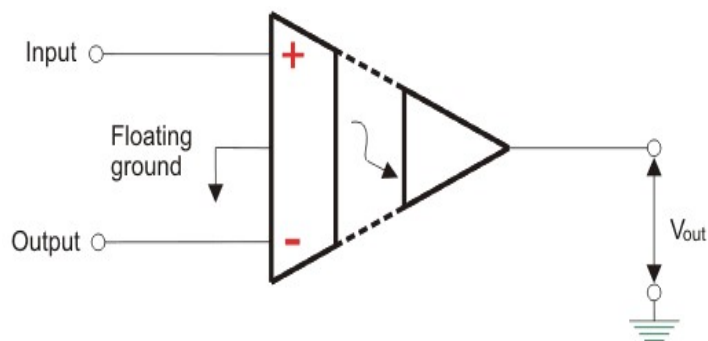

**Symbol of Isolation Amplifier**

The electrical signals are obtained with electrodes. The signals received goes to the amplifier block, where signals amplification occurs. After amplification, the signal enters the modulation block. When either it goes to the isolation barrier, optical cable or transformer can be used. If in case of optical cable, modulator output travels to LED. The LED converts electrical signals into light energy. If the transformer acts an isolation barrier, modulator output connects the primary winding of the transformer. Energy from primary transfers to the secondary winding based on the mutual induction principle. At the next stage, secondary output enters the demodulation block. Finally, the amplified demodulated signal is obtained.

### ECG Isolation Amplifier

During ECG measurement, signals generated from all leads are sent to the low pass filter. This filter is named as Electro surgery filters because it decreases the interference between electrosurgery and radio frequency. Next block is the high voltage and overvoltage protection that can withstand large voltage during defibrillation.

It goes to Lead Selector Switch block, which selects the required configuration. Lead selection output goes to the DC amplifier. We have a transformer, whose primary winding is connected to the oscillator and secondary to rectifier and filter. ECG signal is modulated with the Synchronous modulator. The second transformer delivers the output from the synchronous modulator to the synchronous demodulator. The output from the demodulator is fed as input to the power amplifier.

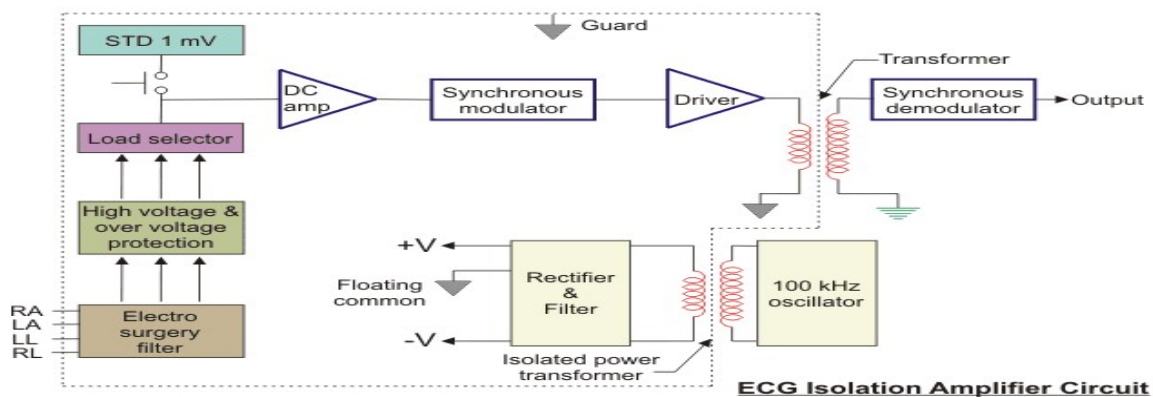

### ECG

- An ECG, also sometimes referred to as an EKG from the original German word 'electrocardiogram', measures the electrical activity of the heart. This electrical activity produces the contractions and relaxations of the cardiac muscles required to pump blood around the body.
- An ECG is recorded over a series of cardiac cycles (heartbeats) and shows the different phases of the cardiac cycle.
- The ECG indirectly measures transmembrane voltages in myocardial cells that depolarize and repolarize within each cardiac cycle. These depolarizations and repolarization events produce ionic currents within the body, and these are transduced into voltages by electrodes placed on the surface of the chest and thorax. Up to twelve different lead voltages are recorded, with the magnitude of the voltages being in the low mV range, and a frequency spectrum between 0 and 30 Hz.
- The ECG signal has many distinct features, such as the P-wave, QRS-complex and T-wave. The amplitude, shape and relative timing of these features can be used to diagnose different clinical conditions.
- An ECG is an essential part of diagnosing and treating patients with acute coronary syndromes and is the most accurate method of diagnosing ventricular conduction disturbances and cardiac arrhythmias.



- It is also used to diagnose heart conditions such as myocardial infarcts, atrial enlargements, ventricular hypertrophies and blocks of the various bundle branches. An ECG is universally used to monitor a patient's cardiac activity during surgery.
- Most ECG machines are now digital and automated, meaning that the data is analysed automatically. Software algorithms measure different aspects (such as delays, durations and slopes) of the ECG waveform and provide a set of keyword interpretations of the scan such as 'abnormal ECG' or more specific suggested diagnoses such as 'possible sinoatrial malfunction'

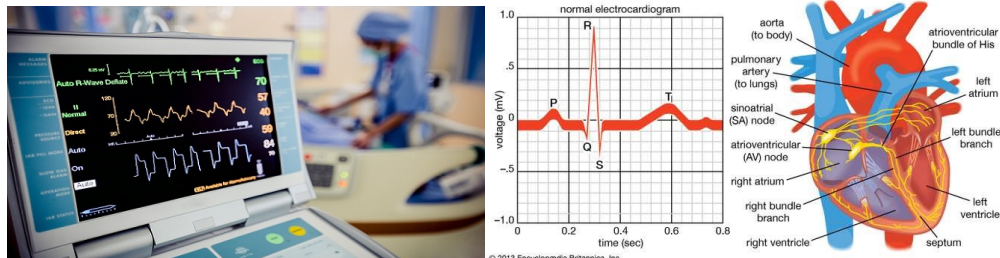

### Block diagram Description of an Electrocardiograph

The potentials picked up by the patient electrodes are taken to the lead selector switch. In the lead selector, the electrodes are selected two by two according to the lead program.

By means of capacitive coupling, the signal is connected symmetrically to the long-tail pair differential preamplifier.

The preamplifier is usually a three or four stage differential amplifier having a sufficiently large negative current feedback, from the end stage to the first stage, which gives a stabilizing effect.

The amplified output signal is picked up single-ended and is given to the power amplifier.

The power amplifier is generally of the push-pull differential type. The base of one input transistor of this amplifier is driven by the preamplifier unsymmetrical signal. The base of the other transistor is driven by the feedback signal resulting from the pen position and connected via frequency selective network.

The output of the power amplifier is single-ended and is fed to the pen motor, which deflects the writing arm on the paper. A direct writing recorder is usually adequate since the ECG signal of interest has limited bandwidth. Frequency selective network is an R-C network, which provides necessary damping of the pen motor and is pre-set by the manufacturer.

The auxiliary circuits provide a 1 mV calibration signal and automatic blocking of the amplifier during a change in the position of the lead switch. It may include a speed control circuit for the chart drive motor.

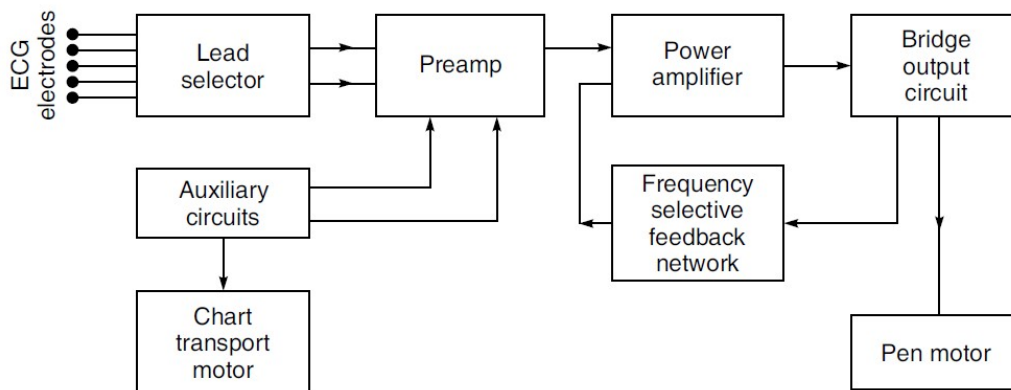

A 'standby' mode of operation is generally provided on the electrocardiograph. In this mode, the stylus moves in response to input signals, but the paper is stationary. This mode allows the operator to adjust the gain and baseline position controls without wasting paper.

Electrocardiograms are almost invariably recorded on graph paper with horizontal and vertical lines at 1 mm intervals with a thicker line at 5 mm intervals. Time measurements and heart rate measurements are made horizontally on the electrocardiogram.

**Isolated Pre-amplifier:** It had been traditional for all electrocardiographs to have the right leg (RL) electrode connected to the chassis, and from there to the ground. This provided a ready path for any ground seeking current through the patient and presented an electrical hazard. As the micro shock hazard became better understood, particularly when intracardiac catheters are employed, the necessity of isolating the patient from the ground was stressed.

Block diagram of an isolation preamplifier used in modern electrocardiographs.

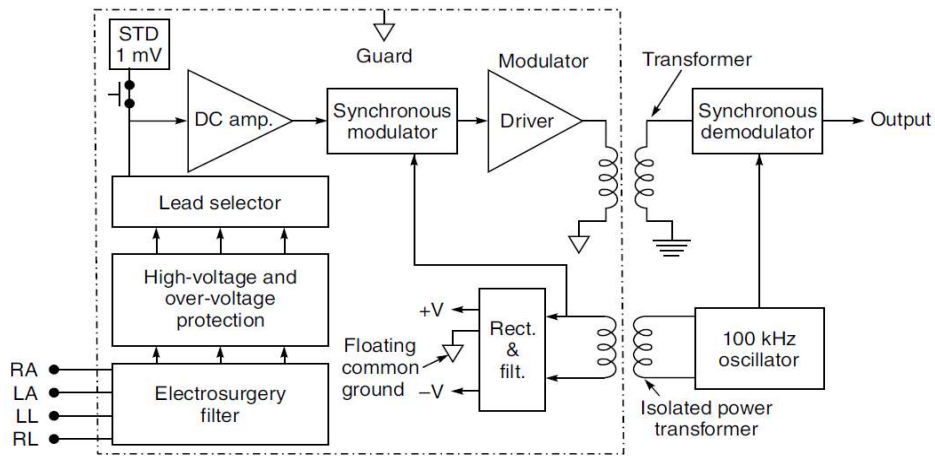

Different signals obtained from the right arm (RA), left arm (LA) and right leg (RL) are given to a low-pass filter. Filtering is required on the input leads to reduce interference caused by electro surgery and radio frequency emissions and sometimes from the 50 kHz current used for respiration detection. The filter usually has a cut off frequency higher than 10 kHz. A multistage filter is needed to achieve a suitable reduction in high frequency signal.

**Block diagram of an isolation preamplifier (transformed-coupled) commonly used in modern ECG machines**

**The ECG Leads**

Two electrodes placed over different areas of the heart and connected to the galvanometer will pick up the electrical currents resulting from the potential difference between them. For example, if under one electrode a wave of 1 mV and under the second electrode a wave of 0.2mV occurs at the same time, then the two electrodes will record the difference between them. The resulting tracing of voltage difference at any two sites due to electrical activity of the heart is called a "LEAD"

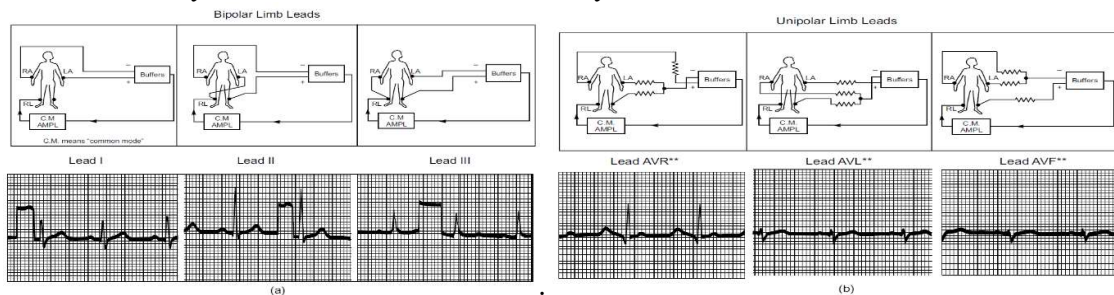

Types of lead connections with typical ECG waveforms: (a) bipolar limb leads (b) unipolar

The electrocardiogram is of greatest use in diagnosing cardiac arrhythmias, acute and prior myocardial infarctions (heart attacks), pericardial disease, and cardiac enlargement (atrial and

The presence of hypertension (high blood pressure), thyroid disease, and certain types of malnutrition also may be revealed by an electrocardiogram. In addition, electrocardiography can be used to determine whether a slow heart rate is physiological or is caused by heart block.

### **ELECTROENCEPHALOGRAPH (EEG)**

- Electroencephalograph is an instrument for recording the electrical activity of the brain, by suitably placing surface electrodes on the scalp. EEG, describing the general function of the brain activity, is the superimposed wave of neuron potentials operating in a non-synchronized manner in the physical sense. Its stochastic nature originates just from this, and the prominent signal groups can be empirically connected to diagnostic conclusions.
- Monitoring the electroencephalogram has proven to be an effective method of diagnosing many neurological illnesses and diseases, such as epilepsy, tumour, cerebrovascular lesions, ischemia and problems associated with trauma. It is also effectively used in the operating room to facilitate anaesthetics and to establish the integrity of the anaesthetized patient's nervous system. This has become possible with the advent of small, computer-based EEG analysers.
- EEG may be recorded by picking up the voltage difference between an active electrode on the scalp with respect to a reference electrode on the ear lobe or any other part of the body. This type of recording is called 'monopolar' recording. However, 'bipolar' recording is more popular wherein the voltage difference between two scalp electrodes is recorded. Such recordings are done with multi-channel electroencephalographs.
- EEG signals picked up by the surface electrodes are usually small as compared with the ECG signals. They may be several hundred microvolts, but 50 microvolts peak-to-peak is the most typical. The brain waves, unlike the electrical activity of the heart, do not represent the same pattern over and over again. Therefore, brain recordings are made over a much longer interval of time in order to be able to detect any kind of abnormalities.
- Selecting the proper filter band (band width must be at least 0.5 Hz–70 Hz) is important to acquire proper signal. This is important for digitizing and data storing. Sufficient and optimum sampling rate (140 Hz) should be adopted.
- EEG electrodes are smaller in size than ECG electrodes. They may be applied separately to the scalp or may be mounted in special bands, which can be placed on the patient's head. In either case, electrode jelly or paste is used to improve the electrical contact. If the electrodes are intended to be used under the skin of the scalp, needle electrodes are used. They offer the advantage of reducing movement artefacts. EEG electrodes give high skin contact impedance as compared to ECG electrodes. Good electrode impedance should be generally below 5 kilohms.
- Impedance between a pair of electrodes must also be balanced or the difference between them should be less than 2 kilohms. EEG preamplifiers are generally designed to have a very high value of input impedance to take care of high electrode impedance.
- In today's technology, high input impedance (1 G) amplifier chips and active electrode approaches decrease dependency of the contact impedance. To acquire proper signal, electrodes should not be moved. Otherwise, it causes fluctuation of the EEG signal, and spikes on it.
- Noise reduction techniques must be considered in electronic circuitry and printed circuit board design. Electronic cards and connection cables should be placed in a metal box to reduce electronic noise as much as possible. Using twisted, braided, and driven signal cables gives good results. Because EEG signals are of low amplitude, they are very sensitive to electronic noise.
- Electronic noise should be less than 2  $\mu$ V (peak-to-peak).

### **Block Diagram Description of Electroencephalograph**

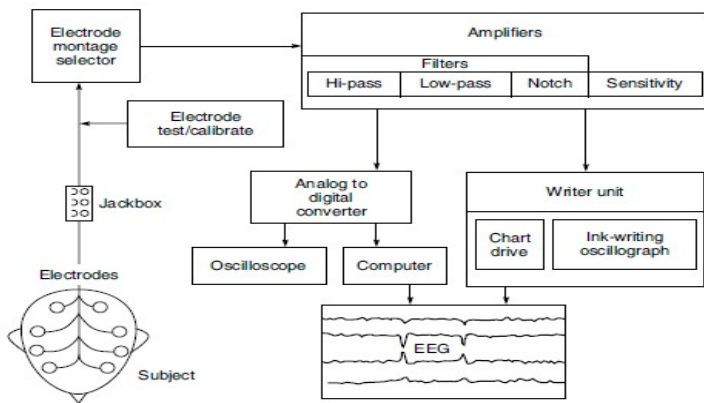

► Fig. 5.17 Schematic diagram of EEG machine (after Isley et al., 1998)

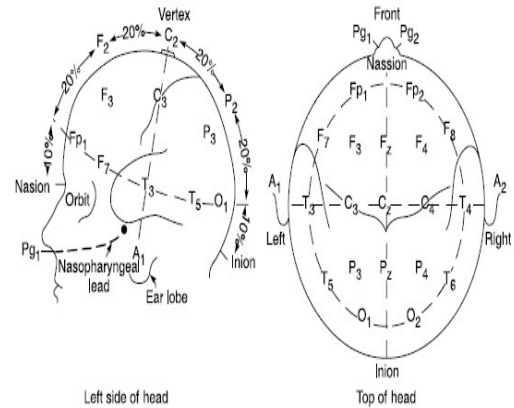

► Fig. 5.18 10-20 System of placement of electrodes

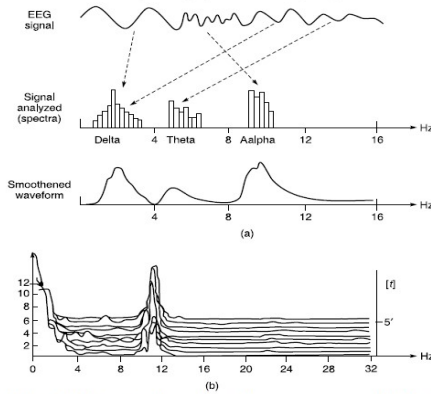

► Fig. 5.19 (a) Typical EEG waveform broken down into frequency components (b) Mathematical and display techniques used to generate the compressed spectral array format

## EEG Uses

EEGs are used to diagnose conditions like:

- Brain tumors
- Brain damage from a head injury
- Brain dysfunction from various causes (encephalopathy)
- Inflammation of the brain (encephalitis)
- Seizure disorders including epilepsy
- Sleep disorders
- Stroke

An EEG may also be used to determine if someone in a coma has died or to find the right level of anesthesia for someone in a coma.

## ELECTROMYOGRAPH(EMG)

- Electromyograph is an instrument used for recording the electrical activity of the muscles to determine whether the muscle is contracting or not; or for displaying the action potentials spontaneously present in a muscle in visual and audible form or those induced by voluntary contractions as a means of detecting the nature and location of motor unit lesions; or for recording the electrical activity evoked in a muscle by the stimulation of its nerve.
- The instrument is useful for making a study of several aspects of neuromuscular function, neuromuscular condition, extent of nerve lesion, reflex responses etc.
- EMG measurements are also important for the myoelectric control of prosthetic devices (artificial limbs). This use involves picking up EMG signals from the muscles at the terminated nerve endings of the remaining limb and using the signals to activate a mechanical arm. This is the most demanding requirement from an EMG since on it depends the working of the prosthetic device.

- EMG is usually recorded by using surface electrodes or more often by using needle electrodes, which are inserted directly into the muscle. The surface electrodes may be disposable, adhesive types or the ones which can be used repeatedly.
- A ground electrode is necessary for providing a common reference for measurement. These electrodes pick up the potentials produced by the contracting muscle fibres. The signal can then be amplified and displayed on the screen of a cathode ray tube. It is also applied to an audio-amplifier connected to a loudspeaker. A trained EMG interpreter can diagnose various muscular disorders by listening to the sounds produced when the muscle potentials are fed to the loudspeaker. The stages of data acquisition and signal processing in an electromyograph.
- The myoelectric signals are amplified with the use of preamplifiers and a differential amplifier together having an effective passband of 10 to 1,000 Hz. The signals are sampled at 5 kHz with 16-bit analog-to-digital conversion, rectified, and smoothed with a running time window average with a window length of 240 ms that is updated every 80 ms.
- The processed signals are normalized by the amplitudes of the maximum voluntary contractions and are displayed on a computer monitor. The waveforms can be stored to facilitate playback and study of the EMG waveforms at a later convenient time. The waveform can also be printed as a hard copy for records.

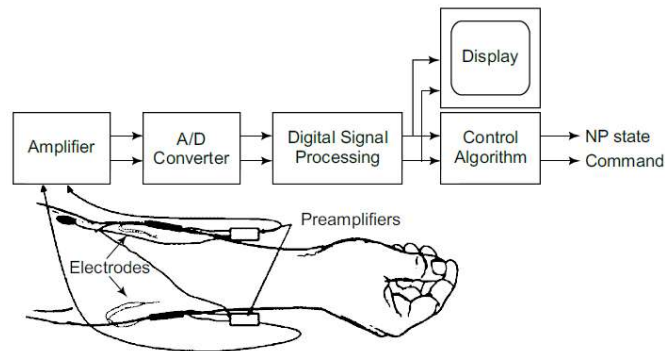

► Fig. 5.20 Block diagram of a typical set-up for EMG recording

- Modern day EMG machines invariably use digital signal processing techniques.
- Analog- to- digital converters (ADC) are used to convert the amplified differential signals into digital signals that are further processed by a microprocessor or a PC. The quality of an EMG signal is therefore largely dependent on the resolution, accuracy and sampling rate of the ADC used.



► Fig. 5.21 PC based digital EMG recording system

- Modern EMG machines are PC based available both in console as well as laptop models. They provide full colour waveform display, automatic cursors for marking and making measurements and a keyboard for access to convenient and important test controls.
- The system usually incorporates facilities for recording of the EMG and evoked potentials. The stimulators are software controlled. For report generation in the hard copy form, popular laser printers can be used.
- EMG equipment to have a range of new features and networking capabilities.
- The RS-232 serial data transfer protocol previously used in the PC-based systems is now replaced by the Universal Serial Bus 2.0 which provides faster data exchange rates and even means of supplying power to the EMG handheld device to recharge the device.



- Increased storage capacity of data recordings on digital storage media has become a common place.
- EMG equipment to provide the user with extended mobility from the PC on PC-based systems. Acquired EMG signals can now be picked up on the body and sent wirelessly to a PC where it is recorded, processed and analysed.

**Electroretinography (ERG)**

- An electrical potential exists between the cornea and the back of the eye. These potential changes when the eye is illuminated. The process of recording the change in potential when light falls on the eye is called electroretinography.
- ERG potentials can be recorded with a pair of electrodes. One of the electrodes is mounted on a contact lens and is in direct contact with the cornea.
- The other electrode is placed on the skin adjacent to the outer corner of the eye.
- A reference electrode may be placed on the forehead. A general-purpose direct writing recorder may be used for recording electroretinograms. The magnitude of the ERG voltage depends upon the intensity and duration of the light falling on the eye.

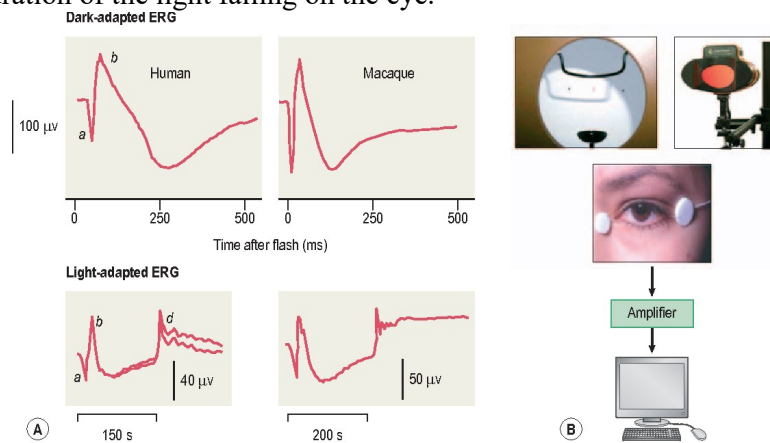

**Types of ERG Measurement**

- Focal ERG (fERG)
- Multifocal ERG (mfERG)

## Testing of ERG

- ERG is one type of ophthalmic **electrophysiology test**. Depending on which eye condition is being studied, ERG may be performed in conjunction with other tests, such as electrooculography (EOG) or dark adaptometry testing.
- ERG is usually well tolerated, painless, and medical professionals can perform ERG even in cooperative children and infants. Occasionally, sedation may be necessary.
- The patient assumes a comfortable position either lying down or sitting up.
- An eye doctor dilates the patient's eyes with standard dilating eyedrops. Anesthetic drops are also given. The doctor then props the eyelids open with a speculum and gently places a contact lens electrode or an electrode resembling a fine thread on each eye. The physician places an additional electrode on the forehead skin.
- During an ERG recording session, the patient looks into a bowl displaying different amounts of light. Retinal cells emit small electrical signals when stimulated by certain types of light. The ERG machine records the resulting electric signals' amplitude (voltage) and time course.
- The visual stimuli vary; some are done with no light in the background (dark-adapted, or scotopic readings), and some are done with light in the background (light-adapted, or photopic readings). The light stimuli include flashes of light (flash ERG) and flickering lights.

## Multifocal ERG

While a standard ERG detects activity of the entire retina, the multifocal ERG tests different areas of the retina, looking for localized areas of abnormality. This test takes longer than a standard ERG.

## Normal ERG Results

A normal ERG shows an a-wave (photoreceptor activity) and b-wave (Muller and bipolar cells activity) patterns in dark-adapted (scotopic) and light-adapted (photopic) settings. Wave patterns that are diminished in size or delayed or prolonged in time provide clues about the types of damaged cells.

## Abnormal ERG results

Abnormal ERG results provide clues as to which specific retinal cells are affected by disease. There are retinal diseases in which specific cells are missing or weak at birth, while other abnormalities are acquired over time.

## Lead Systems

To record ECG 12 electrodes connected to the body of the patient. Electrodes connected to ECG machine using wires called leads. Leads are electrodes which measure the difference in electrical potential between either:

1. Two different points on the body (bipolar leads)
2. One point on the body and a virtual reference point with zero electrical potential, located in the center of the heart (unipolar leads).

## Classification

1. Standard Limb Leads or Bipolar Leads or Einthoven Leads: I, II & III
2. Augmented Limb Leads (Unipolar): aVR, aVL & aVF
3. Precordial Leads: V1- V6

## Standard Limb Lead or Bipolar Limb leads– Standard Lead I, Lead II and Lead III

The Standard Limb Leads are used to display a graph of the potential difference recorded between two limbs at a time. In these leads, one limb carries a positive electrode and the other limb, a negative one.

The three limb electrodes, I, II and III form a triangle (**Einthoven's Equilateral Triangle**), at the right arm (RA), left arm (LA) and left leg (LL).



LEAD	Positive Electrode	Negative Electrode
I	LA	RA
II	LL	RA
III	LL	LA

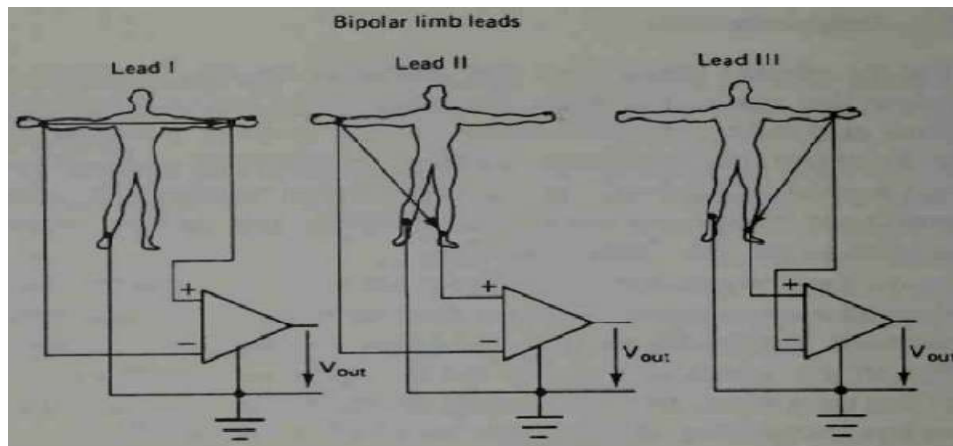

- **Lead I** has a positive electrode on the left arm and a negative electrode on the right arm. Lead I is a bipolar, indirect lead.
- **Lead II** has a positive electrode on the right arm and a negative electrode on the left foot. Lead II is a bipolar, indirect lead.
- **Lead III** has a *positive* pole on the left *foot* and a negative pole on the left hand. Lead III is a bipolar, indirect lead.

### Einthoven's Equilateral Triangle

The three limb electrodes, I, II and III form a triangle (**Einthoven's Equilateral Triangle**), at the right arm (RA), left arm (LA) and left leg (LL).

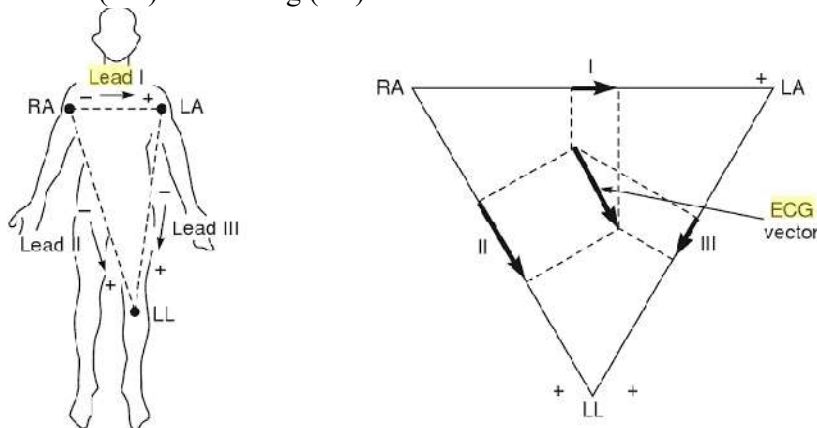

- In defining time bipolar leads, Einthoven postulate that at any given instant of the cardiac cycle, the electrical axis of the heart can be represented as a two-dimensional vector.
- The ECG measured from any of the three basic limb leads is a time-variant single-dimensional component of the vector.
- He proposed that the electric field of the heart could be represented diagrammatically as a triangle, with the heart ideally located at the centre. The triangle, known as the "Einthoven triangle". The sides of the triangle represent the lines along which the three projections of the ECG vector are measured.

- It was shown that the instantaneous voltage measured from any one of the three limb lead positions is approximately equal to the algebraic sum of the other two or that the vector sum of the projections on all three lines is equal to zero.
- The I-wave is positive and in all the bipolar lead positions, QRS of a normal heart is greatest in lead II.

### Augmented Limb Leads (Unipolar: aVR, aVL, aVF)

Limb leads In unipolar limb leads two of the limb leads are tied together and recorded with respect to the third limb. In the lead identified as aVR, the right arm is recorded with respect to a reference established by joining the left arm and left leg electrodes. In the aVL lead, the left arm is recorded with respect to the common junction of the right arm and left leg. In the aVF lead, the left leg is recorded with respect to the two arm electrodes tied together. They are also called augmented leads or 'averaging leads'. The resistances inserted between the electrodes-machine connections are known as 'averaging resistances'.

LEAD	Positive Electrode
aVR	RA
aVL	LA
aVF	LL

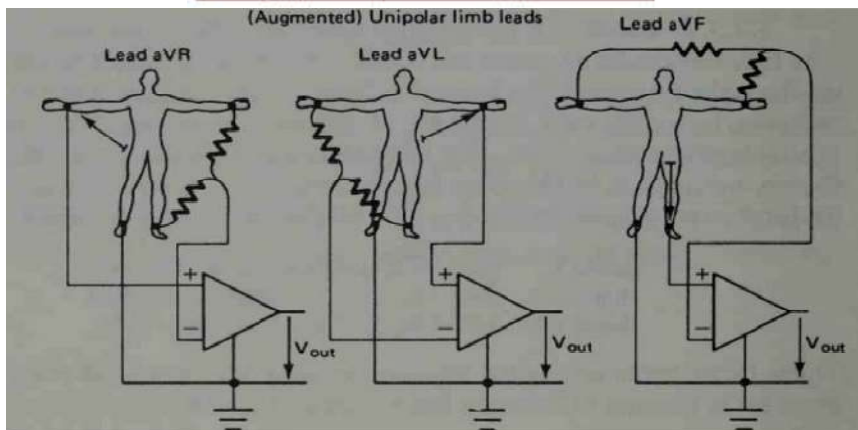

### Precordial Leads: V1- V6

Precordial leads the second type of unipolar lead is a precordial lead. It employs an exploring electrode to record the potential of the heart action on the chest at six different positions. These leads are designated by the capital letter 'V' followed by a subscript numeral, the positions of which represents the position of the electrode on the pericardium chest leads are shown

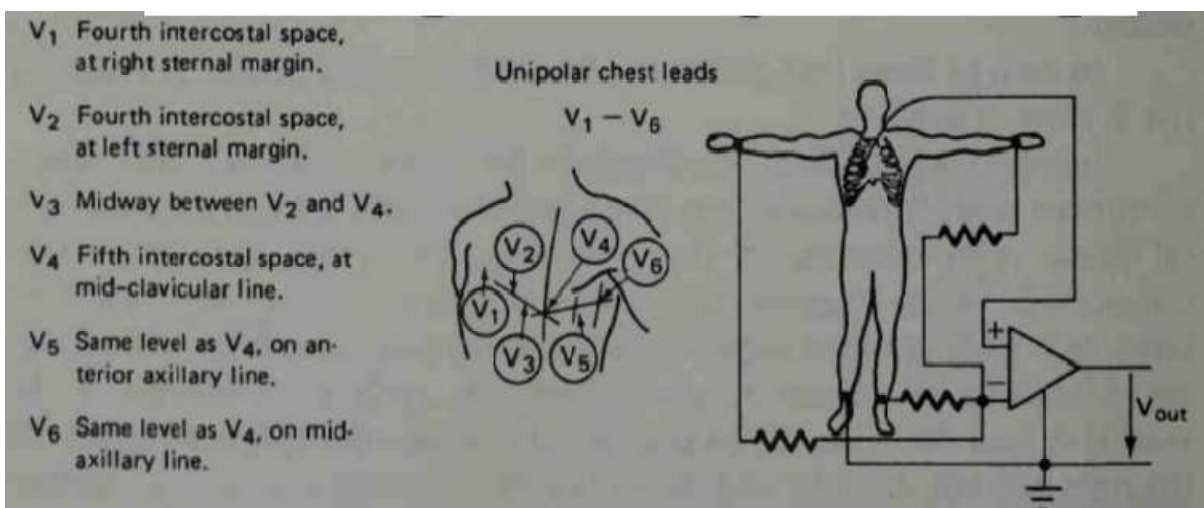

## Recorder Methods

The recorder is required in any instrumentation system to record data which has been acquired. Data can be in analog or digital form hence the 2 types of recorders namely:

- Analog recorder
- Digital recorder

Analog recorders can be:

- Graphic
- Oscillographic
- Magnetic tape recorder

The graphic recorder is a device which records some physical event on chart paper with stylus as tracing which is the variation of input signal along time on moving chart paper.

**Digital recorders** use a linear fixed array of small recording elements under which the paper moves. This is in contrast with the conventional recorders that use a moving pen or stylus. The stylus in the digital recorder is a large number of fixed styli, each one of which corresponds to one amplitude of signal to be recorded. Signals are thus reproduced as discrete values at discrete times. Analog as well as digital signals can be processed. In the case with analog signals, sampling and digitization are part of the recording process.

## **Strip Chart Recorder**

A strip chart recorder consists of:

- A long strip of chart paper which can move vertically
- A drive system to move the chart paper at some selected speed
- A stylus for making trace on the moving chart paper
- Stylus drive system to move the stylus horizontally on a moving chart paper or in proportion to the quantity or input to be recorded.
- A range selector switch to limit the horizontal move of the stylus

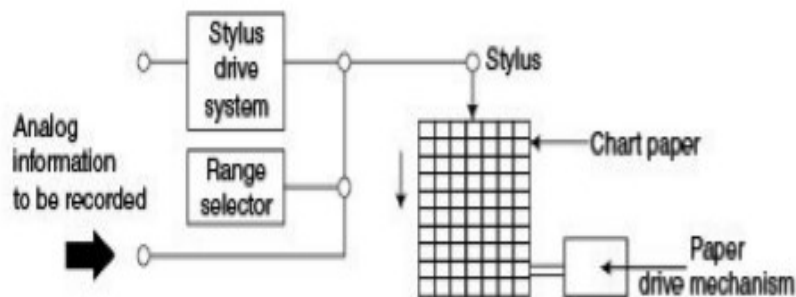

An electronic stepper motor or synchronous motor or a spring wound mechanism is used for driving the strip chart paper. There are many ways to move the stylus to make the marks on the paper. The marking can be done with:

- Ink filled stylus
- Heated stylus
- Chopper bars
- Electric stylus marking
- Optical marking

An **Ink filled stylus** contains a capillary connection between the pen (stylus) and ink reservoir. This type of stylus is unsuitable at high speed and it also develops clogging of ink when the stylus is set. The **heated stylus** melts a thin coating of white wax on a black recording paper while working. In a **chopper bar**, the stylus marks on a paper with special coating which is sensitive to current. The **optical stylus** uses a beam of light to write on a photosensitive paper.

## Galvanometric Recorder

The principle of working of galvanometric recorder is that when a current flow as per the input signal through the coil kept in a strong magnetic field, the coil with the pen or stylus deflects proportionally to the input quantity as shown in the diagram below:

There are 3 forces which act on the moving system i.e.

- The deflecting force which results from the current flowing in the coil.
- The controlling force as applied by the spring action to control the limit of deflection.
- Damping force to bring the pen or stylus to rest as quickly as possible.

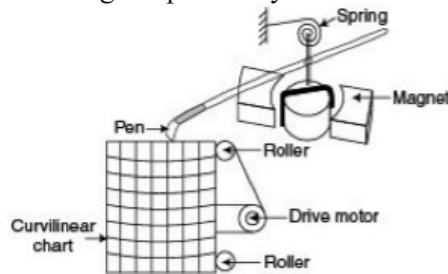

### Galvanometric recorder system

The chart paper is driven at a constant speed by an electric or stepper motor. The ink recording method is widely used in which pen or stylus marks on the moving chart paper. The demerits of a galvanometric recorder include:

- A low input impedance
- limited sensitivity

## Ultraviolet Recorder

Ultraviolet recorder can record events or physiological signals with frequencies in the range of zero to several kHz. Note, galvanometric and potentiometric recorders are unsuitable when the signal has high frequencies.

The ultraviolet recorder consists of a number of moving coils mounted in a single magnet block

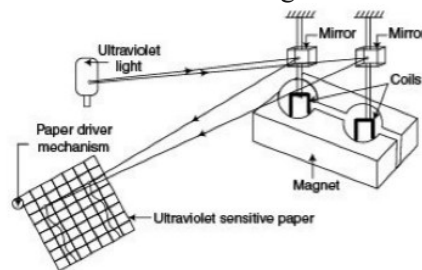

### Ultraviolet Recorder

- A silvered mirror is attached to each galvanometer coil. A paper sensitive to ultraviolet light is used for producing a trace for the purpose of recording.
- The ultraviolet light is projected on this paper with the help of the mirror attached to each coil. The coil is deflected if any current flows through the coil as coils are subjected to magnetic field.
- The ultraviolet light is also deflected by the mirror in proportion to the deflection of coil. As the current flow in the coil depends upon physiological inputs, hence the deflection of the ultraviolet light through mirror is in proportion to physiological inputs.
- The moving ultraviolet light falling on the moving light sensitive paper forms a trace of variation of input signal on the paper.
- The trace of variation on the paper is the record of the variation of input signal with time. The ultraviolet recorder may be single channel or multichannel. After recording, the ultraviolet sensitive paper has to be chemically treated before any storage

## Inkjet Recorder

The principle of working of Inkjet recorder is that a very fine Inkjet is made to move on the paper per the physiological events or signals.

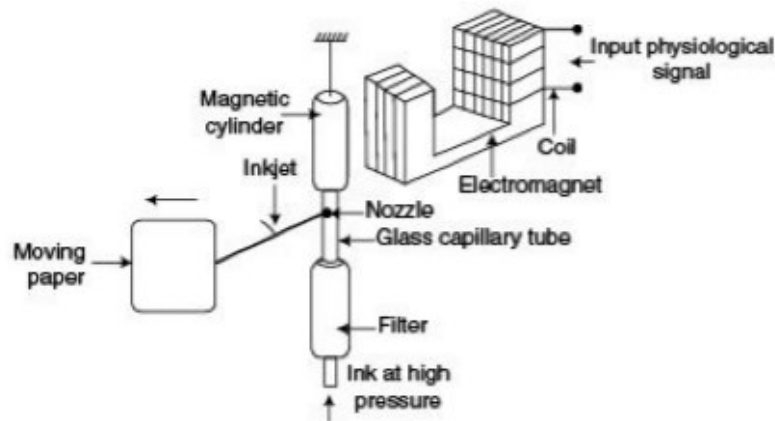

- The recorder has a glass capillary tube placed between the poles of an electromagnet. The coil of the electromagnet is connected to the amplified physiological signals. A small cylindrical magnet is attached to this ink capillary tube.
- The variation of current corresponding to physiological signals in the electromagnetic coil produce a varying magnetic field in it which interacts with the field of the cylindrical magnet attached to the capillary.
- The interaction of the magnetic field deflects the cylindrical magnet and the capillary tube attached with it as per the strength of the physiological signals.
- The capillary tube is supplied with ink at high pressure, and the ink comes out of the nozzle provided on the capillary tube in the form of a jet. The waveform is traced on the paper.
- Using more capillaries of different colours, the inkjet recorder can work as a multichannel recorder. The inkjet uses normal paper. As it does not have any stylus it can work at much high frequencies.

### **Electrical safety in medical environment**

- Electrical Safety is one of the basic protection mechanisms for patient, operator, and third persons.
- Medical technology has improved health care in ALL medical specialties, with rising complexity
- Hospitals are confronted with the difficult problem of creating a safe electric environment for the care and comfort of the patients.
- The purpose of safety testing medical electronic equipment is to ensure that a device is safe from electrical hazards to patients, maintenance personnel's and users
- Electric shock is caused by electricity flowing through the body after touching a damaged electrical device and results muscle spasms, burns, cardiac and respiratory arrest and Ventricular Fibrillation

Electric safety in hospital is a shared responsibility between several parties, in addition to the physician, including:

- The nurses
- All engineers (electrical, biomedical, facility, etc)
- Manufacturers

Electrical Safety – Critical points to be checked

- The electrical installation, no matter how safe, is only part of the safety requirements.
- Plugs and cords must be checked and rejected if defective.

- Electrical compatibility of the entire electrical system must be tested regularly.
- Patients leads must be attached and connected properly.
- Radio-frequency devices (including mobile telephones) must be excluded

Basic safety should be performed on line powered before installation and after every repair are:

- Ground wire integrity ( Resistance )
- Ground wire leakage
- The basic electrical characteristic usually causes the most leakage currents in modern equipment is Capacitive Reactance Coupling in power cord.

### **Electric Shock Hazards**

It is a common experience that hazards due to electric shock are also associated with equipment other than that, used in hospitals.

The equipment's used in medical practice have to operate in special environments, which differ in certain respects from the others. Such special situations are as follows:

(i) A patient may not be usually able to react in the normal way. He is either ill, unconscious, anaesthetized or strapped on the operating table. He may not be able to withdraw himself from the electrified object, when feeling a tingling in his skin, before any danger of electrocution occurs.

(ii) The patient or the operator may not realize that a potential hazard exists. This is because potential differences are small and high frequency and ionizing radiations are not directly indicated.

(iii) A considerable natural protection and barrier to electric current is provided by human skin. In certain applications of electromedical equipment, the natural resistance of the skin may be by-passed. Such situations arise when the tests are carried out on the subject with a catheter in his heart or on large blood vessels.

(iv) Electromedical equipment, e.g., pacemakers may be used either temporarily or permanently to support or replace functions of some organs of the human body. An interruption in the power supply or failure of the equipment may give rise to hazards, which may cause permanent injuries or may even prove fatal for the patient.

(v) Medical instruments are quite often used in conjunction with several other instruments and equipment. These combinations are often ad-hoc. Several times there are combinations of high-power equipment and extremely sensitive low signal equipment. Each of these devices may be safe in itself, but can become dangerous when used in conjunction with others.

(vi) The environmental conditions in the hospitals, particularly in the operating theatres, cause an explosion or fire hazards due to the presence of anaesthetic agents, humidity and cleaning agents, etc. there are two situations which account for hazards from electric shock.

It is also obvious that an optimum level of safety can only be achieved when efforts are made to include safety measures in the equipment, in the installation as well as in the application.

There are two situations which account for hazards from electric shock:

- (i) gross shock and
- (ii) micro-current shock.

In the case of gross shock, the current flows through the body of the subject, e.g. as from arm to arm. The other case is that of micro-current shock in which the current passes directly through the heart wall. This is the case when cardiac catheters may be present in the heart chambers. Here, even very small amounts of currents can produce fatal results.

### **Gross Shock**

- Gross shock is experienced by the subject by an accidental contact with the electric wiring at any point on the surface of the body.
- The majority of electric accidents involve a current pathway- through the victim from one upper limb to the feet or to the opposite upper limb and they generally occur through intact skin surfaces.
- In all these cases, the body acts as a volume conductor at the mains frequency. For a physiological effect to take place, body must become part or an electric circuit. Current must enter the body at one point and leave at some other point. In this process, three phenomena can occur. These are:
  - (i) Electrical stimulation of the excitable tissues nerves and muscles
  - (ii) Resistive heating of tissue
  - (iii) Electro-chemical burns and tissue damage for direct current and very high voltages.
 The value of electric current, flowing in the body, which causes a given degree of stimulation, varies from individual to individual. Typical threshold values of current produce certain responses where the current flows into the body from external contacts (e.g. hand to hand) and these have been investigated. For a given voltage present on the surface of the body, the value of current passing through it would depend upon the contact impedance. Besides this, it depends on many other factors such usage, sex, condition of skin (dry or wet, smooth or rough, etc.), frequency of current. Duration of current and the applied voltage.

### Effects of Electric Current on the Human Body

- Threshold of Perception
- Let-go Current
- Physical Injury and Pain:
- Ventricular Fibrillation:
- Sustained Myocardial Contraction
- Burns and Physical Injury

### Micro-current Shock

- The threshold of sensation of electric currents differs widely between currents applied arm to arm and currents applied internally to the body.
- In the latter case, a far greater percentage of the current may flow via the arterial system directly through the heart, thereby requiring much less current to produce ventricular fibrillation. Such situations are commonly encountered in hospitals;

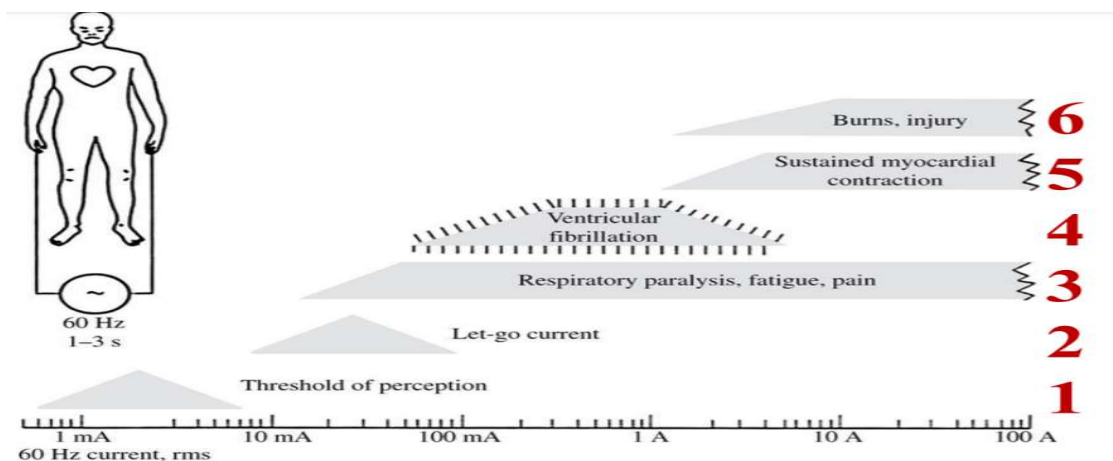

### Effect of Various Levels of Current on the Human Body



Current	Effect
1 milliampere	Tingling sensation, threshold of perception
5 milliamperes	Slight shock felt, not painful but disturbing
6 to 20 milliamperes	Painful shock, let-go range
50 milliamperes	Extreme pain, respiratory arrest, severe muscular contraction
100 milliamperes	Ventricular fibrillation
>5 amperes	possible burns, sustained myocardial contraction, respiratory paralysis and probable death

## Leakage Currents

- Currents of extremely small magnitude can be fatal to a patient when a direct, localized electrical path exists to the heart. Accidents of this nature can occur in unpredictable circumstances.
- Accidents can even occur with safe electro medical equipment being properly used if there are defects in the wiring of power outlets.
- **Leakage current** by definition is an inherent flow of non-functional current from the live electrical parts of an instrument to the accessible metal parts. Leakage currents usually flow through the third wire connection to the ground.
- The major source of potentially lethal currents in any instrument or equipment is the leakage current.
- They occur by the presence of a finite amount of insulation impedance, which consists of two parts: **Capacitance**  
**Resistance.**
- Leakage currents due to capacitance between any two conductors separated in space. Current flow shall take place if an alternating voltage is applied between them. The magnitude of the leakage current is determined by the value of the capacitance present therein. Leakage current of this type mostly originates due to capacitive coupling from the power transformer primary to other parts of the transformer or other parts of the instrument.
- The resistive component of leakage current arises because no substance is a perfect insulator and some small amount of current will always flow through it.
- However, this type of leakage current is usually very small as compared to the capacitive leakage currents and can be safely ignored.

## Types of Leakage Current

- **Enclosure Leakage Current**
- **Earth Leakage Current**
- **Patient Leakage Current**

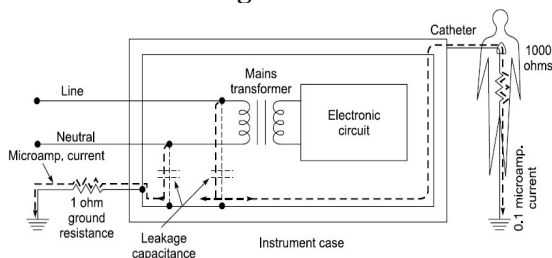

**Path of leakage current in a normal case of discontinuous ground**

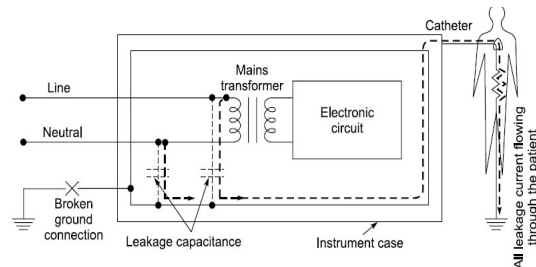

**Path of leakage current in case of broken ground connection**

### **Precautions to Minimize Electric Hazards**

- In the vicinity of the patient, use only apparatus or appliances with three-wire power cords.
- Provide isolated input circuits on monitoring equipment.
- Have periodic checks of ground wire continuity of all equipment.
- No other apparatus should be put where the patient monitoring equipment is connected.
- Staff should be trained to recognize potentially hazardous conditions.
- Connectors for probes and leads should be standardized so that currents intended for powering transducers are not given to the leads applied to pick up physiologic electric impulses.

### **POST MCQ:**

1. Monopolar needle electrodes are having coatings of which material over the stainless steel wires which are bare only at the tips?
  - a) Carbon
  - b) Calcium
  - c) Sodium
  - d) TeflonAnswer: d
2. Which electrode can be used to pick up signals from individual fibers of muscle tissues?
  - a) Bipolar needle electrode
  - b) Concentric core needle electrode
  - c) Multi-element needle electrode
  - d) Monopolar needle electrodeAnswer: c
3. \_\_\_\_\_ Instrument is used to hold patients head and guide the placement of electrodes.
  - a) Monotaxic
  - b) Stereotonic
  - c) Stereotaxic
  - d) Monotonic

Answer: c

4. The ground electrode is usually positioned over which body structures?

- a) Bony
- b) Hairy
- c) Fleshy
- d) Sweaty

Answer: a

5. When intramuscular EMG is required to look into the electrical activities of deeper or overlaid muscles, \_\_\_\_\_ electrodes are used.

- a) Plate shape electrodes
- b) Surface electrodes
- c) Thin thread electrodes
- d) Fine wire electrodes

Answer: d

#### UNIT -IV

#### IMAGING MODALITIES AND ANALYSIS

##### **AIM:**

To understand modern methods of imaging techniques.

##### **PRE MCQ**

1. Leucocytes are in the shape of \_\_\_\_\_

- a) Sphere
- b) Cube
- c) Hollow
- d) Cuboid

Answer: a

2. What should be the frequency response of the amplifiers that are used for the amplification purpose of the input signal in medical devices?

- a) High frequency response
- b) Low frequency response
- c) Frequency response has no role to play in it
- d) Average frequency response

Answer: b

3. To achieve the \_\_\_\_\_ required for medical applications, the amplifier must have large values of coupling capacitance.
  - a) Random frequency response
  - b) High frequency response
  - c) Average frequency response
  - d) Low frequency response
 Answer: d
4. High pass filter amplifies frequency \_\_\_\_\_.
  - a) Above certain value
  - b) Below certain value
  - c) Above and below certain value
  - d) At certain value
 Answer: a
5. Unit of Mean Platelet Volume is expressed in?
  - a) Millilitres
  - b) Femolitres
  - c) Picolitres
  - d) Decilitres
 Answer: c
6. Modern instrument use \_\_\_\_\_ for intravascular oximetry?
  - a) Photodiode
  - b) Red and infrared LED's
  - c) Optical fibre
  - d) Phototransistor
 Answer: c

## **THEORY:**

### **BASIS OF DIAGNOSTIC RADIOLOGY**

A Radiological examination is one of the most important diagnostic aids available in the medical practice. It is based on the fact that various anatomical structures of the body have different densities for the X-rays.

When X-rays from a point source penetrate a section of the body, the internal body structures absorb varying amounts of the radiation. The radiation that leaves the body has a spatial intensity variation, i.e. an image of the internal structure of the body.

The commonly used arrangement for diagnostic radiology The X-ray intensity distribution is visualized by a suitable device like a photographic film. A shadow image is generated that corresponds to the X-ray density of the organs in the body section.

The examination technique varies according to the clinical problem.

The main properties of X-rays, which make them suitable for the purposes of medical diagnosis, are:

- Capability to penetrate matter coupled with differential absorption observed in various materials
- Ability to produce luminescence and its effect on photographic emulsions.

The X-ray picture is called a **Radiograph**, which is a shadow picture produced by X-rays emanating from a point source.

The X-ray picture is usually obtained on photographic film placed in the image plane.

The skeletal structures are easy to visualize and even the untrained eye can sometimes observe fractures and other bone abnormalities.

Chest radiographs are mainly taken for examination of the lungs and the heart.

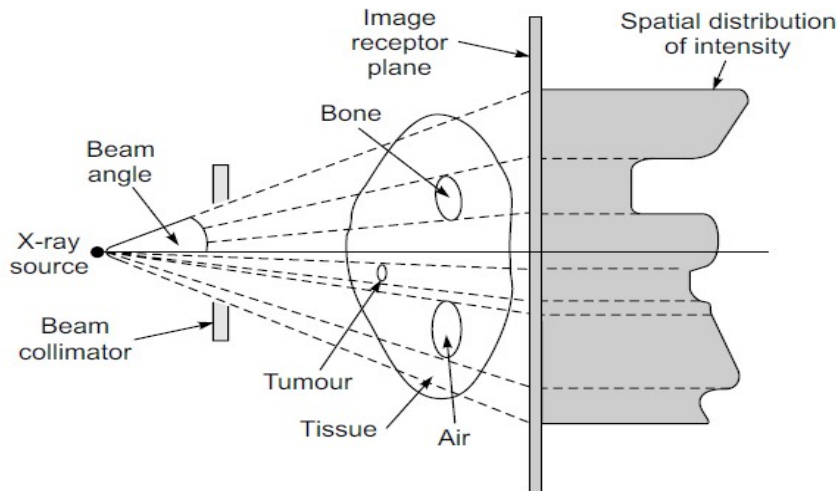

► Fig. 19.1 Basic set up for a diagnostic radiology image formation process

### Properties of X-ray

Because of short wavelength and extremely high energy, X-rays are able to penetrate through materials which readily absorb and reflect visible light. This forms the basis for the use of X-rays for radiography and even for their potential danger. X-rays are absorbed when passing through matter. The extent of absorption depends upon the density of the matter. X-rays produce secondary radiation in all matter through which they pass. This secondary radiation is composed of scattered radiation, characteristic radiation and electrons. In diagnostic radiology, it is scattered radiation which is of practical importance.

X-rays produce ionization in gases and influence the electric properties of liquids and solids. The ionizing property is made use of in the construction of radiation-measuring instruments. X-rays also produce fluorescence in certain materials to help them emit light. Fluoroscopic screens and intensifying screens have been constructed on the basis of this property. X-rays affect photographic film in the same way as ordinary visible light.

### X-ray imaging:

#### Properties of X-rays

- The X-rays in the medical diagnostic region have wavelength of the order of  $10^{-10}$  m. They propagate with a speed of  $3 \times 10^{10}$  cm/s and are unaffected by electric and magnetic fields.
- They have short wavelength and extremely high energy.
- X-rays are able to penetrate through materials which readily absorb and reflect visible light.
- X-rays are absorbed when passing through matter. The extent of absorption depends upon the density of the matter.
- X-rays produce secondary radiation in all matter through which they pass. This secondary radiation is composed of scattered radiation, characteristic radiation and electrons.
- X-rays produce ionization in gases and influence the electric properties of liquids and solids. The ionizing property is made use of in the construction of radiation-measuring instruments.
- X-rays also produce fluorescence in certain materials to help them emit light. Fluoroscopic screens and intensifying screens have been constructed on the basis of this property. X-rays affect photographic film in the same way as ordinary visible light.

### Production of X-rays

- X-rays are produced whenever electrons collide at very high speed with matter and are thus suddenly stopped. The energy possessed by the electrons appears from the site of the collision as a parcel of energy in the form of highly penetrating electromagnetic waves (X-rays) of many different wavelengths, which together form a continuous spectrum.
- X-rays are produced specially constructed glass tube, which basically comprises,
  - (i) a source for the production electrons,
  - (ii) a energy source to accelerate the electrons,
  - (iii) a free electron path,
  - (iv) a mean t focusing the electron beam and
  - (v) a device to stop the electrons.

Stationary mode tubes and rotating anode tubes are the two main types of X-ray tubes:

### Stationary Anode Tube

- the basic components of a stationary anode X-ray tube. The normal tube is a vacuum diode in which electrons are generated by thermionic emission from the filament of the tube.
- The electron stream is electrostatically focused on a target on the anode by means of a suitably shaped cathode cup.
- The kinetic energy of the electrons impinging on the target is converted into X-rays. Most electrons emitted by the hot element become current carriers across the tube.

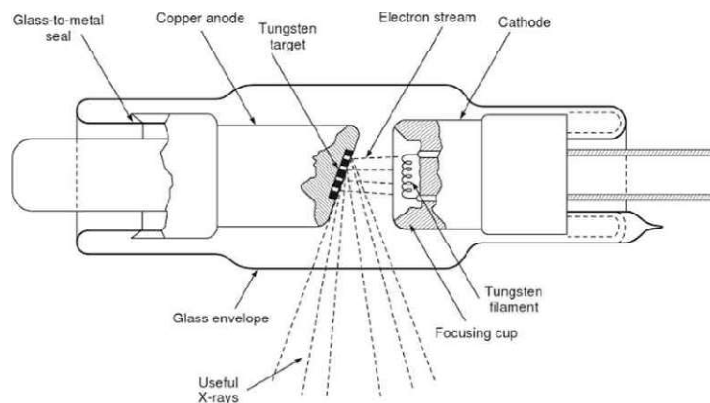

> Fig. 19.2 Construction of stationary anode X-ray tube

- Some X-ray tubes function as a triode with a bias voltage applied between the filament and the cathode cup.
- The cathode block, which contains the filament, is usually made from nickel or from a form of stainless steel. The filament is a closely wound helix of tungsten wire, about 0.2 mm thick, the helix diameter being about 1.0-1.5 mm.
- The target is normally comprised of a small tablet of tungsten about 15mm wide, 20mm long and 3mm thick soldered into a block of copper. Tungsten is chosen since it combines a high atomic number (74)—making it comparatively efficient in the production of X-rays. It has a high melting point (3400°C) enabling it to withstand the heavy thermal loads.
- Copper being an excellent thermal conductor, performs the vital function of carrying the heat rapidly away from the tungsten target. The heat flows through the anode to the outside of the tube, where it is normally removed by convection. Generally, an oil environment is provided for convection current cooling.
- In addition, the electrodes have open high voltages on them and must be shielded. The tube will emit X-rays in all directions and protection needs to be provided except where the useful beam emerges from the tube.

- In order to contain the cooling oil and meet the above-mentioned requirements, a metal container is provided for completely surrounding the tube. Such a container is known as a 'shield'.

### Rotating Anode Tube

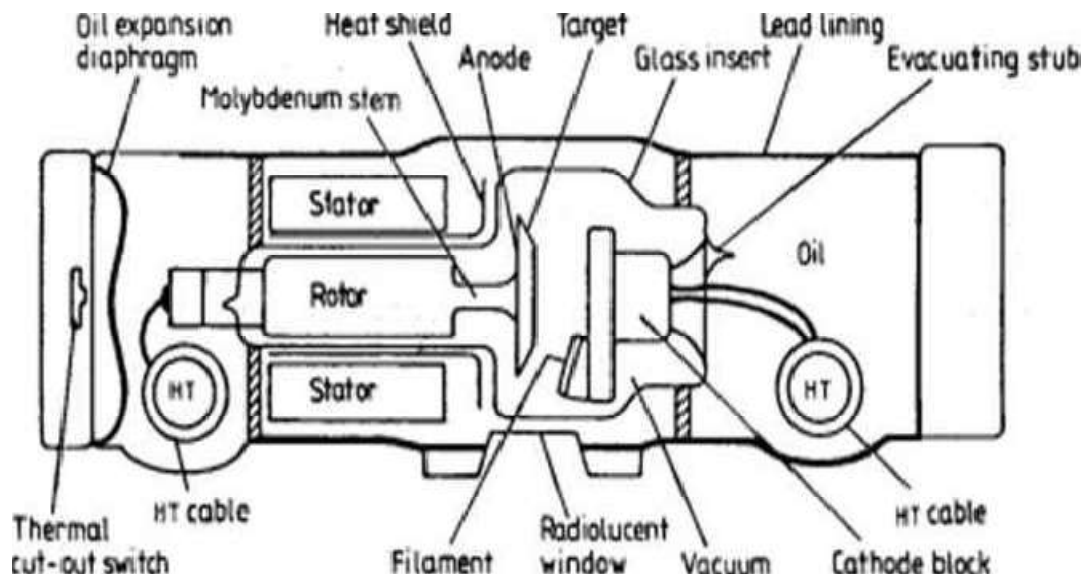

The filament is constructed from a spiral of tungsten wire (melting point  $3410^{\circ}\text{C}$ ), which is set in a nickel block. This block supports the filament and is shaped to create an electric field that focuses the electrons into a slit beam.

- The anode has a bevelled edge, which is at a steep angle to the direction of the electron beam. The exit window accepts x-rays that are approximately at right angles to the electron beam so that the x-ray source as viewed from the receptor appears to be approximately square even though the electron beam impinging on the target is slit-shaped.
- The choice of the anode angle will depend upon the application, with the angle being varied according to the requirements of field and focal spot sizes and tube output. For general-purpose units, an angle of about  $17^{\circ}$  is appropriate.
- Most of the energy in the electron beam is deposited in the target in the form of heat. The use of a slit source of electrons helps by spreading out the target area and this idea can be extended by using a rotating anode, so that the electron beam impinges on the bevelled edge of a rotating disc and the target area is spread out over the periphery of the disc.
- A rotation speed of about 3000 RPM and an anode diameter of 10 cm are used in general-purpose units.

### X-RAY MACHINE



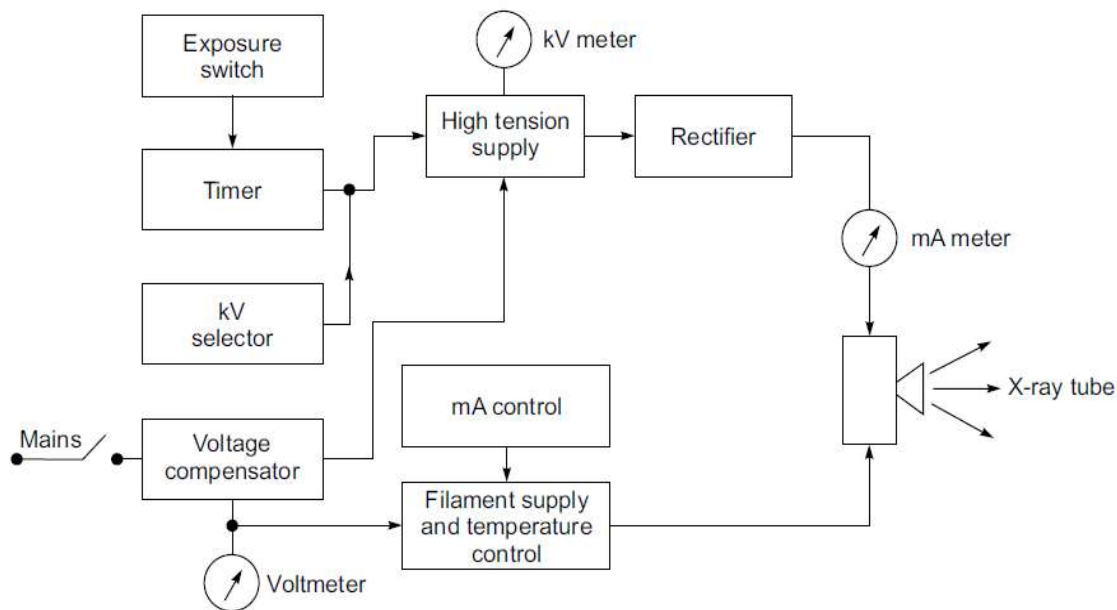

► Fig. 19.4 Block diagram of an X-ray machine

### Parts

1. X-Ray tube
2. High Tension Supply
3. Collimator
4. Patient Table.
5. Grid.
6. Radiographic film

### 1. X ray Tube

It is an important component of x-ray machine which is inaccessible as it is contained in a protective housing. It is a vacuum tube.

There are two primary parts.

- 1) Cathode
- 2) Anode.

### 2. Operating Console

It is an apparatus in X-Ray machine that allows to control the x-ray tube current and voltage.

The Console Controls are: -

1. Voltage compensator.
2. kV Meter.
3. mA Meter.
4. Exposure time.

### 1. Voltage Compensator

Because of variations in power distribution to the hospital and in power consumption by the various sections of the hospital, the voltage to the x-ray unit may vary by 5%, which will result in large variations in x-ray output.

### High Tension Supply with Rectifier

Power supply system consists of Autotransformer

- The power supplied to x-ray machine is delivered to a special transformer called an Autotransformer. It works on the principle of electromagnetic induction but is very different from conventional transformer.
- It has only one winding and one core. The single winding has number of connections, or electric taps. The purpose to use the Autotransformer is to overcome induction losses. Its value ranges from
- Used for producing high voltage which is applied to the tube's anode and cathode and comprises a high voltage step-up transformer followed by a rectifier.

### Self-Rectification Circuit for High Voltage Generation

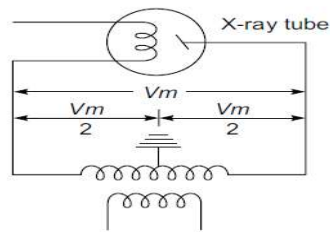

► Fig. 19.5 Self-rectified circuit for high voltage generation

The high voltage is produced using a step-up transformer whose primary is connected to auto-transformer. The secondary of the H.T. transformer can be directly connected to the anode of the x-ray tube which will conduct only during the half cycles when the cathode is negative with respect to anode or target.

- The current through the tube follows the H.T. pathway and is measured by a mA meter.
- A kV selector switch enables to change voltage between exposures. The voltage is measured with the help of a kV meter.
- The exposure switch controls the timer and thus the duration of the application of kV.
- To compensate for mains voltage variations, a voltage compensator is used in the circuit.
- The filament is heated with 6 to 12 V of ac supply at a current of 3 to 5 amperes. The filament temperature determines the tube current or mA, and, therefore, the filament temperature control has an attached mA selector. The filament current is controlled by using, in the primary side of the filament transformer, a variable choke or a rheostat. The rheostat provides a stepwise control of mA and is most commonly used in modern machines.
- These machines have maximum tube currents of about 20 mA and a voltage of about 100 kV. When self-rectification is used, it is necessary to use a parallel combination of a diode and resistance, in series with the primary of the H.T. transformer for suppressing higher inverse voltage likely to appear during the non-conducting half-cycle of the x-ray tube. This helps to reduce the cost and complexity of the x-ray machines.
- A preferred method of providing high voltage dc to the anode of the x-ray tube is by using a bridge rectifier using four valve tubes or solid-state rectifiers. This results in a much more efficient system than with half wave of self-rectification methods.
- The kV meter is connected across primary of the H.T. transformer. It actually measures volts whereas it is calibrated in kV by using an appropriate multiplication factor of turns-ratio of the transformer.
- In order to obtain the load voltage which varies with the tube current, a suitable kV meter compensation is provided in the circuit. The kV meter compensator is ganged to the mA selector mechanically. Therefore, the mA is selected first and the kV setting is made afterwards during operation of the machine
- Moving coil meters are used for making current I (mA) measurements, for shorter exposures, a mAs meter is used which measures the product I of mA and time in seconds.
- The exposure time is generally controlled by using some form of timing arrangement coupled with a contactor which supplies the H.T. to the anode of the x-ray tube only during that time.
- **Collimator:** The Collimator is attached to the x-ray tube below the glass window where the useful beam is emitted. Lead shutters are used to restrict the beam. Its purpose is to minimize field of view, to avoid unnecessary exposure by using lead plates.
- **Grid:** By virtue of function and material, collimator and grid are same but they have different location. It is made up of lead. It is located just after patient. It is used to destroy scattered radiation from the body.
- **Radiographic Film:** Two types of x-ray photon are responsible for density, contrast and image on a radiograph. Those that pass through the patient without interacting and those that are scattered in

the patient through Compton interaction. Together these x-rays that exit from the patient and intersect the film are called Remnant x-rays

## Fluoroscopy

The fluoroscopy procedure is an imaging technique that gathers real-time moving images using a fluoroscope of internal structures of patients. A fluoroscope consists of a fluorescent screen and an x-ray beam passing through your body. It mimics an x-ray movie, where continuous images display on a monitor.

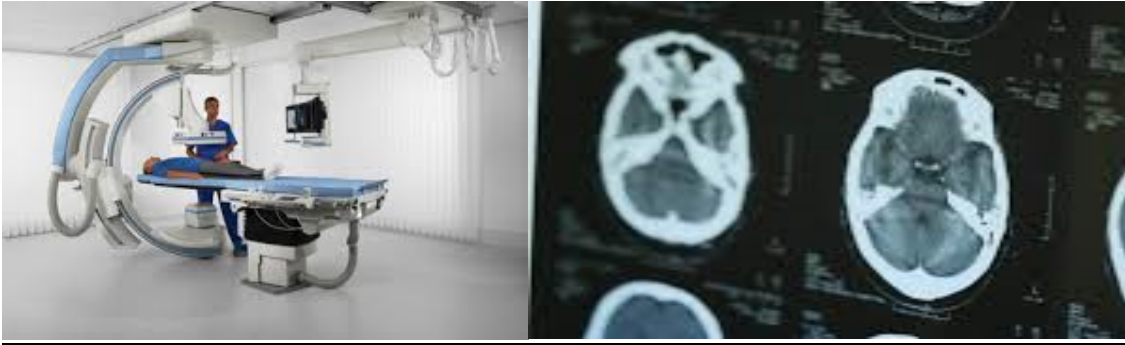

Fluoroscopy is extremely helpful to surgeons while they're performing surgical procedures. It enables doctors to see moving structures of the body and helps with diagnosing diseases. Fluoroscopy offers enormous benefits over invasive surgical procedures since it requires a tiny incision, significantly reducing your risk of infection and recovery time.

### **Fluoroscopic Equipment**

- High Voltage Generator
- X-Ray Tube (XRT)
- X-Ray Image Intensifier (XRII)
- Video Camera

XRII converts: low intensity X-ray photon fluence to high fluence of Visible Photons

Video Camera captures the XRII output image, and converts it to an analogue electrical signal that conforms to a recognized video format (e.g. NTSC/PAL/SECAM)

Modern Video Cameras - Charge-Coupled Device (CCD)

### **Fluoroscopy uses:**

- **Orthopaedic surgery:** Surgery concerned with musculoskeletal system conditions.
- **Catheter insertion:** Inserting a tube into the body.
- **Blood flow studies:** Visualizing the flow of blood to the organs.
- **Enemas:** Inserting a rubber tip into the rectum.
- **Angiography:** x-rays of lymph or blood vessels, including heart, leg and cerebral vessels.
- **Urological surgery:** Surgery of the urinary tract and sex organs.
- **Pacemaker implantation:** Implanting a small electronic device in the chest.

### **Risk**

There are some minor risks associated with fluoroscopy. Because it uses x-ray technology, you have some radiation exposure. The amount you absorb varies depending on the procedure length and your

size. Some individuals could experience radiation-induced injury to their skin that results in “burns” of their skin tissue.

### **Fluoroscopy Techniques**

- **Barium X-rays:** Fluoroscopy is used in barium x-rays to allow the doctor to see the movement as the intestines move the barium through them.
- **Electrophysiologic procedures:** With an electrophysiologic procedure, the doctor uses fluoroscopy to treat patients with irregular heartbeats.
- **Cardiac catheterization:** In this procedure, the doctor uses fluoroscopy to help them see the blood flow through the coronary arteries, checking for arterial blockages.
- **Arthrography:** This is an x-ray to view one or more joints. Today, catheter arthrography is one of the major uses of chest fluoroscopy.
- **Hysterosalpingogram:** This procedure is an x-ray of the fallopian tubes and uterus.
- **Placement of IV catheters:** Catheters are hollow, thin tubes the doctor puts into your arteries or veins. When inserting the IV catheter, the doctor will use fluoroscopy to guide the catheter inside your body into a specific location.
- **Percutaneous kyphoplasty/vertebroplasty:** A doctor uses this procedure to treat spinal vertebrae fractures.
- **Needle or transbronchial biopsies:** A doctor uses this procedure to obtain a biopsy of tissue from a lung.

### **COMPUTED TOMOGRAPHY**

#### **Limitations of X-rays**

1. The super-imposition of the three-dimensional information onto a single plane makes diagnosis confusing and often difficult.
2. The photographic film usually used for making radiographs has a limited dynamic range and, therefore, only objects that have large variations in X-ray absorption relative to their surroundings will cause sufficient contrast differences on the film to be distinguished by the eye. Thus, whilst details of bony structures can be clearly seen, it is difficult to discern the shape and composition of soft tissue organs accurately.
3. In such situations, growths and abnormalities within tissue only show a very small contrast difference on the film and consequently, it is extremely difficult to detect them, even after using various injected contrast media.
4. The problem becomes even more serious while carrying out studies of the brain due to its overall shielding of the soft tissue by the dense bone of the skull.

#### **Basic Principle of CT**

- In computed tomography (CT), the picture is made by viewing the patient via X-ray imaging from numerous angles, by mathematically reconstructing the detailed structures and displaying the reconstructed image on a video monitor.
- Computed tomography differs from conventional X-ray techniques in that the pictures displayed are not photographs but are reconstructed from a large number of absorption profiles taken at regular angular intervals around a slice, with each profile being made up from a parallel set of absorption values through the object.
- In computed tomography, X-rays from a finely collimated source are made to pass through a slice of the object or patient from a variety of directions. For directions along which the path.

- length through-tissue is longer, fewer X-rays are transmitted as compared to directions where there is less tissue attenuating the X-ray beam. In addition to the length of the tissue traversed, structures in the patient such as bone may attenuate X-rays more than a similar volume of less dense soft tissue.
- In principle, computed tomography involves the determination of attenuation characteristics for each small volume of tissue in the patient slice, which constitute the transmitted radiation intensity recorded from various irradiation directions. It is these calculated tissue attenuation characteristics that actually compose the CT image.

For a monochromatic X-Ray beam, the tissue attenuation characteristics can be described by,

$$I_t = I_o e^{-\mu x}$$

Where,

$I_o$  = Incident radiation intensity

$I_t$  = Transmitted intensity

$X$  = Thickness of tissue

$\mu$  = Characteristic attenuation coefficient of tissue

If a slice of heterogeneous tissue is irradiated given below, and we divide the slice into volume elements or voxels with each voxel having its own attenuation coefficient, it is obvious that the sum of the voxel attenuation coefficients for each X-ray beam direction can be determined from the experimentally measured beam intensities for a given voxel width. However, each individual voxel attenuation coefficient remains unknown.

Computed tomography uses the knowledge of the attenuation coefficient sums derived from X-ray intensity measurements made at all the various irradiation directions to calculate the attenuation coefficients of each individual voxel to form the CT image

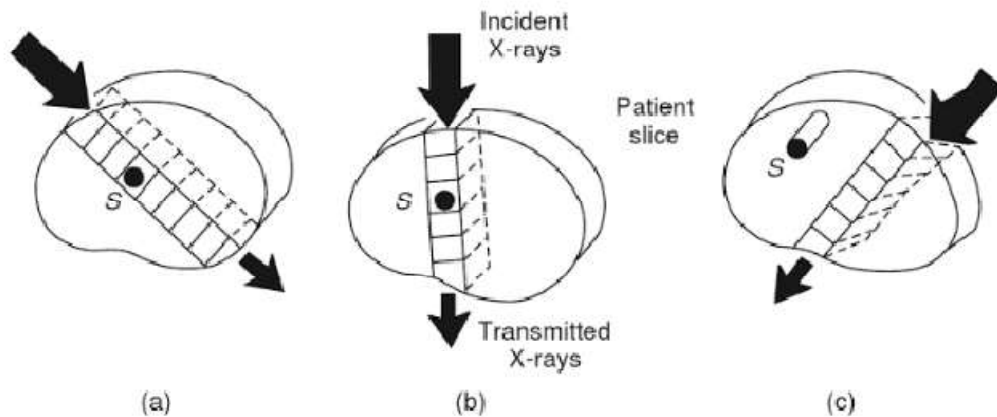

X-rays incident on patient from different directions. They are attenuated by different amounts, as indicated by the different transmitted X-ray intensities

### Block Diagram of the CT System

A Block diagram of the system. The X-ray source and detectors are mounted opposite each other in a rigid gantry with the patient lying in between, and by moving one or both of these around and across the relevant sections, which is how the measurements are made.

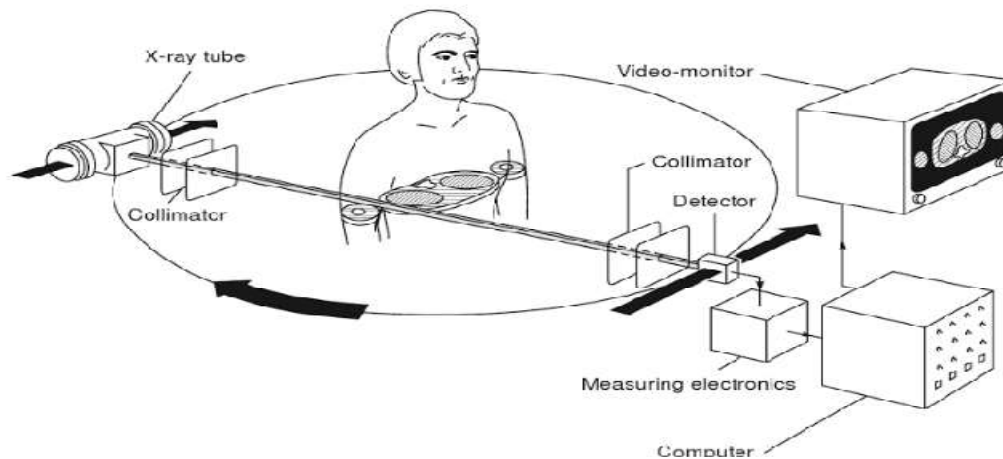

- The X-ray tube and the detector are rigidly coupled to each other. The system executes translational and rotational movement and trans radiates the patient from various angular projections. With the aid of collimators, pencil thin beam of X-ray is produced.
- A detector converts the X-radiation into an electrical signal. Measuring electronics then amplify the electrical signals and convert them into digital values. A computer then processes these values and computes them into a matrix-line density distribution pattern which is reproduced on a video monitor as a pattern of grey shade.
- In one system which employs 18 traverses in the 20s scanning cycle, 324,000 (18 x 30 x 600) X-ray transmission readings are taken and stored by the computer. These are obtained by integrating the outputs of the 30 detectors with approximately 600 position pulses.
- The position pulses are derived from a glass graticule that lies between a light emitting diode and photo-diode assembly that moves with the detectors. The detectors are usually sodium-iodide crystals, which are thallium-doped to prevent an after-glow. The detectors absorb the X-ray photons and emit the energy as visible light. This is converted to electrons by a photomultiplier tube and then amplified. Analog outputs from these tubes go through signal conditioning circuitry that amplifies, clips and shapes the signals.
- A relatively simple analog-to-digital converter then prepares the signals for the computer. Simultaneously, a separate reference detector continuously measures the intensity of the primary X-ray beam. The set of readings thus produced enables the computer to compensate for fluctuations of X-ray intensity. Also, the reference readings taken at the end of each traverse are used to continually calibrate the detection system and the necessary correction is carried out.
- After the initial pre-processing, the final image is put onto the system disc. This allows for direct viewing on the operator's console. The picture is reconstructed in either a 320 x 320 matrix of 0.73 mm squares giving higher spatial resolution or in a 160x 160 matrix of 1.5 mm, squares which results in higher precision, lower noise image and better discrimination between tissues of similar density.
- Each picture element that makes up the image matrix has a CT number, say between -1000 and + 1000, and therefore, takes up one computer word. A complete picture occupies approximately 100 K words, and up to eight such pictures can be stored on the system disc. There is a precise linear relationship between the CT numbers and the actual X-ray absorption values, and the scale is defined by air at -1000 and by water at 0.

### Image Reconstruction

The formation of a CT image is a distinct three phase process.

1. The scanning phase produces data, but not an image.
2. The reconstruction phase processes the acquired data and forms a digital image.
3. Digital-to analog conversion phase: The visible and displayed analog image (shades of gray) is produced by the digital-to analog conversion phase.

## 1. The scanning phase

- During the scanning phase a fan-shaped x-ray beam is scanned around the body. The amount of x-radiation that penetrates the body along each individual ray (pathway) through the body is measured by the detectors that intercept the x-ray beam after it passes through the body.
- The projection of the fan-shaped x-ray beam from one specific x-ray tube focal spot position produces one view. Many views projected from around the patient's body are required in order to acquire the necessary data to reconstruct an image. Each view produces one "profile" or line of data as shown here.
- The complete scan produces a complete data set that contains sufficient information for the reconstruction of an image. In principle, one scan produces data for one slice image.

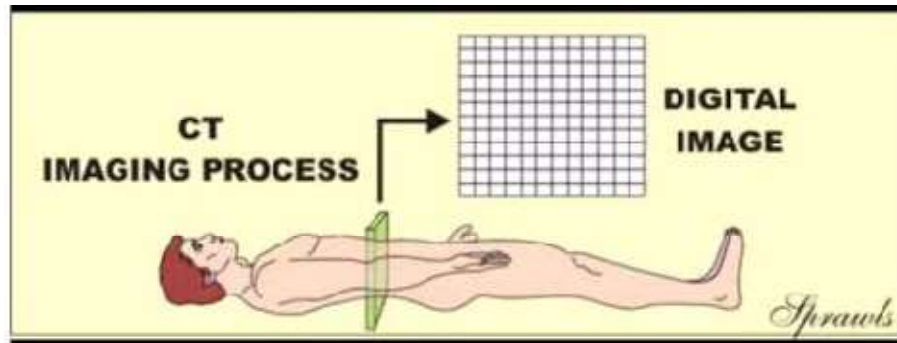

## 2. Image Reconstruction Phase

Image reconstruction is the phase in which the scan data set is processed to produce an image. The image is digital and consists of a matrix of pixels. Filtered back projection is the reconstruction method used in CT. "Filtered" refers to the use of the digital image processing algorithms that are used to improve image quality or change certain image quality characteristics, such as detail and noise. "Back projection" is the actual process used to produce or "reconstruct" the image.

### Back projection Principle

We start with one scan view through a body section (like a head) that contains two objects. As we know, the data produced is not a complete image, but a profile of the x-ray attenuation by the objects. Let's now take this profile and attempt to draw an image by "back projecting" the profile onto our image surface.

We have now rotated the x-ray beam around the body by 90° and obtained another view. If we now back project this profile onto our image area we see the beginnings of an image showing the two objects. Two views does not give us a high-quality image. Several hundred views are used to produce clinical CT images. A part of the reconstruction process is the calculation of CT number values for each image pixel.

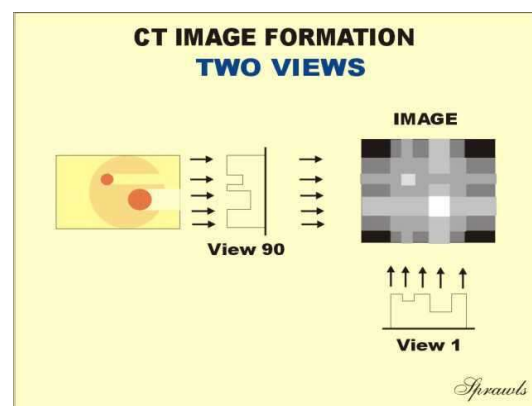
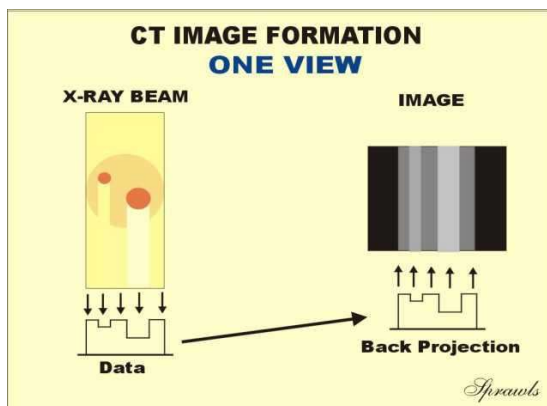



### Image Reconstruction Computer, used in CT scanners.

This method enables pictures to be reconstructed within a few seconds. Figure shows a block diagram image reconstruction computer, used in CT scanners.

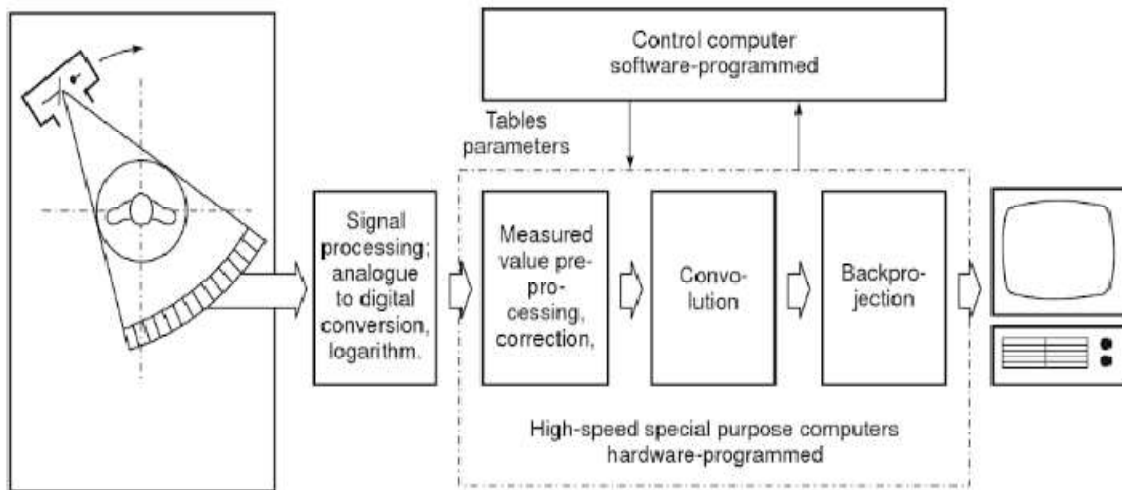

► Fig. 20.13 Block diagram of the image computer. The synchronous reconstruction of the image permits the representation of the tomogram on the video monitor immediately upon completion of the scan (Courtesy: Siemens, Germany)

### Ultrafast Electron Beam CT Scanner

In this electron beam sweeps back and forth through a magnetic field. The impact of electron beam on a semi-circular tungsten array underneath the patient generates X-rays and the X ray detectors are mounted on a semi-circular array above the patient.

Light weight, Takes only 50ms with electron beam tomography.

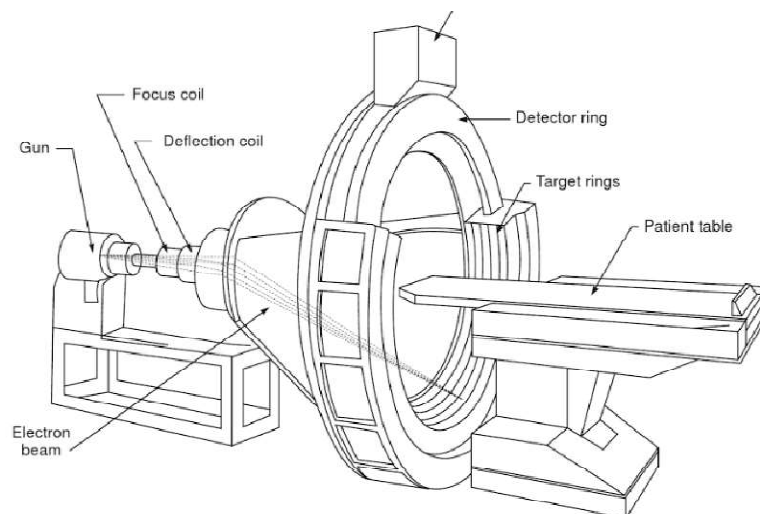

- The detector array consists of two continuous ranges of 216° with 432 channels each. Luminascent crystals coupled to silicon photo-diodes are used.
- The scanning electron beam emitted by an electron gun is accelerated by 130-140 kV, electromagnetically focused and deflected over a target in a typical time of 50-100 ms.

- It was originally designed for cardiac examinations. The unit was equipped for this purpose with four anode rings and two detector rings which enabled eight contiguous slices, an area of approximately 8x8 mm. to be scanned without movement of the patient.

### Spiral /Helical Scanning.

This is a scanning technique in which the X-ray tube rotates continuously around the patient while the patient is continuously translated through the fan beam. The focal spot therefore, traces a helix around the patient. The projection data thus obtained allow for the reconstruction of multiple contiguous images. This operation is often referred to as helix, spiral, volume, or three-dimensional CT scanning. This technique has been developed for acquiring images with faster scan times and to obtain fast multiple scans for three-dimensional imaging to obtain and evaluate the Volume at different locations.

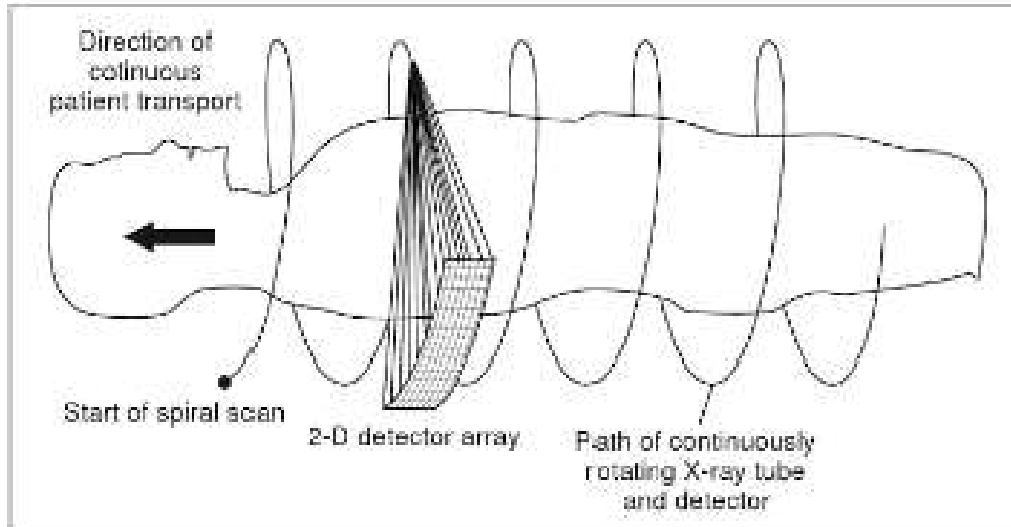

The spiral scanning technique, which causes the focal spot to follow a spiral path around the patient. Multiple images are acquired while the patient is moved through the gantry in a smooth continuous motion rather than stopping for each image. The projection data for multiple images covering a volume of the patient can be acquired in a single breath hold at rates of approximately one slice per second.

### Processing System

A typical data acquisition system, it consists of precision pre-amplifiers, current to voltage converter, analog integrators, multiplexers and analog-to-digital converters. Data transfer rates of the order of 10 Mbytes/s are required in some scanners. This can be accomplished with a direct connection for systems having a fixed detector array. The third generation slip ring systems make use of optical transmitters on the rotating gantry to send data to fixed optical receivers.

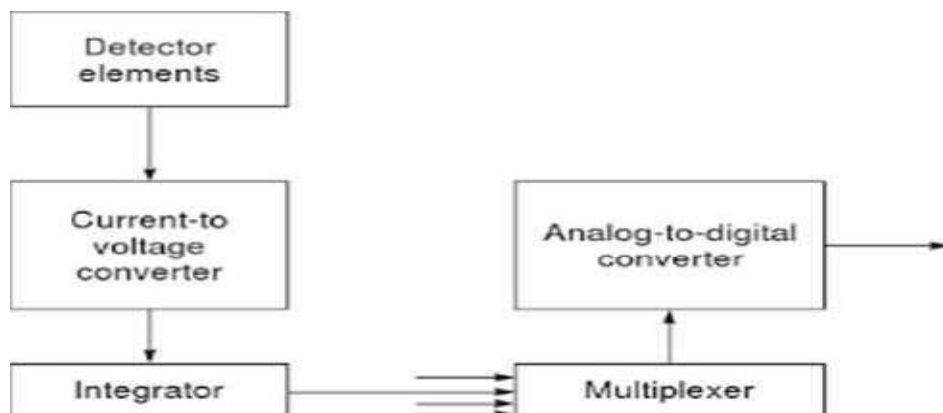

### Magnetic Resonance Imaging (MRI)

Magnetic resonance imaging (MRI) is a spectroscopic imaging technique used in medical settings to produce images of the inside of the human body. MRI is based on the principles of nuclear magnetic resonance (NMR), which is a spectroscopic technique used to obtain microscopic chemical and physical data about molecules.



### **Comparison of NMR system and XRAY and CT**

1. Similar to the X-ray computerized tomography (CT), MRI uses magnetic fields and radio frequency signals to obtain anatomical information about the human body as cross-sectional images in any desired direction and can easily discriminate between healthy and diseased tissue.
2. MRI images are essentially a map of the distribution density of hydrogen nuclei and parameters reflecting their motion, in cellular water and lipids.
3. The total avoidance of ionizing radiation, its lack of known hazards and the penetration of bone and air without attenuation make it a particularly attractive non-invasive imaging technique.
4. CT provides details about the bone and tissue structure of an organ whereas NMR highlights the liquid-like areas on those organs and can also be used to detect flowing liquids, like blood.
5. A conventional X-ray scanner can produce an image only at right angles to the axis of the body, whereas the NMR scanner can produce any desired cross-section, which offers a distinct advantage to and is a big boon for the radiologist.

### **Basic Principle**

MRI systems provide highly detailed images of tissue in the body. The systems detect and process the signals generated when hydrogen atoms, which are abundant in tissue, are placed in a strong magnetic field and excited by a resonant magnetic excitation pulse. All materials contains nucleus that have a combination of protons and neutrons. It possesses a spin and the amount of spin give rise to a magnetic moment. The magnetic moment has a magnitude and direction. In tissues Magnetic moments of nuclei making up the tissue are randomly aligned and net magnetization=0. Random alignment of magnetic moments of the nuclei making up the tissue, resulting in a zero net magnetization. When a material is placed in a magnetic field  $B_0$ , some of the randomly oriented nuclei experience an external magnetic torque which tends to align the individual parallel or anti-parallel magnetic moments to the direction of an applied magnetic field. This gives a magnetic moment that accounts for the nuclear magnetic resonance signal on which the imaging is based. This moment is in the direction of applied magnetic field  $B_0$ . With the magnetic moments being randomly oriented with respect to one another, the components in the X-Y plane cancel one another out while the Z components along the direction of the applied magnetic field add up to produce this magnetic moment  $M_0$  shown in Figure given below.

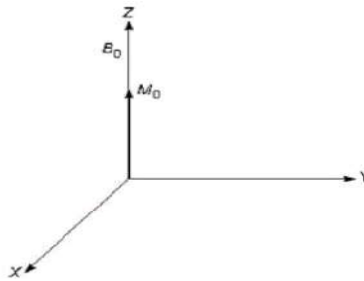

The application of external magnetic field causes the nuclear magnetic moments to align themselves, producing a net moment in the direction of the field  $B_0$

### NMR Resultant Signal Pick up by the Instrument

- When a nucleus with a magnetic moment is placed in an externally applied magnetic field, the energy of the nucleus is split into lower (moment parallel with the field) and higher (anti-parallel) energy levels. The energy difference is such that a proton with specific frequency (energy) is necessary to excite a nucleus from the lower to the higher state.
- The excitation energy  $E$  obtained by the application of external RF signal, and is given by the Planck's equation  $E = h\omega$  Where  $h$  is Planck's constant. This energy is usually supplied by an RF magnetic field.  $\omega$  = Frequency of applied RF.
- The excited proton tends to return or relax to its low-energy state with spontaneous decay and re-emissions of energy at a later time  $T$  in the form of radio wave photons. This decay is exponential in nature and produces a “free induction decay” (FID)

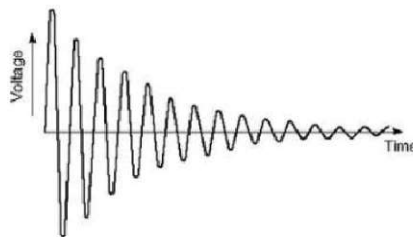

Free induction decay (FID) signal obtained in NMR experiments

- To summarize, if in a static field, RF waves of the right frequency are passed through the sample of interest (or tissue), some of the parallel protons will absorb energy and be stimulated or excited to a higher energy in the anti-parallel direction. Sometime later, the RF frequency absorbed will be emitted as electromagnetic energy of the same frequency as the RF source. The amount of energy required to flip protons from the parallel to the anti-parallel orientation is directly related to the
- Magnetic field strength; stronger fields require more energy or higher frequency radiation. This is picked up by the instrument and then processed.

### BASIC NMR COMPONENTS

The basic components of an NMR imaging system are shown in Fig. These are:

1. **Magnet:** Provides a strong uniform, steady, magnet field  $B_0$ .
2. **RF transmitter**, which delivers radio-frequency magnetic field to the sample.
3. **Gradient system**, which produces time-varying magnetic fields of controlled spatial non-uniformity;
4. **Detection System**, which yields the output signal; and
5. **Imager system**, including the computer, which reconstructs and displays the images.

#### 1. Imager System

- The Imaging sequencing in the system is provided by a computer. Functions such as gates and envelopes for the NMR pulses, blanking for the pre-amplifier and RF power amplifier and voltage waveforms for the gradient magnetic fields are all under software control.
- The computer also performs the various data processing tasks including the Fourier transformation, image reconstruction, data filtering, image display and storage. Therefore, the computer must have sufficient memory and speed to handle large image arrays and data processing, in addition to interfacing facilities.

## 2. The Magnet:

- In magnetic resonance tomography, the base field must be extremely uniform in space and constant in time as its purpose is to align the nuclear magnets parallel to each other in the volume to be examined.
- Also, the signal-to-noise ratio increases approximately linearly with the magnetic field strength of the basic field, therefore, it must be as large as possible.
- Four factors characterize the performance of the magnets used in MR systems; viz., field strength, temporal stability, homogeneity and bore size.
- The gross non-homogeneities result in image distortion while the bore diameter limits the size of the dimension of the specimen that can be imaged. Such a magnetic field can be produced by means of four different ways, viz., permanent magnets, electromagnets, resistive magnets and super-conducting magnets.

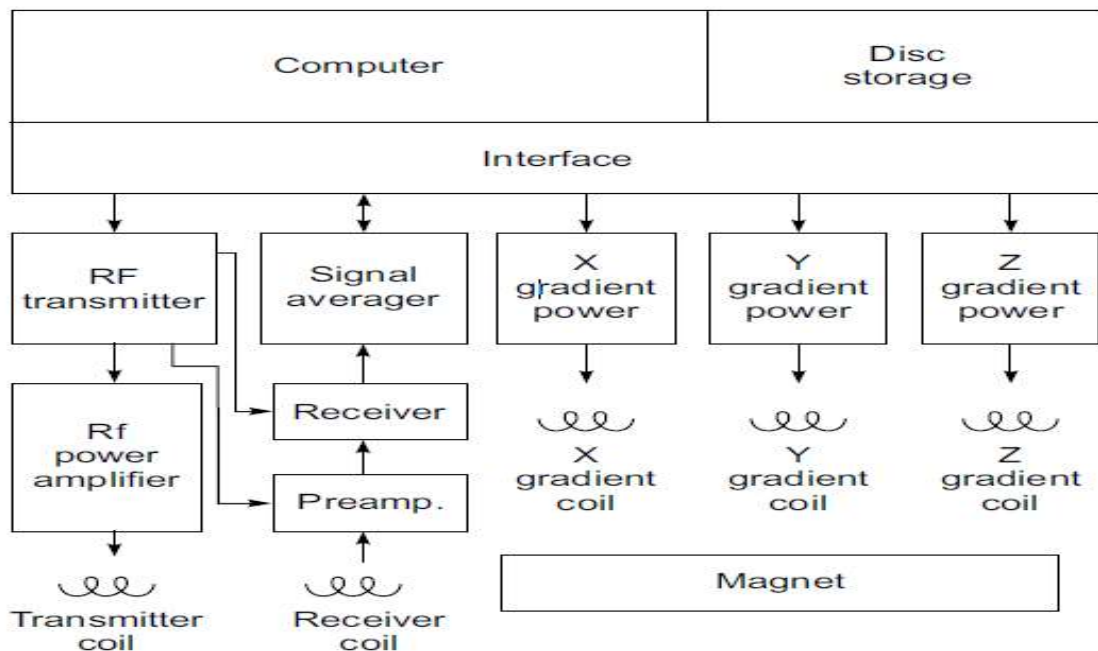

- **Permanent Magnet:** In case of the permanent magnet, the patient is placed in the gap between a pair of permanently magnetized pole faces. Permanent magnet materials normally used in MRI scanners include high carbon iron alloys such as alnico or neodymium iron.. Although permanent magnets have the advantages of producing a relatively small fringing field and do not require power supplies, they tend to be very heavy (up to 100 tons) and produce relatively low fields of the order of 0.3 T or less.
- **Electromagnets:** Make use of soft magnetic materials such as pole faces which become magnetized only when electric current is passed through the coils wound around them. Electromagnets obviously require external electrical power supply.
- **Resistive magnets:** make use of large current-carrying coils of aluminium strips or copper tubes. In these magnets, the electrical power requirement increases proportionately to the square of the

field strength which becomes prohibitively high as the field strength increases. Moreover, the total power in the coils is converted into heat which must be dissipated by liquid cooling.

- **Superconductive magnets.** Most of the modern NMR machines utilize superconductive magnets. These magnets utilize the property of certain materials, which lose their electrical resistance fully below a specific temperature. The commonly used superconducting material is Nb Ti (Niobium Titanium) alloy for which the transition temperature lies at 9 K (-264°C). In order to prevent superconductivity from being destroyed by an external magnetic field or the current passing through the conductors, these conductors must be cooled down to temperatures significantly below this point, at least to half of the transition temperature. Therefore, superconductive magnet coils are cooled with liquid helium which boils at a temperature of 4.2 K (-269°C).

### RF Transmitter System

- The system consists of an RF transmitter, RF power amplifier and RF transmitting coils. 1. RF Transmitter System
- In order to activate the nuclei so that they emit a useful signal, energy must be transmitted into the sample. This is what the transmitter does.
- The RF transmitter consists of an RF crystal oscillator at the Larmor frequency. The RF voltage is gated with the pulse envelopes from the computer interface to generate RF pulses that excite the resonance.

### RF Power Amplifier

- These pulses are amplified to levels varying from 100W to several kW and are fed to the transmitter coil.

### RF Transmitting Coils

- The coil generates RF field perpendicular to the direction of main magnetic field.
- Coils are tuned to the NMR frequency and are usually isolated from the remaining system using RF shielding cage.

### Detection System

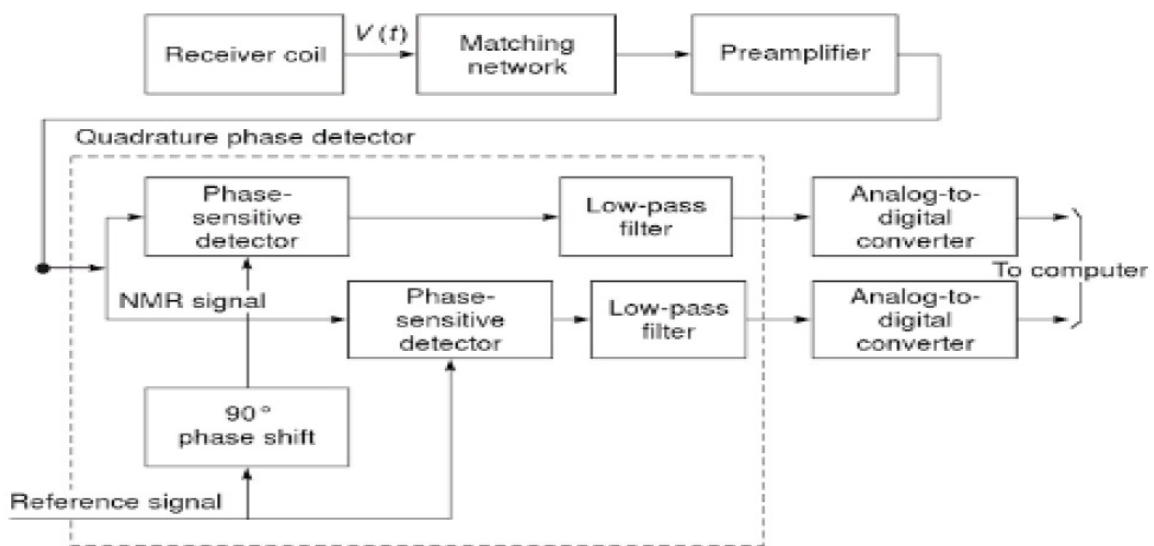

*Block diagram of the NMR detection system*

The function of detection system is to detect the nuclear magnetization and generate an output signal for processing by the computer.

The receiver coil usually surrounds the sample and acts as an antenna to pick up the fluctuating nuclear magnetization of the sample and converts it to a fluctuating output voltage  $V(t)$ .

$$V(t) = -\frac{d}{dt} \cdot M(t, x) \cdot B_c(x) d_v$$

NMR signal is given by

- Where  $M(t, x)$  is the total magnetization in a volume and  $B_c(x)$  the sensitivity of the receiver coil at different points in space.  $B_c(x)$  describes the ratio of the magnetic field produced by the receiver coil to the current in the coil.
- The receiver coil design and placement is such that  $B_c(x)$  has the largest possible transverse component. The longitudinal component of  $B_c(x)$  contributes little to the output voltage and can be ignored.
- The RF signals constitute the variable measured in magnetic resonance tomography. These are extremely weak signals having amplitude in the nV (nano-Volt) range thus requiring specially designed RF antennas. The sensitivity of an MR scanner therefore depends on the quality of its RF receiving antenna. For a given sample magnetization, static magnetic field strengths and sample volume, the signal-to-noise-ratio (SNR) of the RF signal at the receiver depends in the following manner upon the RF-receiving antenna.

$$SNR \sim K(Q/V_c)$$

Where  $K$  is a numerical constant, specific to the coil geometry

$Q$  is the coil magnetization factor, and

$V_c$  is the coil volume.

- This implies that the SNR of an MR scan can be improved by maximizing magnetization to coil volume.
- Some of the commonly available coils are:
- Body Coils: Constructed on cylindrical coils forms with diameter ranging from 50 to 60 cm entirely surround the patient's body.
- Head Coils: Designed only for head imaging, with typical diameter of 28 cm.

#### Surface coils:

- Orbit/ear coil: flat, planar ring-shaped coil with 10 cm diameter; Neck coil: flexible, rectangular shaped surface coil (10 cm x 20 cm) capable of adaptation to the individual patient anatomy; and Spine coil: cylindrical or ring-shaped coil with 15 cm diameter.

#### Organ-enclosing coils:

Helmholtz-type coil: a pair of flat ring coils each having 15 cm diameter with distance between the two coils variable from 12 to 22 cm.

#### Matching Network

Following the receiver coil is a *matching network* which couples it to the pre-amplifier in order to maximize energy transfer into the amplifier. This network introduces a phase shift to the phase of the signal.

#### Pre-amplifier:

The pre-amplifier is a low-noise amplifier which amplifies the signal and feeds it to a quadrature phase detector.

#### Quadrature phase detector

The detector accepts the RF NMR signal which consists of a distribution of frequencies centred around or near the transmitted frequency  $\omega$  and shifts the signal down in frequency by  $\omega$ . The detector circuit accepts the inputs, the NMR signal  $V(t)$  and a reference signal, and multiplies them, so that the output is the product of the two inputs. The frequency of the reference signal is the same as that of the



irradiating RF pulse. The output of the phase-sensitive detector consists of the sum of two components, one a narrow range of frequencies centred at  $2\omega_0$ , and the other, a narrow range centred at zero. The low pass filter following the phase-sensitive detector removes all components except those centred at zero from the signal.

### ADC

It is necessary to convert the complex (two-channel) signal to two strings of digital numbers by analog-to-digital converters. The A-D converter output is passed, in serial data form to the computer for processing.

### Gradient System for Spatial Coding:

Spatial distribution information can be obtained by using the fact that the resonance frequency depends on the magnetic field strength. By varying the field in a known manner through the specimen volume, it is possible to select the region of the specimen from which the information is derived on the basis of the frequency of the signal. The strength of the signal at each frequency can be interpreted as the density of the hydrogen nuclei in the plane within the object where the magnetic field corresponds to that frequency.

The imaging methods differ mainly in the nature of the gradient time dependence (static, continuously time-dependent or pulsed), and in the type of NMR pulse sequence employed. Spatial information and therefore images obtained by super-imposing a linear magnetic field gradient on the uniform magnetic field applied to the object to be imaged. When this is done, the resonance frequencies of the processing nuclei will depend primarily on the positions along the direction of the magnetic gradient. This produces a one-dimensional projection of the structure of the three-dimensional object. By taking a series of these projections at different gradient orientations, a two or even three-dimensional image can be produced.

In NMR systems, for spatially resolving the signals emitted by the object, the initially homogeneous magnetic field  $B_0$  is overlaid in all three spatial dimensions, X, Y, Z with small linear magnetic fields-gradient fields G.

These gradient fields are produced with the aid of current carrying coils and can be switched on or off as desired, both during the application of the RF energy and also in any phase of the measuring procedure.

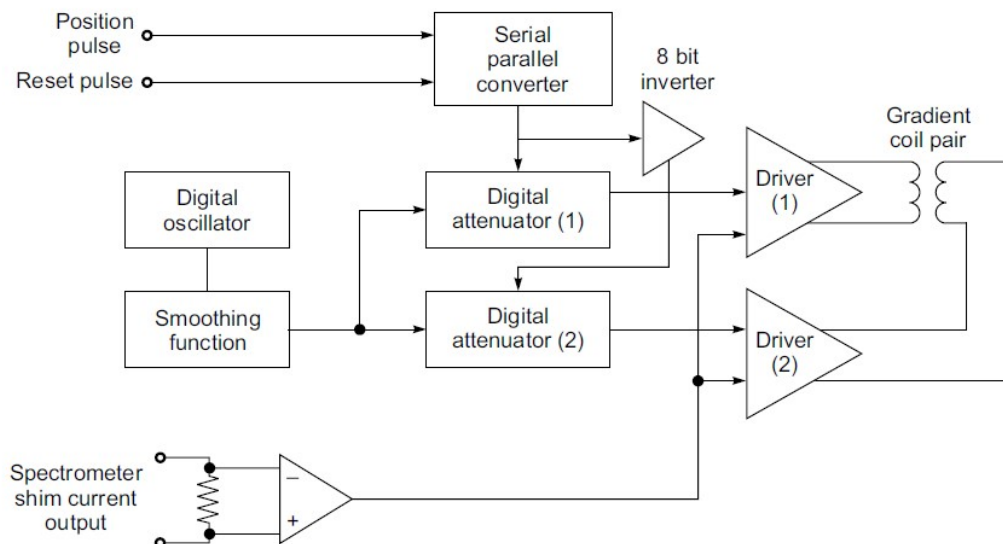

### Serial Parallel Computer

The first sub-system includes the interface between the computer and the gradient control system. Its primary function is to allow the independent positioning of the three planes (X, Y and Z).

### 2. The digital oscillator

Consists of a 555-timer followed by shift registers A digital oscillator facilitates varying its output frequency over an extremely wide range through the use of a single control.

- The 8-bit input from the interface circuit is used directly to one attenuator while the same 8-bits are inverted to control the second attenuator. The output of the attenuators is then voltage-amplified by two op amps prior to the driven circuits.
- Current control used to adjust the static field gradients be available for setting the DC levels upon which the alternating gradients are superimposed.
- An op amp serves the differential voltage drop across a dummy load and produces an output which is then DC coupled to the drivers.
- The high current drivers use a conventional design with a single op amp providing the input to a driver and a complimentary pair of power transistors to provide a sufficient current to the gradient coil.
- In typical scanners, gradient coils have an electric resistance of about 1 Ohm and an inductance of 1 mH. The gradient fields are required to be switched from 0 to 10 mT/ m in about 0.5 ms. the current switches from 0 to about 100 A in this interval. The power dissipation during the switching interval is about 20 kW. This places very strong demands on the power supply and it is often necessary to use water cooling to prevent overheating of the gradient coils.
- With well-designed coils, errors resulting from non-linear gradients will perhaps not be evident in a medical image since the image will remain clear and will not contain rigidly shaped objects or those with sharp edges for close comparison. But these gradient coils are usually designed to optimize linearity in the central region. Away from the centre, gradient linearity becomes progressively worse. Without restoration, the image will not give accurate information on the outer regions. Therefore, non-linear field gradients result in a geometrical distortion of the image reconstructed from projections.

### **Imager System**

The imager system includes the computer for image processing, display system and control console. The timing and control of RF and gradient pulse sequences for relaxation time measurements and imaging, in addition to FT image reconstruction and display necessitate the use of a computer. The computer is the source of both the voltage waveforms of all gradient pulses and the envelopes of the RF pulses. A general-purpose mini-computer of the type used for a CAT scanner is adequate for these purposes.

### **BIOLOGICAL EFFECTS OF NMR IMAGING**

The three aspects of NMR imaging which could cause potential health hazard are:

(i) Heating due to the rf power.

A temperature increase produced in the head of NMR imaging would be about 0.3°C. This does not seem likely to pose a problem.

(ii) Static magnetic field:

No significant effects of the static field with the level used in NMR are known, but the possible side effects of electromagnetic fields are decrease in cognitive skills, mitotic delay in slime moulds, delayed wound healing and elevated serum triglycerides.

(iii) Electric current induction due to rapid change in magnetic field:

It is believed that oscillating magnetic field gradients may induce electric currents strong enough to cause ventricular fibrillation. However, no damage due to NMR

### **ADVANTAGES OF NMR IMAGING SYSTEM**

1. The NMR provides substantial contrast between soft tissues that are nearly identical.
2. NMR uses no ionizing radiation and has minimal hazards for operators of the machines and for patients.
3. Unlike CT, NMR imaging requires no moving parts, gantries or sophisticated crystal detectors.
4. The system scans by superimposing electrically controlled magnetic fields consequently, scans in any pre-determined orientation are possible.

5. With the new techniques being developed, NMR permits imaging of entire three-dimensional volumes simultaneously instead of slice by slice, employed in other imaging systems.
6. In NMR both biochemical (spectroscopy) and spatial information (imaging) can be obtained without destroying the sample.

### POSITRON EMISSION TOMOGRAPHY (PET) SCANNER

- Positron emission tomography is an imaging modality for obtaining in vivo cross-sectional images of positron-emitting isotopes that demonstrate biological function, physiology or pathology. Unlike anatomical imaging techniques like computed tomography (CT), X-ray, and ultrasound, PET imaging provides “functional” information about the human body. In this technique, a chemical compound with the desired biological activity is labelled with a radioactive isotope that decays by emitting a positron, or positive electrons.
- The emitted positron almost immediately combines with an electron and the two are mutually annihilated with the emission of two gamma rays. The two gamma ray photons travel in almost opposite directions, penetrate the surrounding tissue and are recorded outside the subject by a circular array of detectors
- A mathematical algorithm applied by computer rapidly reconstructs the spatial distribution of the radioactivity within the subject for a selected plane and displays the resulting image on the monitor.
- Thus, PET provides a non-invasive regional assessment of many biochemical processes that are essential to the functioning of the organ being visualized.
- The positron ( $\beta^+$ ) is emitted from a proton-rich nucleus with a variable amount of kinetic energy, the maximum amount being the endpoint energy ( $E_{\beta^+}$ ), given for various isotopes

• Table.21.2 Positron Emitters Commonly used in PET

Isotope	$E_{\beta^+}$ , (MeV)	$T^{1/2}$ (min)
$^{15}\text{O}$	1.74	2.07
$^{11}\text{C}$	0.96	20.39
$^{13}\text{N}$	1.19	9.96
$^{18}\text{F}$	0.65	109.77
$^{38}\text{K}$	2.68	7.64
$^{68}\text{Ga}$	1.90	68.1
$^{82}\text{Rb}$	3.35	1.27
$^{63}\text{Zn}$	2.32	38.1

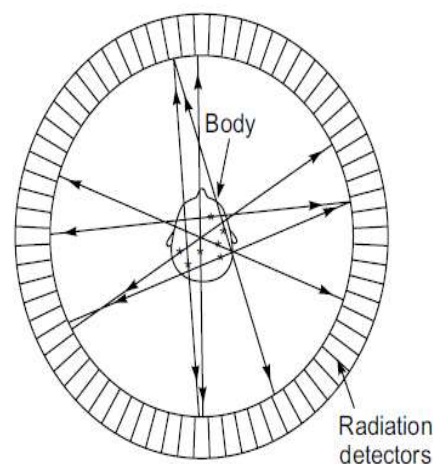

► Fig. 21.15 Principle of positron emission tomography (PET) scanner

- This energy is dissipated in the patient over a range of tissue of the order of a few millimetres. The  $\beta^+$  combines with a free electron ( $\beta^-$ ) and the masses are transmuted to two 511-keV gamma rays which are emitted at  $180^\circ \pm 0.25^\circ$  to one another to satisfy conservation of momentum. The variable finite range of the  $\beta^+$  as well as the angular variation of about  $180^\circ$  are fundamental limitations to the resolution achievable with PET.
- The compounds used and quantitated are labelled with proton-rich positron ( $\beta^+$ ) emitters that are usually cyclotron-produced. The principal isotopes are  $^{11}\text{C}$ ,  $^{13}\text{N}$ ,  $^{15}\text{O}$ , and  $^{18}\text{F}$ . If the compound of interest is labelled in a known position and it maintains this positron, a PET scan permits measurement of the positron concentration ( $\mu\text{Ci/mL}$ ) in a small-volume element within an organ or region of interest. This metabolic volume is typically  $1\text{ cm}^3$ .  
Two design types of positron-emission tomographs have been introduced

- One employing opposed large-area detectors which require rotation around the patient to provide the necessary degree of angular sampling another employing multiple individual crystal detectors surrounding the patient in a circular or hexagonal array.
- Conventional lead absorption:
- Collimators are not required because the coincident detection of two 511 keV photons indicates the line of origin along which the photons were emitted. However, in order to reduce the random coincidence count rate, some degree of collimation is normally employed.
  - Pulse processing needs to be much faster than with single-photon systems, to keep random coincidences to manageable proportions. With fast-response detectors and suitably fast electronics, it may be possible to use the difference in the time of arrival of the annihilation photons at opposed detectors to locate the site of positron decay and improve spatial resolution.
  - The gantry has a large opening and can image both the brain and torso of adult patient.
  - Axially, the two rings are separated by 36 mm. Besides containing the two BGO crystals and PMTs, the bucket also contains amplifiers/discriminators and other front-end processing electronics.
  - In order to increase linear sampling, the entire detector assembly can wobble in a small circular orbit. This wobbling procedure is used to optimize spatial resolution.

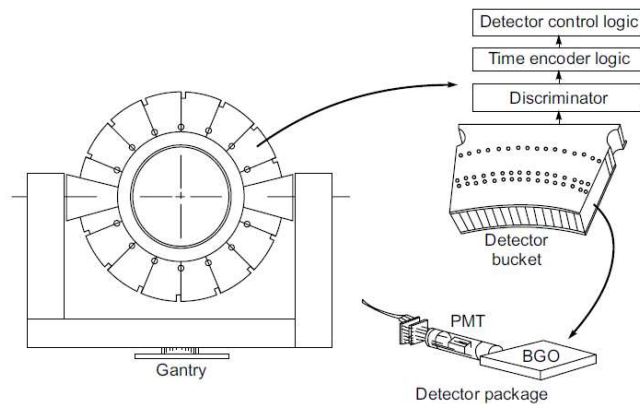

► Fig. 21.17 Gantry and detector modules used in PET scanner (after Hoffman et al., 1985)

The original PET scanners were constructed using a thallium-doped sodium iodide (NaI (TI)) detector. Its high efficiency at 511 keV, ease of fabrication, and low cost made it an obvious choice in a number of initial designs utilizing discrete crystals. Its principal disadvantage in PET work was the decreasing detection efficiency caused by the trend toward smaller crystals required for high resolution while maintaining a reasonably high total system efficiency.

A new generation of high resolution, high-efficiency PET scanners has become possible.

The use of CdZnTe (CZT) and CdTe room temperature semiconductors as detectors. CZT and CdTe can be made into large detectors for reading out resolution elements. One of the main differences between the two materials is the charge transport properties. The actual differences can favour either CZT or CdTe depending on the growth techniques used and the temperature of the devices. Most investigators have reported that the charge mobility of CdTe is somewhat better (typically on the order of 20%) at room temperature. The devices generally have much better energy resolution than scintillator based detectors and can be made to provide very good spatial resolution.

### Block diagram of a PET system.

- The PET detector is comprised of an array of thousands of scintillation crystals and hundreds of photomultiplier tubes (PMTs) arranged in a circular pattern around the patient. The current signal from each PMT output is converted to a voltage and amplified by a low-noise amplifier (LNA). The signal generated by the PMT is a pulse with a fast attack and slow decay.

- The signal strength from each PMT is determined by digitally integrating the area under this time-domain pulse. The system uses a variable-gain amplifier (VGA) after the LNA to compensate for variability in the sensitivity of the PMTs

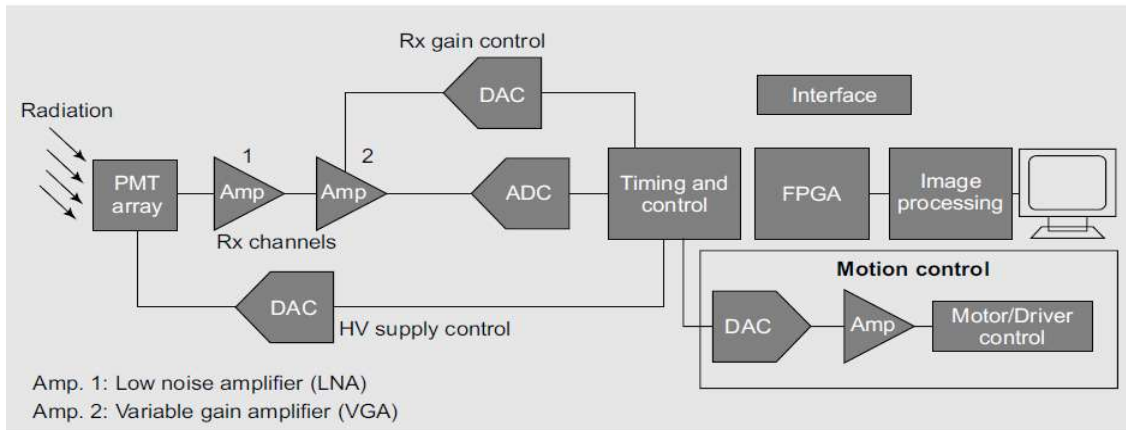

► Fig. 21.18 Block diagram of a PET scanner system (Adapted from MI's Texas Instruments)

- The combined LNA and VGA gain is approximately 40dB. The amplifiers used typically have noise of a few  $nV/\sqrt{\text{Hz}}$  or less, with bandwidths in the 100 kHz to 1GHz range. Current feedback amplifiers are sometimes used to provide high speed while minimizing power.
- High-density digital-to-analog converters (DACs) with 10-bit to 12-bit resolution are used to control the gain of the VGAs. The VGA's output is passed through a lowpass filter, offset compensated, and then converted to a digital signal by a 10-bit to 12-bit analog-to-digital converter (ADC) sampling at a 50 Msps to 100 Msps (mega samples/second) rate. The ADC samples are typically processed by a field programmable gate array (FPGA) discriminator which can process multiple ADC outputs.
- The signals from a number (typically four or more) of physically close PMTs are summed, and this combined signal drives the input of an ultra-high-speed comparator. A DAC generates the comparator's reference voltage to compensate for DC offsets. Extremely high accuracy is required to calculate time of flight, so a digital timestamp is generated using the comparator's output signal and an ultra-high-speed clock. In this way, timing information can be compared for multiple PMTs that are physically separated by a significant distance.
- The photon pair defines a line on which the collision took place. This is called the line of response (LOR)
- Newer, higher performance PET systems are now using the time-stamps of the two photon-strike events to determine the approximate location of the collision site on the LOR. This technique improves image quality.
- Signal processing is needed for detector signal processing of the receive channels and for a number of control functions. Digital Signal Processors (DSPs), microcontrollers and digital-to-analog converters are used for functions such as varying input amplifier gain, controlling the PMT high-voltage power supply, and motion control for the detector ring assembly and patient entry/exit. Filtered back-projection algorithms can be used in image reconstruction.



► Fig. 21.19 A typical PET system in use



## SINGLE-PHOTON-EMISSION-COMPUTED TOMOGRAPHY (SPECT)

- SPECT is a nuclear imaging scan that integrates computed tomography (CT) and a radioactive tracer. The tracer is what allows doctors to see how blood flows to tissues and organs. Most stationary and some mobile gamma cameras can perform SPECT
- SPECT cameras detect only radio-nuclides that produce a cascaded emission of single photons.
- SPECT radio-nuclides do not require an on-site cyclotron. However, the isotopes of Tc, TI, In, and Xe are not normally found in the body.
- SPECT has been used mainly in the detection of tumours and other lesions, as well as in the evaluation of myocardial function using TI-201. However, certain pharmaceuticals have been labelled with iodine and technetium and provide information on blood perfusion within the brain and the heart.
- The projection data are combined to produce transverse (also called axial or trans-axial) slices. Sagittal and coronal image slices can also be produced through mathematical manipulation of the data.
- SPECT systems with multiple camera heads are also available. In a dual-head system, two 180° opposed camera heads are used, and acquisition time is reduced by half with no loss in sensitivity.
- A triple-head SPECT system further improves sensitivity. Some suppliers also offer variable-angle dual-head systems for improved positioning during cardiac, brain and whole-body imaging. Imaging times can be decreased by using another SPECT configuration—a ring of detectors completely surrounding the patient.
- Although multiple camera heads reduce acquisition time, they do not significantly shorten procedure/exam time because of factors such as patient preparation and data processing
- The sensitivity of a SPECT system is mainly determined by the total area of the detector surface that is viewing the organ of interest.

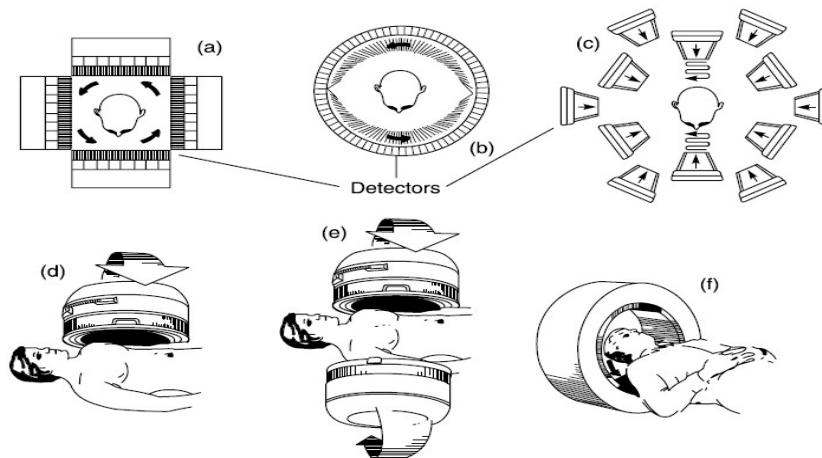

► Fig. 21.13 Examples of several discrete detector and camera-based approaches for SPECT

- Camera-based approaches for SPECT have the advantage of generating true three-dimensional images of the entire organ of interest. An obvious method to improve the sensitivity of these systems is to use more than a single camera
- A pallet, designed to minimize gamma ray attenuation, supports the patient between the two scintillation cameras. The camera separation is radially adjustable from 22 to 66 cm detector surface-to-surface. This adjustment range permits the collimators to be in close proximity to the patient for both body and brain scans. The data are collected with continuous gantry motion during a 360° rotation.
- Acquisition times may be varied from 2 to 26 minutes. Angular samples are stored into 2° frames.

- The two NaI (TI) crystals, each having a useful field-of-view of 40.6 cm, are 9.5 mm thick. Each detector crystal is optically coupled to an array of 37 photo-multiplier tubes. Detector electronics include the circuitry to compensate for positioning non-linearities and regional sensitivity variations.

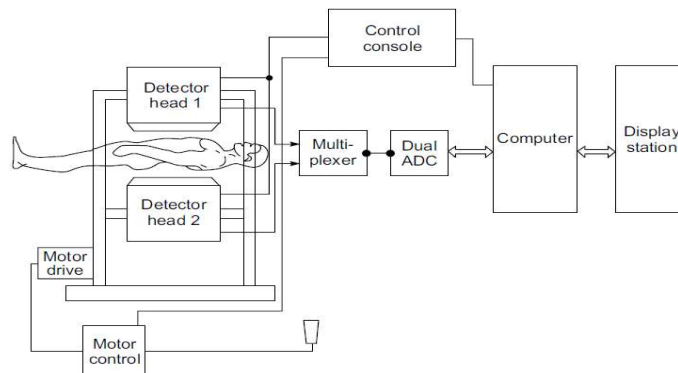

► Fig. 21.14 Simplified diagram of SPECT system consisting of dual large field-of-view scintillation cameras mounted on a rotatable gantry

- During acquisition, each x-y pair of gamma ray event coordinates is digitized into a 128 (Perpendicular to axis-of-rotation (x)) by 64 (parallel to axis-of-rotation (y)) storage array inbuffer memory, together with a detector identifying bit and energy window identifying bit.
- Besides the primary photo-peak window, a secondary energy window is simultaneously used to record events which have undergone Compton scattering within the patient.
- Multi-slice projection set conversion and angular framing are done in real-time by the computer. The resulting projections may then be stored on disc or magnetic tape for later image reconstruction. The fast and common evaluation method for reconstruction of images in SPECT is by means of filtered back projection. Parallel hole collimation is used for imaging organs such as the liver, lungs and the heart. For the brain.
- Image display is accomplished on a system interfaced to a computer. A 256 × 256 image format with 256 shades of gray with windowing and background subtraction is available.
- The image display station is directly interfaced to a film recorder. Either transparencies or rapid-process prints may be produced.
- An ECG gate is interfaced to the system. Thus, it is possible to acquire multi-gated end-diastolic and end-systolic SPECT images of the heart. Coronal and sagittal sectional images are generated from the set of contiguous transverse slices using a data re-organization algorithm.
- A SPECT scan is primarily used to view how blood flows through arteries and veins in the brain. Tests have shown that it might be more sensitive to brain injury than either MRI or CT scanning because it can detect reduced blood flow to injured sites.
- SPECT scanning is also useful for presurgical evaluation of medically uncontrolled seizures (Fig. 1). The test can be performed between seizures (interictal) or during a seizure (ictal) to determine blood flow to areas where the seizures originate.

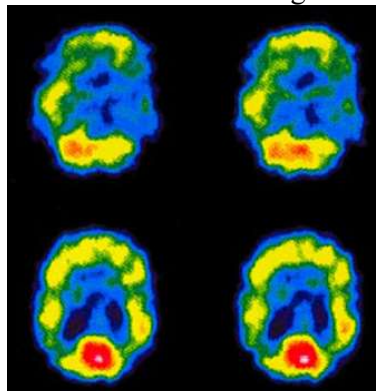



### **The temporal lobe on the left side of the brain shows less blood flow than the right**

- This type of scanning is also useful in diagnosing stress fractures in the spine (spondylolysis), blood deprived (ischemic) areas of brain following a stroke, and tumors.

## **Ultrasonography**

The term ultrasound refers to acoustical waves above the range of human hearing (frequencies higher than 20,000 Hz). Medical ultrasound systems operate at frequencies of up to 10 MHz or more.

An ultrasonic wave is acoustical. Ultrasonic imaging is used in medicine, engineering, geology, and other scientific areas. Radio signals are electromagnetic waves, while medical ultrasound signals are acoustical.

- Ultrasound is a non-invasive diagnostic tool used to complement other imaging modalities.
- The degree to which the ultrasound beam penetrates the patient and the image resolution obtained depend on the frequency of the transducer used.
- Artifacts can be beneficial or detrimental to image interpretation
- Ultrasonography is the use of high-frequency sound waves to generate an image. Because ultrasonography is relatively safe and non-invasive, it has become a useful diagnostic tool in veterinary medicine.<sup>1</sup> Veterinary technicians, especially those who wish to learn how to perform ultrasound examinations, should have a basic understanding of ultrasonography: how sound waves are produced and interact with tissue, what types of images can be obtained, how to get the best image, and how to identify common artifacts.
- Ultrasound examinations complement other imaging modalities, such as radiography, and allow more definitive diagnostic tests to be conducted. However, ultrasonography is limited by the fact that it is user dependent.
- This means that the quality of the images obtained and their accurate interpretation depend on the experience and knowledge of the sonographer

## **Ultrasound**

### **Physical Properties**

- Sound is a wave of energy that, unlike x-rays, must be transmitted through a medium. Sound waves can be described by their frequency, wavelength, and velocity. The frequency is the number of cycles or waves that are completed every second, and the wavelength is the distance needed to complete one wave cycle. The frequency of the sound waves used in ultrasonography is well above the limit of the human ear (20,000 kHz) — usually in the range of 2 to 12 MHz (2 to 12 million Hz).
- An inverse relationship exists between the frequency and the wavelength of a sound wave: the higher the frequency, the shorter the wavelength. This relationship affects the choice of frequency used in each patient undergoing ultrasonography. Higher-frequency ultrasound waves create higher-resolution images, but their shorter wavelength makes them unable to penetrate deeper tissues. Lower-frequency waves have better penetrating power, but because of their longer wavelengths, their resolution is lower. Weighing the need for higher resolution versus more penetrating power is always a consideration when selecting a transducer frequency.
- The velocity of an ultrasound wave is independent of the frequency. However, it changes depending on the medium through which the wave is traveling

### **Image Production**

- Two basic principles need to be understood regarding how ultrasound is generated and an image is formed. The first is the **piezoelectric effect**, which explains how ultrasound is generated from ceramic crystals in the transducer. An electric current pass through a cable to the transducer and is applied to the crystals, causing them to deform and vibrate. This vibration produces the ultrasound beam. The frequency of the ultrasound waves produced is predetermined by the crystals in the transducer.

- The second key principle is the **pulse-echo principle**, which explains how the image is generated. Ultrasound waves are produced in pulses, not continuously, because the same crystals are used to generate and receive sound waves, and they cannot do both at the same time. In the time between the pulses, the ultrasound beam enters the patient and is bounced or reflected back to the transducer. These reflected sound waves, or echoes, cause the crystals in the transducer to deform again and produce an electrical signal that is then converted into an image displayed on the monitor. The transducer generally emits ultrasound only 1% of the time; the rest of the time is spent receiving the returning echoes

### Interaction with Tissue

Ultrasound produced by the transducer interacts with different tissues in a variety of ways that may help or hinder image formation. Attenuation and refraction are the two major types of tissue interaction.

**Attenuation** is the gradual weakening of the ultrasound beam as it passes through tissue. Attenuation can be caused by reflection, scattering, or absorption of the sound waves and is compensated for by use of specific controls, discussed below.

**Reflection** takes place when ultrasound waves are bounced back to the transducer for image generation. The portion of the ultrasound beam that is reflected is determined by the difference in acoustic impedance between adjacent structures.<sup>5</sup> Acoustic impedance is the product of a tissue's density and the velocity of the sound waves passing through it; therefore, the denser the tissue, the greater the acoustic impedance. The large differences in density and sound velocity between air, bone, and soft tissue create a correspondingly large difference in acoustic impedance, causing almost all of the sound waves to be reflected at soft tissue-bone and soft tissue-air interfaces. On the other hand, because there is little difference in acoustic impedance between soft tissue structures, relatively few echoes are reflected to the transducer from these areas.

**Scattering** refers to the redirection of ultrasound waves as they interact with small, rough, or uneven structures. This tissue interaction occurs in the parenchyma of organs, where there is little difference in acoustic impedance, and is responsible for producing the texture of the organ seen on the monitor. Scattering increases with higher-frequency transducers, thus providing better detail or resolution.

**Absorption** occurs when the energy of the ultrasound beam is converted to heat. This occurs at the molecular level as the beam passes through the tissues.<sup>5</sup>

**Refraction** occurs when the ultrasound beam hits a structure at an oblique angle. The change in tissue density produces a change in velocity, and this change in velocity causes the beam to bend, or *refract*. This type of tissue interaction can also cause artifacts that need to be recognized by the sonographer.

### Display Modes

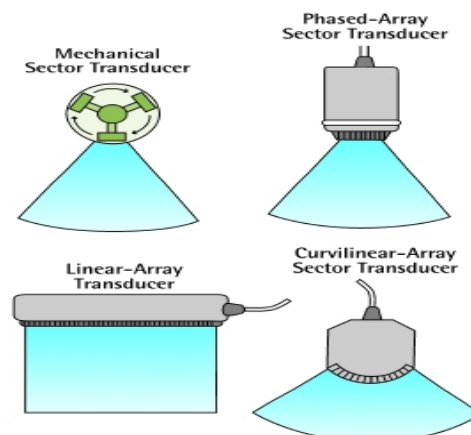

▲ Diagrams of different transducer types.

## A (Amplitude) Mode

In A mode, the returning echoes are displayed on the monitor as spikes originating from a single vertical or horizontal baseline.<sup>5</sup> The depth of the echo is determined by the position of the spike on the axis, with the top or left side of the monitor being the most superficial and the bottom or right side being farther away. The height of the spike correlates to the amplitude of the echo. This mode is not frequently used other than in ophthalmology.

## B (Brightness) Mode

In B mode, echoes are represented by dots on a line that form the basis of a two-dimensional image. The brightness of each dot indicates the amplitude of the returning echo. Its location relative to the transducer is displayed along the vertical axis of the monitor, with the top of the monitor representing the transducer. The returning echo's location along the axis is based on the amount of time it takes for the ultrasound wave to be transmitted from the transducer and reflected back. Echoes arising from structures in the near field (close to the transducer) take less time than those coming from the far field (farther away from the transducer) because they travel a shorter distance.

Real-time B mode ultrasonography allows a complete, two-dimensional, cross-sectional image to be generated by using multiple B-mode lines.<sup>5</sup> In real-time B mode, the transducer sweeps the ultrasound beam through the patient many times a second. With each pass of the ultrasound beam, multiple lines of dots are generated on the monitor, producing a complete image. These B-mode lines remain on the monitor until the next sweep of the ultrasound beam. Because several beam sweeps are performed per second, a moving, changing, "real-time" image is generated. This is the mode most commonly used in veterinary practice.

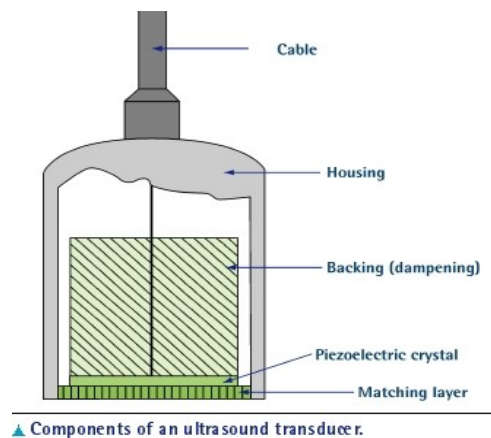

## M (Motion) Mode

M mode is used in echocardiography and allows the sonographer to measure the heart to assess cardiac function and chamber size. M mode uses a single B-mode line, with the amplitude of the echoes indicated by the brightness of the displayed dots. The difference is that the information obtained from that single line is constantly swept across the monitor so that the motion of the body part being investigated is displayed along the horizontal axis.

## Image Optimization

To obtain good-quality images, the sonographer must know what type and size of transducer to use and how to use the available ultrasound controls. There are many transducers or probes from which to choose, and selection of the appropriate one depends on the location of structures to be imaged and the size of the patient.

## Transducers

Transducers are first classified as *linear* or *sector*, according to the arrangement (array) of the crystals and the shape of the imaging field produced on the monitor. In a linear transducer, the crystals are oriented in a straight line, producing a rectangular image in which both the near and far fields are wide. Linear transducers provide superior resolution of near-field structures and therefore are commonly

used in equine reproduction and tendon examinations.<sup>5</sup> However, their large footprint can limit their use in cardiac and abdominal studies, where it may be difficult to fit the probe between the ribs.



▲ An ultrasound console showing the time gain compensation sliders and the depth and gain controls. Names and locations of ultrasound controls vary from unit to unit.



**Ultrasonography of Kidney**

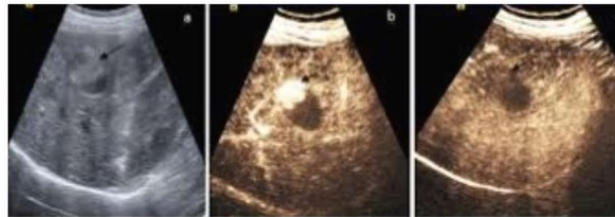

Gray Sclae i

## **Endoscopy**

- Endoscopy is a nonsurgical procedure used to examine a person's digestive tract.
- Using an endoscope, a flexible tube with a light and camera attached to it, your doctor can view pictures of your digestive tract on a colour TV monitor.
- Endoscopy is the insertion of a long, thin tube directly into the body to observe an internal organ or tissue in detail. It can also be used to carry out other tasks including imaging and minor surgery.
- Endoscopes are minimally invasive and can be inserted into the openings of the body such as the mouth or anus.
- Alternatively, they can be inserted into small incisions, for instance, in the knee or abdomen. Surgery completed through a small incision and assisted with special instruments, such as the endoscope, is called keyhole surgery.
- Because modern endoscopy has relatively few risks, delivers detailed images, and is quick to carry out.

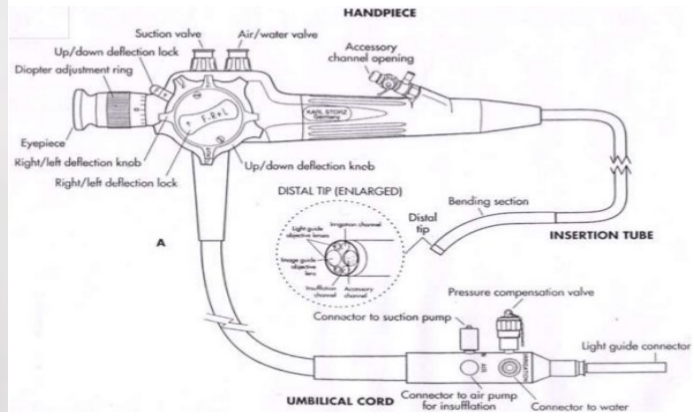

### Endoscopymachine Parts of Endoscopy

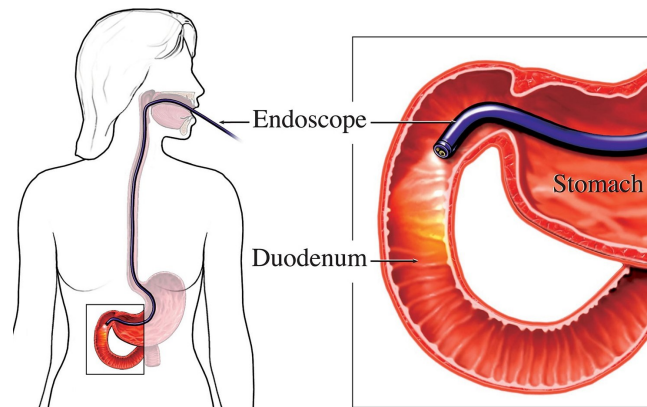

An endoscope consist of:

- A rigid or flexible tube.
- A light delivery system to illuminate the organ or object under inspection. The light source is normally outside the body and the light is typically directed via an optical fiber system.
- A lens system transmitting the image from the objective lens to the viewer, typically a relay lens system in the case of rigid endoscopes or a bundle of fiber optics in the case of a fiberscope. an eyepiece. Modern instruments may be video scopes, with no eyepiece. A camera transmits image to a screen for image capture.
- An additional channel to allow entry of medical instruments or manipulators.

The endoscope also has a channel through which surgeons can manipulate tiny instruments, such as forceps, surgical scissors, and suction devices.

- A variety of instruments can be fitted to the endoscope for different purposes.
- A surgeon introduces the endoscope into the body either through a body opening, such as the mouth or the anus, or through a small incision in the skin

- Although fibre-optic endoscopes can be used to visualize the stomach and duodenum, they are unable to reach farther into the small intestine.
- As a result, examination of the small intestine may require the use of wireless capsule endoscopy (video capsule endoscopy), which consists of a pill-sized camera that is swallowed. The camera transmits data to sensors that are attached to the abdomen with adhesive, and a data recorder that stores image information collected by the camera is attached to a belt worn around the waist, the sensors and belt are worn for a period of eight hours, during which time the camera capsule obtains images of nearly the entire length of the small intestine. The images stored in the data recorder are downloaded onto a computer for analysis. The capsule eventually travels the length of the gastrointestinal tract and is excreted in a bowel movement.

## Types

Endoscopy is useful for investigating many systems within the human body; these areas include:

- **Gastrointestinal tract:** esophagus, stomach, and duodenum (esophagogastroduodenoscopy), small intestine (enteroscopy), large intestine/colon (colonoscopy, sigmoidoscopy), bile duct, rectum (rectoscopy), and anus (anoscopy).
- **Respiratory tract:** Nose (rhinoscopy), lower respiratory tract (bronchoscopy).
- **Ear:** Otoscopy
- **Urinary tract:** Cystoscopy
- **Female reproductive tract (gynoscopy):** Cervix (colposcopy), uterus (hysteroscopy), fallopian tubes (fallopscopy).
- **Through a small incision:** Abdominal or pelvic cavity (laparoscopy), interior of a joint (arthroscopy), organs of the chest (thoracoscopy and mediastinoscopy).

## Latest techniques in endoscopy

### Capsule endoscopy

- Capsule endoscopy was developed in the mid-1990s and involves a wireless camera. The camera is small enough to fit into a capsule (roughly the size of a vitamin tablet) and can, therefore, be swallowed.
- As the capsule travels through the digestive tract, it takes thousands of pictures, which are transmitted to a device attached to a wearable belt.
- Capsule endoscopy is used to image the small intestine, a region that is difficult to image using standard endoscopy. It is also very useful for examining the small intestinal mucosa and diagnosing Crohn's disease. The capsule usually passes through the digestive system within 24-48 hours.

### Endoscopic retrograde cholangiopancreatography (ERCP)

ERCP combines X-rays with upper GI endoscopy to diagnose or treat problems with the bile and pancreatic ducts.

### Chromoendoscopy

Chromoendoscopy is a technique that uses a specialized stain or dye on the lining of the intestine during an endoscopy procedure. The dye helps the doctor better visualize if there's anything abnormal on the intestinal lining.

### Endoscopic ultrasound (EUS)

EUS uses an ultrasound in conjunction with an endoscopy. This allows doctors to see organs and other structures that aren't usually visible during a regular endoscopy. A thin needle can then be inserted into the organ or structure to retrieve some tissue for viewing under a microscope. This procedure is called fine needle aspiration.

### Endoscopic mucosal resection (EMR)

EMR is a technique used to help doctors remove cancerous tissue in the digestive tract. In EMR, a needle is passed through the endoscope to inject a liquid underneath the abnormal tissue. This helps separate the cancerous tissue from the other layers so it can be more easily removed.

### Narrow band imaging (NBI)

NBI uses a special filter to help create more contrast between vessels and the mucosa. The mucosa is the inner lining of the digestive tract.

There are three main reasons for carrying out an endoscopy:

- **Investigation:** If an individual is experiencing vomiting, abdominal pain, breathing disorders, stomach ulcers, difficulty swallowing, or gastrointestinal bleeding, for example an endoscope can be used to search for a cause.
- **Confirmation of a diagnosis:** Endoscopy can be used to carry out a biopsy to confirm a diagnosis of cancer or other diseases.
- **Treatment:** an endoscope can be used to treat an illness directly; for instance, endoscopy can be used to cauterize (seal using heat) a bleeding vessel or remove a polyp.



## **MEDICAL THERMOGRAPHY**

- Thermography is the science of visualizing these patterns and determining any deviations from the normal brought about by pathological changes.
- Thermography often facilitates detection of pathological changes before any other method of investigation, and in some circumstances, is the only diagnostic aid available. Radiation hazard as with X-rays. In addition, thermography is a real-time system.

### **Infrared Radiation**

The infrared ray is a kind of electromagnetic wave with a frequency higher than the radio frequencies and lower than visible light frequencies. There are several physical factors which affect the amount of infrared radiation from the human body. These factors are

- Emissivity
- Reflectivity
- Transmittance or absorption.

### **Emissivity**

An object which absorbs all radiation incident upon it, at all wavelengths, is called a black body. A black body is only an idealized case and, therefore, all objects encountered in practice can be termed gray bodies. We thus define the term emissivity as representing the ratio of the radiant energy emitted per unit area by an object to the radiant energy emitted per unit area of the black body at the same temperature.

### **Reflection**

Spectral reflectivity  $r_l$  is defined as the ratio of reflected power to the incident power at a given wavelength.

### **Transmittance and Absorption of Infrared Radiation**

When a semi-transparent body is placed between the surface of any radiation-emitting body and a detector, it is necessary to consider the change in emissivity related to its transmittance, reflectivity and emissivity

### **Infrared Detectors**

Infrared detectors are used to convert infrared energy into electrical signals. Basically, there are two types of detectors:

- Thermal detectors
- Photo-detectors.

Thermal detectors include thermocouples and thermistor bolometers. They feature constant sensitivity over a long wavelength region.

### **Thermographic Equipment's**

Thermographic cameras incorporate scanning systems which enable the infrared radiation emitted from the surface of the skin within the field of view to be focused on to an infrared detector.

The equipment used in thermography basically consists of two units: a special infrared camera that scans the object, and a display unit for displaying the thermal picture on the screen.

The camera is generally mounted on a tripod that is fitted on wheels.

The camera unit contains an optical system which scans the field of view at a very high speed and focuses the infrared radiation on a detector that converts the radiation signal into an electrical signal.

The signal from the camera is amplified and processed before being used to modulate the intensity of the beam in the picture tube. The beam sweeps across the tube face in a pattern corresponding to the scanning pattern of the camera. The picture on the screen can be adjusted for contrast (temperature range) and brightness (temperature level) by means of controls on the display unit.



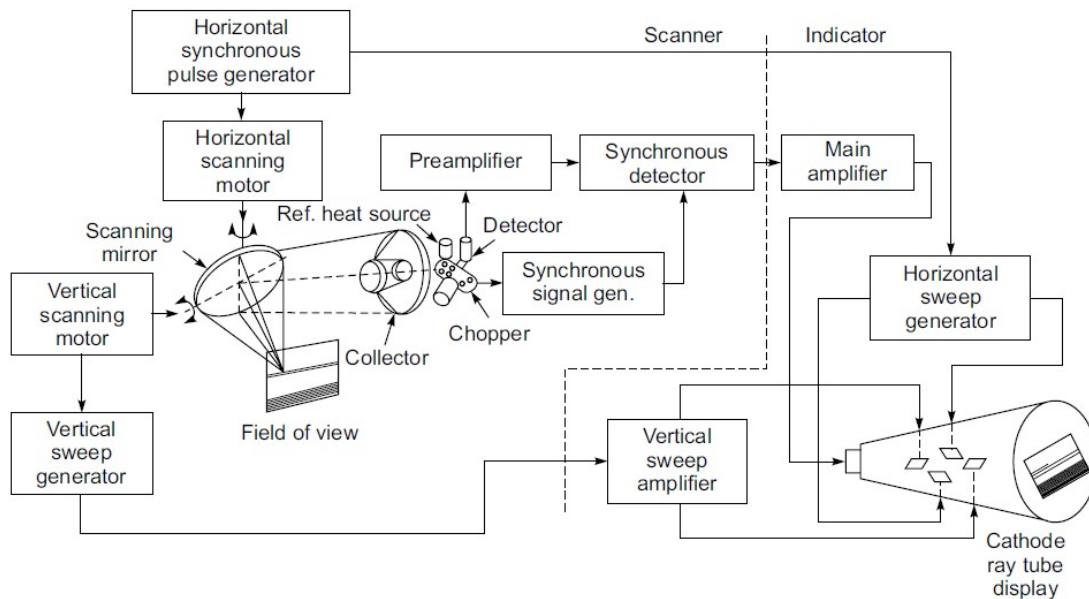

► Fig. 24.6 Block diagram of the scanning and displaying arrangements for infrared imaging

## Recording Techniques

- Quantitative Medical Thermography
- Digital Analysis of Thermograms
- Medical Thermography (digital infrared thermal imaging - DITI ) is used as a method of research for early pre-clinical diagnosis and control during treatment of homeostatic imbalances. There are few devices, which operate in a passive method like infrared Thermography medicine; amongst these are the ECG and EEG. The intrinsic safety of this method makes infrared Thermography free from any limitations or contra- indications.
- Thermography is a non-invasive, non-contact tool that uses the heat from your body to aid in making diagnosis of a host of health care conditions. Thermography is completely safe and uses no radiation.
- Medical Thermography equipment usually has two parts, the IR camera and a standard PC or laptop computer. These systems have only a few controls and relatively easy to use.
- Monitors are high-resolution full colour, isotherm or grey scale, and usually include image manipulation, isothermal temperature mapping, and point-by-point temperature measurement with a cursor or statistical region of interest. The systems measure temperatures ranging from  $10^{\circ}\text{C}$  -  $55^{\circ}\text{C}$  to an accuracy of  $0.1^{\circ}\text{C}$ . Focus adjustment should cover small areas down to  $75 \times 75\text{mm}$ .
- These systems are PC based and therefore able to store tens of thousands of images (and these images may be retrieved for later analysis). The ability to statistically analyse the thermograms at a later date is very important in clinical work. Copies of images can easily be sent (via e-mail, floppy disk, etc.) to referring doctors or other healthcare professionals.
- The medical applications of DITI are extensive, particularly in the fields of Rheumatology, Neurology, Oncology, Physiotherapy and sports medicine. Thermal imaging systems are an economical easy-to-use tool for examining and monitoring patients quickly and accurately.
- Utilising high-speed computers and very accurate thermal imaging cameras, the heat from your body is processed and recorded in the computer into an image map which can then be analysed on screen, printed or sent via email.

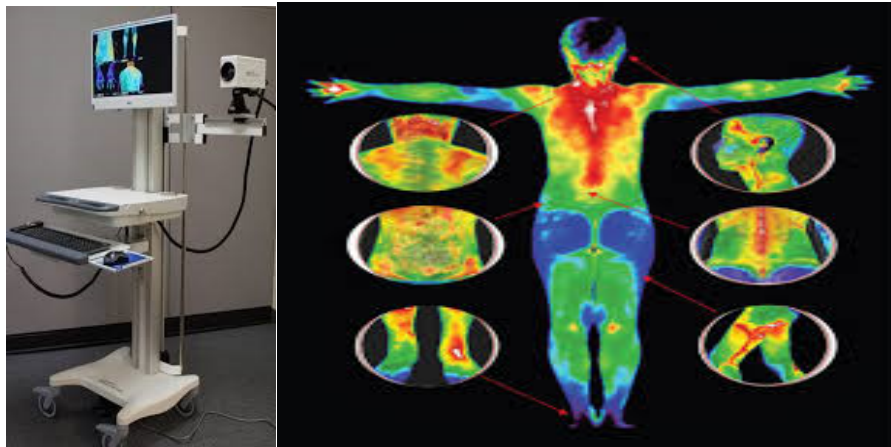

- A doctor can then use the image map to determine if abnormal hot or cold areas are present. These hot and cold areas, can relate to a number of conditions for which the Food and Drug Administration, Bureau of Medical Devices has approved the thermography procedure. These include, the screening for breast cancer, extra-cranial vessel disease (head and neck vessels), neuro-Musculo-skeletal disorders and vascular disease of the lower extremities.
- The human body absorbs infrared radiation almost without reflection, and at the same time, emits part of its own thermal energy in the form of infrared radiation. The intensity of this radiant energy corresponds to the temperature of the radiant surface. It is, therefore, possible to measure the varying intensity of radiation at a certain distance from the body and thus determine the surface temperature.
- In a normal healthy subject, the body temperature may vary considerably from time to time, but the skin temperature pattern generally demonstrates characteristic features, and a remarkably consistent bilateral symmetry.

Applications of Thermography are in:

- Breast pathologies
- Extra-Cranial Vessel Disease
- Neuro-Musculo-Skeletal
- Vertebrae (nerve problems/arthritis)
- Lower Extremity Vessel Disease

### **Biotelemetry systems**

Biotelemetry is the use of telemetry methods in order to remotely observe, document, and measure certain physiological functions in human beings or other living organisms. The field consists of several subfields, including medical and human research telemetry, animal telemetry, and implantable biotelemetry. Medical telemetry is of particular importance because it can be used to remotely track the vital signs of ambulatory patients.

Measurements which have been done in biotelemetry can be determined in two categories:

Bioelectrical variables, such as electrocardiogram (ECG), electromyogram (EMG) and electroencephalogram (EEG).

Physiological variables that require transducers, such as blood pressure, gastrointestinal pressure, blood flow and temperature. By using suitable transducers, telemetry can be employed for the measurement of a wide variety of physiological variables.

### **Elements of Telemetry**

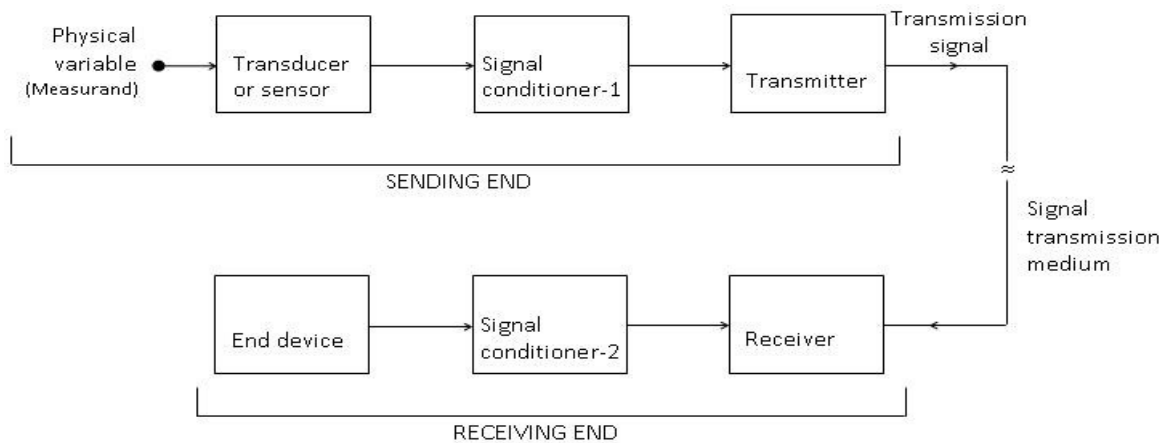

**Block schematic of basic telemetry system**

### 1. Transducer or Sensor:

- Converts the physical variable to be telemetered into an electrical quantity.

### 2. Signal Conditioner-1:

- Converts the electrical output of the transducer (or sensor) into an electrical signal compatible with the transmitter.

### 3. Transmitter:

Its purpose is to transmit the information signal coming from the signal conditioner-1 using a suitable carrier signal to the receiving end.

The transmitter may perform one or more of the following functions:

- **Modulation:** Modulation of a carrier signal by the information signal.
- **Amplification:** As and if required for the purpose of transmission.
- **Signal Conversion:** As and if required for the purpose of transmission.
- **Multiplexing:** If more than one physical variable needs to be telemetered simultaneously from the same location, then either frequency-division multiplexing (FDM) or time-division multiplexing (TDM) is used.
- **Receiver:** Its purpose is to receive the signal(s) coming from the transmitter (located at the sending end of the telemetry system) via the signal transmission medium and recover the information from the same.
- It may perform one or more of the following functions:
  1. Amplification
  2. Demodulation:
  3. Reverse Signal Conversion
- **De-multiplexing**
- **Signal Conditioner-2:** Processes the receiver output as necessary to make it suitable to drive the given end device.
- **End Device:** The element is so called because it appears at the end of the system.
- End device may be performing one of the following functions:
  1. Analog Indication:
  2. Digital Display

## Single Channel Telemetry Systems

In a majority of the situations requiring monitoring of the patients by wireless telemetry, the parameter which is most commonly studied is the electrocardiogram. It is known that the display of the ECG and cardiac rate gives sufficient information on the loading of the cardiovascular system of the active subjects.

### ECG Telemetry System

- The Telemetry Transmitter which consists of an ECG amplifier, a sub-carrier oscillator and a UHF transmitter along with dry cell batteries.
- Telemetry Receiver consists of a high frequency unit and a demodulator, to which an electrocardiograph can be connected to record, a cardio scope to display and a memory device to store the ECG. A heart rate meter with an alarm facility can be provided to continuously monitor the beat-to-beat heart rate of the subject.

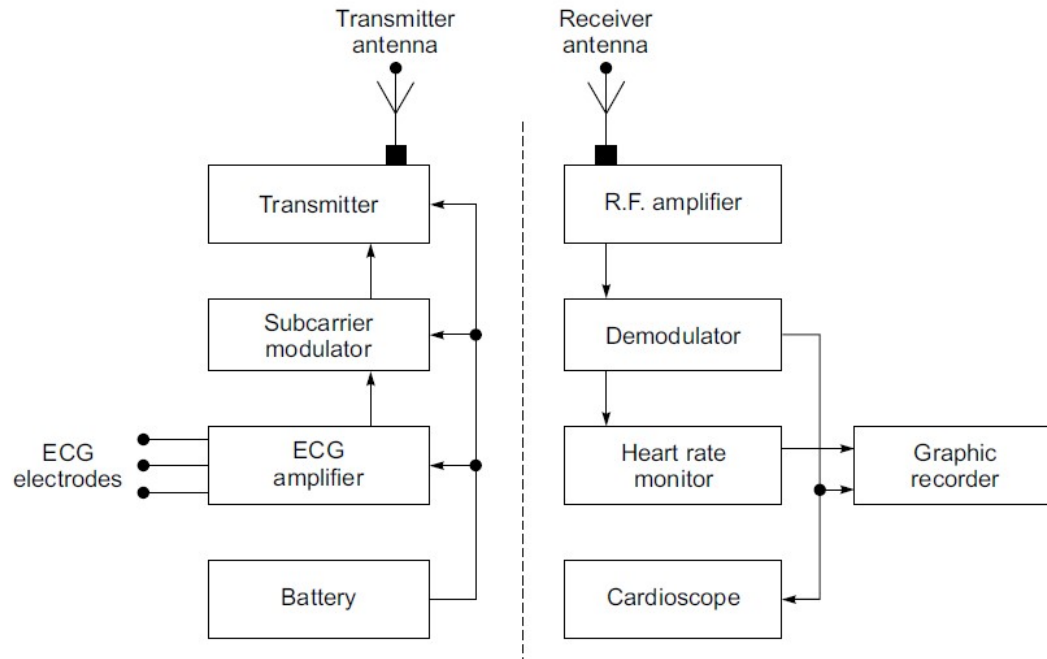

► Fig. 11.6 Block diagram of a single channel telemetry system

- While monitoring paced patients for ECG through telemetry, it is necessary to reduce pacemaker pulses. The amplitude of pacemaker pulses can be as large as 80 mV compared to 1–2 mV, which is typical of the ECG. The ECG amplifiers in the transmitter are slew rate (rate of change of output) limited so that the relatively narrow pacemaker pulses are reduced in amplitude substantially.
- Some ECG telemetry systems operate in the 450–470 MHz band, which is well-suited for transmission within a hospital and has the added advantage of having a large number of channels available.
- The ECG signal, picked up by three pre-gelled electrodes attached to the patient's chest, is amplified and used to frequency modulate a 1 kHz sub-carrier that in turn frequency-modulates the UHF carrier. The resulting signal is radiated by one of the electrode leads (RL), which serves as the antenna. The input circuitry is protected against large amplitude pulses that may result during defibrillation.

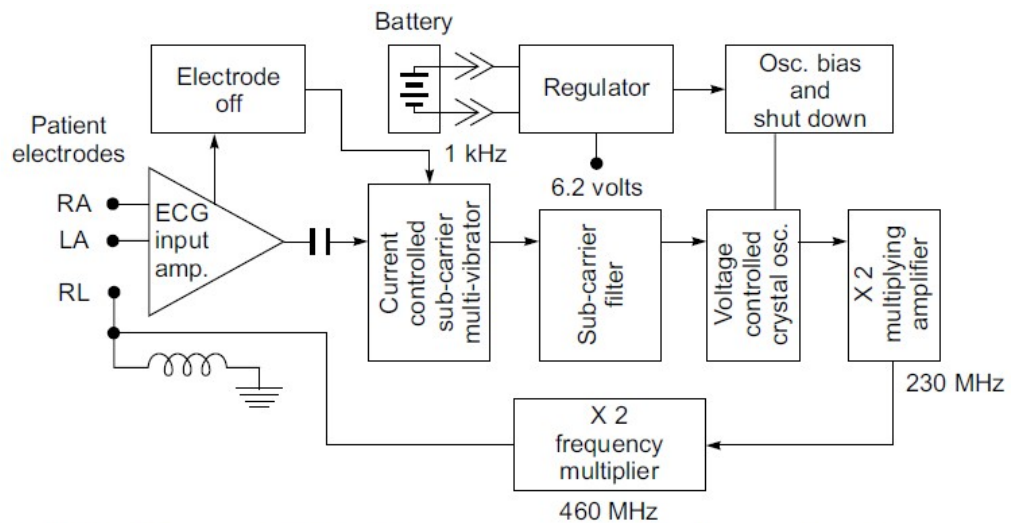

► Fig. 11.7 Block diagram of ECG telemetry transmitter (Redrawn after Larsen et al permission of Hewlett Packard, U.S.A.)

### MULTI-CHANNEL WIRELESS TELEMETRY SYSTEMS

- Medical measuring problems often involve the simultaneous transmission of several parameters. For this type of application, a multi-channel telemetry system is employed. Multi-channel telemetry is particularly useful in athletic training programs as it offers the possibility of simultaneously surveying several physiological parameters of the person being monitored. With appropriate electrodes/transducers and preamplifiers, the multi-channel systems permit the transmission of the following parameters simultaneously depending upon the number of channels required: ECG and heart rate, respiration rate, temperature, intravascular and intra-cardiac blood pressure.
- In multi-channel telemetry, the number of sub-carriers used is same as the number of signals to be transmitted. Each channel therefore has its own modulator. The RF unit—the same for all channels—converts the mixed frequencies into the transmission band. Similarly, the receiver unit contains the RF unit and one demodulator for each channel.
- Pulse width modulation is better suited for multi-channel biotelemetry systems. Such systems are insensitive to carrier frequency shifts and have high noise immunity. FM-FM systems for similar use may have low power consumption and high baseline stability, but they are more complicated and turn out to be more expensive. They can be troubled by interference between different channels. Techniques for separation usually require expensive and complex filters and even with these, cross-talk can still be a problem. Similarly, pulse-position amplitude modulation easily gets into synchronization difficulties caused by noise and thus results in a loss of the information transmitted. On the other hand, advantages of pulse-width modulation include lower sensitivity to temperature and battery voltage changes and its adaptability to miniaturization due to availability of suitable integrated circuits.
- For multi-channel radiotelemetry, various channels of information are combined into a single signal. This technique is called multiplexing.

There are two basic methods of multiplexing these are:

- Frequency-division multiplexing: The method makes use of continuous-wave sub-carrier frequencies. The signals frequency-modulate multiple subcarrier oscillators, each being at such a frequency that its modulated signal does not overlap the frequency spectra of the other modulated signals. The frequency modulated signals from all channels are added together through a summing amplifier to give a composite signal in which none of the parts overlap in frequency. This signal then modulates the RF carrier of the transmitter and is broadcast.
- Time-division multiplexing: In this technique, multiple signals are applied to a commutator circuit. This circuit is an electronic switch that rapidly scans the signals from different channels. An oscillator drives the commutator circuit so that it samples each signal for

an instant of time, thereby giving a pulse train sequence corresponding to input signals. A frame reference signal is also provided as an additional channel to make it easy to recognize the sequence and value of the input channels.

### Telemetry of ECG and Respiration

An FM-FM modulated radiotelemetry transmitter for detecting and transmitting ECG and respiration activity simultaneously on a single carrier frequency in the FM broadcast band. Respiration is detected by the impedance pneumographic principle by using the same pair of electrodes that are used for the ECG.

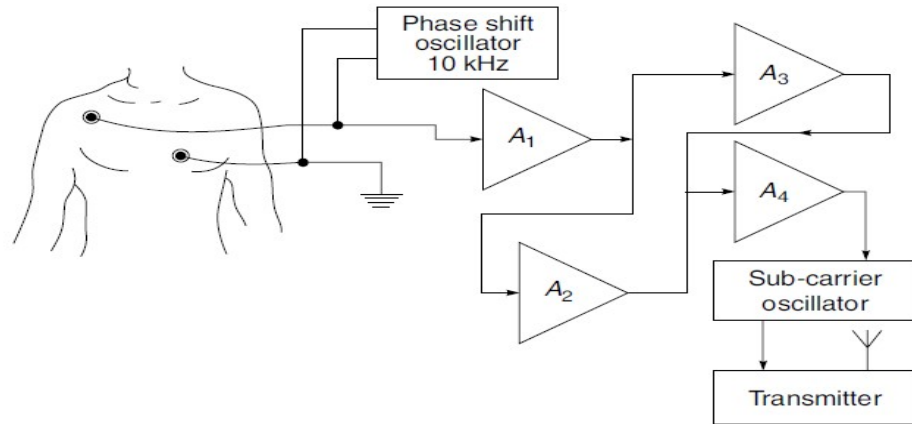

### Obstetrical Telemetry System

There has been a great deal of interest to provide greater freedom of movement to patients during labour while the patient is continuously monitored through a wireless link. Thus, from a central location, it is possible to maintain a continuous surveillance of cardiocogram records for several ambulatory patients. In the delivery room, telemetry reduces the encumbering instrumentation cables at the bedside. Moreover, when an emergency occurs, there is no loss of monitoring in the vital minutes needed for patient transfer.

The patient carries a small pocket-sized transmitter which is designed to pick up signals for foetal heart rate and uterine activity. The foetal heart rate is derived from foetal ECG which is obtained via a scalp electrode attached to the foetus after the mother's membranes are ruptured.

Uterine activity is measured via an intra-uterine pressure transducer. If only foetal ECG is measured, the patient herself can indicate uterine activity or foetal movement by using a handheld push button.

The receiver located away from the patient, is connected to a conventional cardiocograph. If the patient exceeds the effective transmission range or the electrode has a poor contact, it is appropriately transmitted for corrective action.



### MULTI-PATIENT TELEMETRY

- The establishment of instrumented coronary care units has resulted in substantial reduction in the mortality rates of hospitalized patients. When a patient's condition has stabilized within a few days, it is necessary that he is monitored during the early stages of increased activity and exertion to determine if his heart has sufficiently recovered. This can be conveniently done by the use of telemetry which provides a sort of intermediate stage of care that smoothens the



patient's transition back to a normal life. It thus permits surveillance of suspected coronaries without the unnatural constraints of confining the patient to bed.

- The main advantage of a multi-patient single parameter telemetry system is that patients making satisfactory recovery can vacate the hard-wired instrument beds in the ICU/CCU units, which provides a positive psychological effect. The patients regain mobility after an extended period of confinement thereby improving their muscle tone and circulation. Transmitters as small in size and weighing less including battery are commercially available. Data from different patients is received at the nurse's central station. The station may have the facility of non-fade display of received waveforms, an ECG recorder which gets activated when the patient goes into alarm, loose lead/loss of signal alarm.

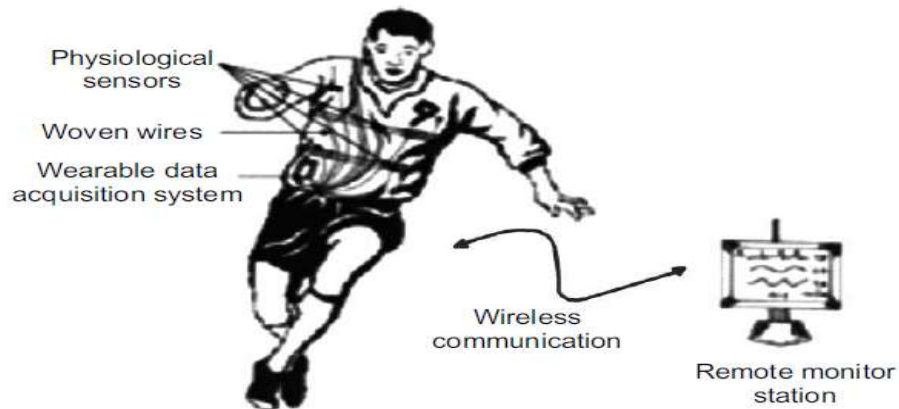

### **Implantable Telemetry Systems**

Implantable telemetry systems allow the measurement of multiple physiological variables over long periods of time without any attachment of wires, restraint or anaesthesia to the monitored subjects, no sensors need to be attached even to the body surface. Most of the work in implantable telemetry has been used exclusively in animal research. Single or multi-channel systems have been used successfully to monitor ECG, EEG, blood pressure, blood flow, temperature, etc.

### **Retinal Imaging**

Light from very low-power lasers or a camera flash enters the eye through the pupil. Light reflected back leaves the same way to be collected by the machine creating an image of the retina. Similar types of imaging are performed at a high street optician for a standard eye health check-up. However, we analyse these images in more detail to see what other information they could reveal about the health of human body and brain.

Retinal imaging takes a digital picture of the back of your eye. It shows the retina (where light and images hit), the optic disk (a spot on the retina that holds the optic nerve, which sends information to the brain), and blood vessels. This helps your optometrist or ophthalmologist find certain diseases and check the health of your eyes.

Doctors have long used a tool called an ophthalmoscope to look at the back of your eye. Retinal imaging allows doctors to get a much wider digital view of the retina. It doesn't replace a regular eye exam, but adds another layer of precision to it.





The back of the eye is called the retina and is one of the few places in the human body allowing easy observation of blood vessels and nerves. These anatomical structures are shared with the brain, but where they are much less accessible. Subtle changes in the retina may reflect similar processes happening and these early signs may precede declining brain health by years or even decades. Studying blood vessels in the eye is also useful in detecting and understanding diseases that affect the human circulatory system such as high blood pressure, diabetes and heart disease. For example, with further research, we may soon be able to identify people with undiagnosed high blood pressure through pictures of their retina, thus enabling a doctor to prescribe appropriate medication and considerably reduce their risk of having a future heart attack or stroke

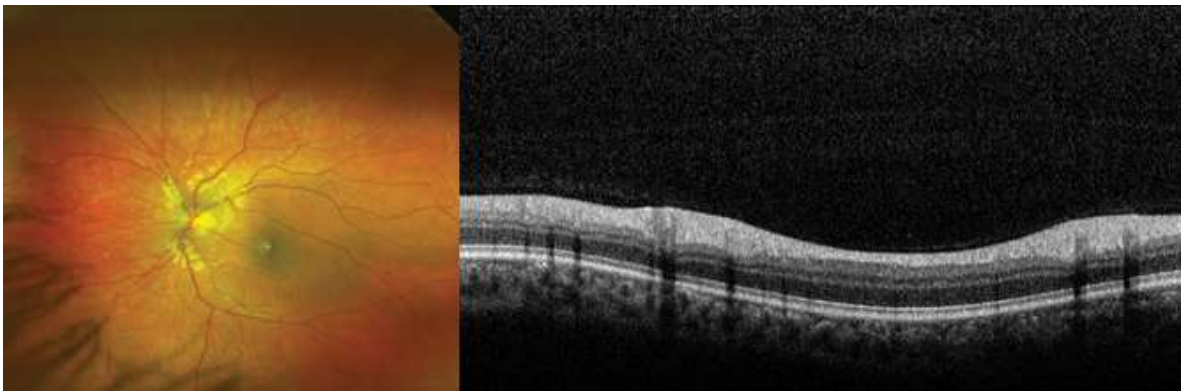

Retinal images can be compared side-by-side over time to monitor your eye health and detect subtle changes. They allow your doctor to explain treatment more thoroughly as you can review the images together, which ensures a certain level of precision to your routine eye exam.

### **Techniques**

Retinal imaging has continuously improved through consistent research and development over the years. There are a few different methods that your optometrist can use to inspect your eye.

- Optical Coherence Tomography
- Fundus Photography
- Angiography

### **Optical Coherence Tomography**

- Optical coherence tomography (OCT) is a non-invasive imaging test. OCT uses light waves to take cross-section pictures of your retina.
- With OCT, ophthalmologist can see each of the retina's distinctive layers. This allows your ophthalmologist to map and measure their thickness. These measurements help with diagnosis.

They also provide treatment guidance for glaucoma and diseases of the retina. These retinal diseases include age-related macular degeneration (AMD) and diabetic eye disease.

- OCT is often used to evaluate disorders of the optic nerve as well. The OCT exam helps your ophthalmologist see changes to the fibers of the optic nerve. For example, it can detect changes caused by glaucoma.
- OCT relies on light waves. It cannot be used with conditions that interfere with light passing through the eye. These conditions include dense cataracts or significant bleeding in the vitreous.

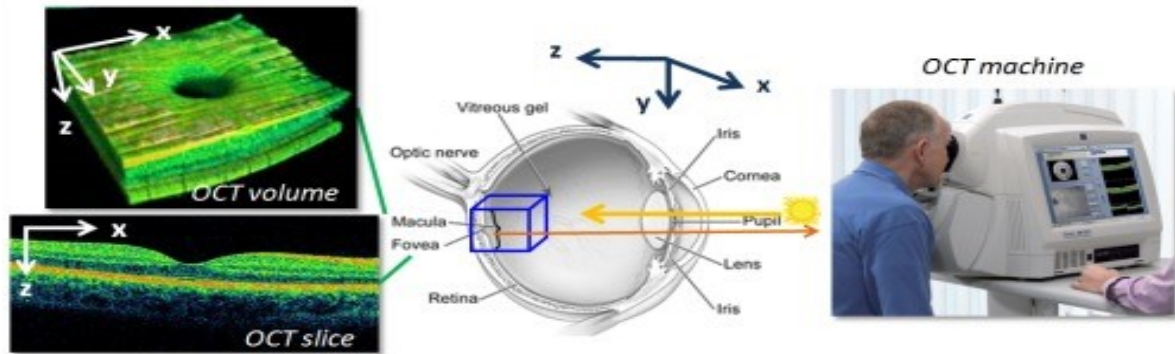

### Fundus Photography

- The fundus is the back of the eye and includes the retina, optic nerve, and retinal blood vessels. In fundus photography, the fundus is photographed with special cameras through a dilated pupil, providing a colour picture of the back of the eye. The procedure is brief, only taking a minute or two, and painless.
- It's able to provide a picture of the retina, the retinal vasculature (blood vessels), and the optic nerve head, where retinal blood vessels enter the eye. It can also show drusen, abnormal bleeding, scar tissue, and areas of atrophy. In sum, it can provide your eye doctor with a visual picture of any abnormalities that may be present in the back of the eye.
- In terms of macular degeneration, fundus photography may reveal the extent of the disease at that moment. This is especially important as the disease progresses – a series of fundus photographs can provide your doctor with a visual timeline of how it has affected your eye, as well as the severity and speed of the progression. Fundus photography is also used in other eye diseases, such as diabetic retinopathy and glaucoma.



### Angiography

**Fluorescein Angiography (FA)** is a diagnostic procedure that uses a special camera to record the blood flow in the RETINA – the light sensitive tissue at the back of the eye. The test does not involve any direct contact with the eyes. Your eyes will be dilated before the procedure. Fluorescein dye is injected into a vein in the arm/hand. As dye passes through the blood vessels of your eye, photographs are taken to record the blood flow in your retina. The photographs can reveal abnormal blood vessels or damage to the lining underneath the retina. The images will be captured in black and white. The dye will fluoresce in the blood vessels and be recorded as light grey or white in the image. Interpretation of the abnormal angiogram relies on the identification of areas that exhibit hypo fluorescence (darkness) or hyper fluorescence (brightness).

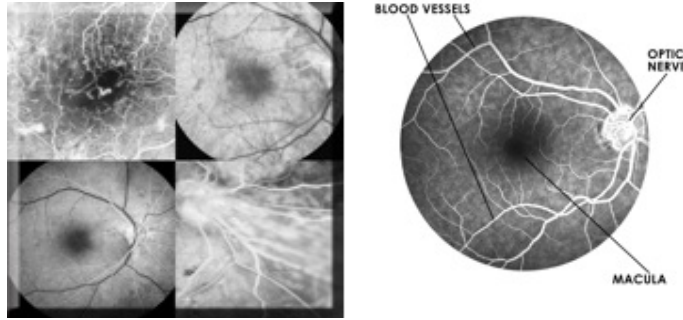

### **Who Needs Retinal Imaging?**

Retinal imaging into an eye exam may be necessary if you have certain conditions.

- Diabetes can damage blood vessels in your eyes, which can cause loss of sight if not managed.
- Macular degeneration can occur with age, which causes sight to become blurry.
- Glaucoma damages the optic nerve due to fluid build-up in the eye and may cause vision loss.

### **Imaging application in Biometric systems**

Images have a huge share in this era of information. In biometrics, image processing is required for identifying an individual whose biometric image is stored in the database previously. Faces, fingerprints, irises, etc., are image-based biometrics, which require image processing and pattern recognition techniques. For an image based biometric system to work accurately, it needs to have the sample image of user's biometric in a very clear and non-adulterated form.

#### **Requirement of Image Processing in Biometrics**

The image of user's biometric is fed into the biometric system. The system is programmed to manipulate the image using equations, and then store the results of the computation for each pixel. To selectively enhance certain fine features in the data and to remove certain noise, the digital data is subjected to various image processing operations. Image processing methods can be grouped into three functional categories –

#### **Image Restoration**

Image restoration mainly includes –

- Reducing noise introduced in the image at the time of acquiring sample.
- Removing distortions appeared during enrolment of biometric.

Image smoothing reduces noise in the image. Smoothing is carried out by replacing each pixel by the average value with the neighbouring pixel. The biometric system uses various filtering algorithms and noise reduction techniques such as Median Filtering, Adaptive Filtering, Statistical Histogram, Wavelet Transforms, etc.

#### **Image Enhancement**

Image enhancement techniques improve the visibility of any portion or feature of the image and suppress the information in other parts. It is done only after restoration is completed. It includes brightening, sharpening, adjusting contrast, etc., so that the image is usable for further processing.

#### **Feature Extraction**

Two types of features are extracted from image, namely –

- **General features** – The features such as shape, texture, color, etc., which are used to describe content of the image.
- **Domain-specific features** – They are application dependent features such as face, iris, fingerprint, etc. Gabor filters are used to extract features.



When the features are extracted from the image, you need to choose a suitable classifier. The widely used classifier Nearest Neighbour classifier, which compares the feature vector of the candidate image with the vector of the image stored in the database.

**B-Splines** are approximations applied to describe curve patterns in fingerprint biometric systems. The coefficients of B-Splines are used as features. In case of iris recognition system, the images of iris are decomposed using Discrete Wavelet Transform (DWT) and the DWT coefficients are then used as features.

#### POST MCQ:

1. Currently available oximeters utilize \_\_\_\_\_ wavelengths.
  - a) Equal to 2
  - b) Cannot be determined
  - c) Less than 2
  - d) More than 2
 Answer: d
  
2. \_\_\_\_\_ System may include lenses, mirrors, slits, diaphragm etc.
  - a) Photo system
  - b) Radiant system
  - c) Cardiac system
  - d) Optical system
 Answer: d
  
3. The CMRR is expressed in \_\_\_\_\_
  - a) V/s
  - b) dB/ms
  - c) dB/s
  - d) dB
 Answer: d
  
4. Reduction in electromagnetic coupling is achieved by \_\_\_\_\_
  - a) Shielding
  - b) Common grounding
  - c) Multiple grounding
  - d) Wire twisting
 Answer: c
  
5. From the options given below select the one which is not a type of isolation amplifier?
  - a) Transformer type isolation amplifiers
  - b) Resistive coupled isolation amplifiers
  - c) Optically isolated isolation amplifiers
  - d) Capacitively coupled isolation amplifiers
 Answer: b

**UNIT- V**  
**LIFE ASSISTING, THERAPEUTIC AND ROBOTIC DEVICES**

**AIM**

To study about medical assistance techniques and therapeutic equipment's.

**PRE MCQ:**

1. In which one of the following year, the cardiac pacemaker was invented by an electrical engineer?
  - a) 1940
  - b) 1910
  - c) 1950
  - d) 1989Answer: b
2. The first cardiac pacemaker was invented by a Canadian electrical engineer named as
  - a) Sir Elie Franklin Burton
  - b) Sir Cecil Hall
  - c) Dr John A. Hopps
  - d) Sir Barbara BainAnswer: b
3. The commonest source of energy for pacemaker is
  - a) Mercury battery
  - b) The ordinary dry cell
  - c) Nuclear battery
  - d) Solar cellAnswer: a
4. Inflammation of the kidneys is called
  - a) Otitis
  - b) Hepatitis
  - c) Reprhritis
  - d) ToxaemiaAnswer: c
5. In the case of stable total AV block, a pacemaker is chosen
  - a) With constant frequency
  - b) That is atrial synchronous
  - c) That is ventricular synchronous
  - d) With variable frequency and synchronisation with ventricular actionAnswer: a

**THEORY:**

**Pacemakers**

A device capable of generating artificial pacing impulses and delivering them to the heart is known as a pacemaker system (commonly called a pacemaker). It consists of pulse generator and appropriate electrodes.

- The rhythmic beating of the heart is due to the triggering pulses that originate in an area of specialized tissue in the right atrium of the heart. This area is known as the Sino-atrial node.
- In abnormal situations, if this natural pacemaker ceases to function or becomes unreliable or if the triggering pulse does not reach the heart muscle because of blocking by the damaged tissues, the natural and normal synchronization of the heart action gets disturbed.
- When monitored, this manifests itself through a decrease in the heart rate and changes in the electrocardiogram (ECG) waveform.
- By giving external electrical stimulation impulses to the heart muscle, it is possible to regulate the heart rate. These impulses are given by an electronic instrument called a 'pacemaker'



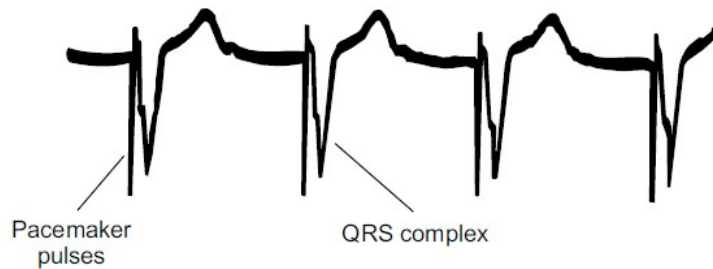

► Fig. 25.1 Pacemaker pulses followed by QRS complex of the heart

A pacemaker basically consists of two parts:

- (i) an electronic unit which generates stimulating impulses of controlled rate and amplitude, known as pulse generator
- (ii) the lead which carries the electrical pulses from the pulse generator to the heart. The lead includes the termination which connects to the pulse generator and the insulated conductors, which interface with electrodes and terminate within the heart.

## Types of Pacemakers

### 1. Internal Pacemakers:

- In this entire system is inside the body.
- Permanently implanted in the body whose SA node failed to function properly.
- The system is implanted with the pulse generator placed in a surgically formed pocket below the right or left cavicle.
- Internal leads connected to electrodes that directly contact surface of myocardium. Pulse generator must be self-contained with a power source capable of continuously operating the unit for a period of years.

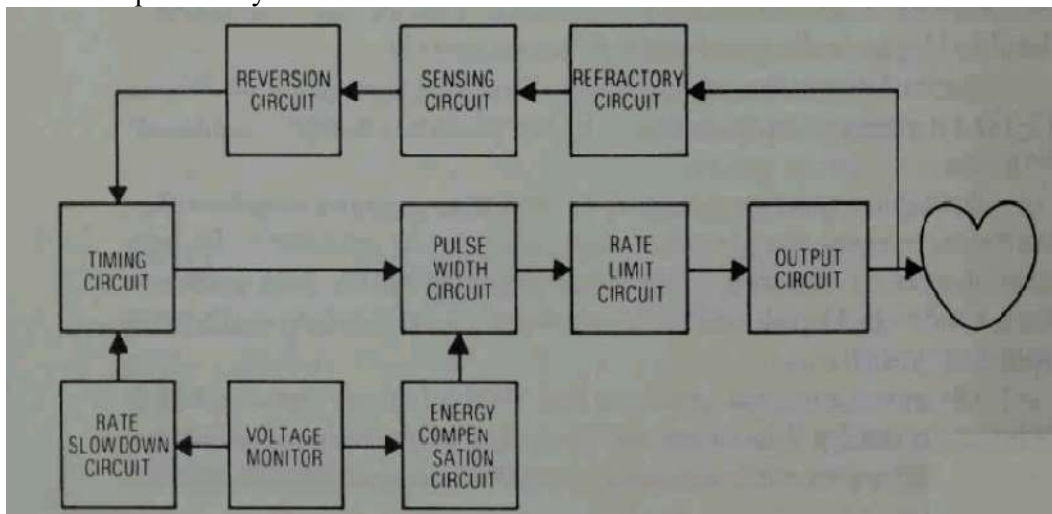

Above fig shows an RC, reference voltage source, and a comparator determines the basic pacing rate of the pulse generator.

- Its output signal feeds into a second RC network, the pulse width circuit, which determines the stimulating pulse duration.
- A third RC network, the rate-limiting circuit, disables the comparator for a pre-set interval and thus limits the pacing rate to a maximum of 120 pulses per minute for most dagger-component failures.
- The output circuit provides a voltage pulse to stimulate the heart. The voltage monitor circuit senses cell depletion and the rate slowdown circuit and energy compensation circuit of this event.

- The rate slowdown circuit shuts off some of the current to the basic timing network to cause the rate to slow down  $8 \pm 3$  beats per minute when cell depletion has occurred. The energy-compensation circuit causes the pulse duration to increase as the battery voltage decreases, to maintain nearly constant stimulation energy to the heart.
- There is also a feedback loop from the output circuit to the refractory circuit, which provides a period of time following an output pulse or a sensed R-wave during which the amplifier will not respond to outside signals.

The sensing circuit detects a spontaneous R wave and resets the oscillator timing capacitor. The reversion circuit allows the amplifier to detect a spontaneous R wave in the presence of low-level continuous wave interference. In the absence of an R wave, this circuit allows the oscillator to pace at its present rate  $\pm 1$  beat per minute.

## 2. External Pacemakers

- Employed to restart normal rhythm of heart in case of cardiac standstill.
- An external pacemaker usually consists of an externally worn pulse generator connected to electrodes located on or within the myocardium.
- Used on patients with temporary heart irregularities.
- In this the pulse generator located outside the body and connected to ventricle using along thin tube called catheter.
- The pacing impulse (80 mA) is applied through metal electrodes placed on the surface of the body.

## Types of Pacing Modes

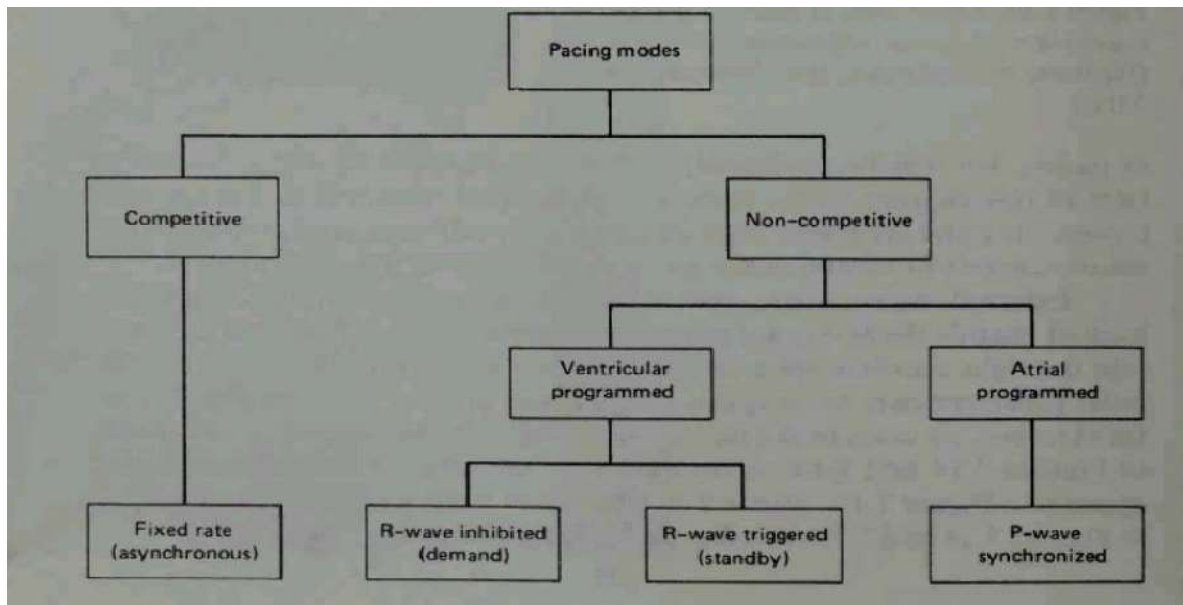

The non-competitive method, which uses pulse generators that are either ventricular programmed or programmed by the atria, is more popular. Ventricular-programmed pacemakers are designed to operate either in a demand (R-wave-inhibited) or standby (R-wave-triggered) mode, whereas atrial-programmed pacers are always synchronized with the P wave of the ECG.

### 1. Competitive [Fixed Rate or Asynchronous Pacemaker]

- The first (and simplest) pulse generators were *fixed-rate* or *asynchronous* devices that produced pulses at a fixed rate and were independent of any natural cardiac activity:
- A synchronous pacing is called *competitive* pacing because the fixed-rate impulses may occur along with natural pacing impulses generated by the heart and would therefore, be in competition with them in controlling the heartbeat. This competition is largely eliminated through use of ventricular or atrial-programmed pulse generators.



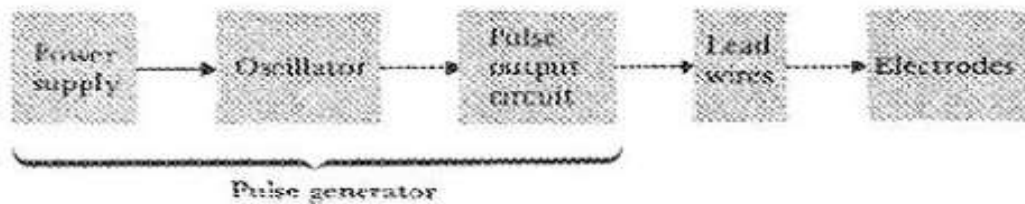

Block diagram of an asynchronous cardiac pacemaker

## 2. Ventricular Programmed

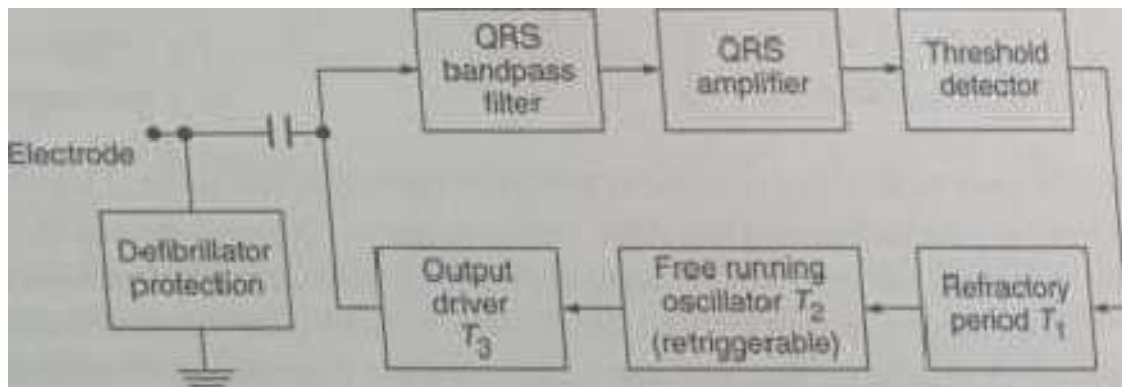

- The problems of shorter battery life and competition for control of the heart led, in part, to the development of ventricular-programmed (demand or standby) pulsegenerators.
- Either type of ventricular-programmed pulse generator, when connected to the ventricles via electrodes, is able to sense the presence (or. absence) of a naturally occurring R wave.
- The pulse generator has two functions, viz., pacing and sensing. Sensing is accomplished by picking up the ECG signal.
- In the case of dual-chamber pacing, the P wave is also sensed.
- Once the signal enters the sensing circuit, it is passed through a QRS bandpass filter. This filter is design to pass signal components in the frequency range of 5-100 Hz, with a centre frequency of 30 Hz. This is followed by an amplifier and threshold detector which is designed to operate with a detection sensitivity of 1-2 mV. Sensitivity of this order ensures reliable detection of cardiac signals sensed on the electrodes which typically have amplitudes in the 1-30 mV range depending onto 1 electrode surface area and the sensing circuit loading impedance.
- Refractory period ( $T_1$ ) is necessarily incorporated to limit the pulse delivery rate particularly in the ' presence of electromagnetic interference. It is meant to prevent multiple re-triggering of the astable multivibrator following a sensed or paced contraction.
- The free-running multivibrator provides a fixed rate mode with an interval of  $T_2$  via the output driver circuit. The output pulses of a length  $T_3$  synchronous with input signals that fall outside the sensing refractory period  $T_1$  are thus delivered at the stimulating electrodes.

### R-wave-inhibited (demand):

- The output of an R-wave-inhibited (demand) unit is suppressed (no output pulses are reproduced) as long as natural (intrinsic) R waves are present. Thus, its output is held back or inhibited when the heart is able to pace itself.
- However, should standstill occur, or should the intrinsic rate fall below the preset rate of the pacer (around 70 BPM), the unit will automatically provide an output to pace the heart after an escape interval at the designated rate.

- In this way, ventricular-inhibited pacers are able to pace on demand.
- A demand pacer, in the absence of R waves, automatically reverts to a fixed-rate mode of operation.

#### **R-wave- triggered:**

- R-wave-triggered pulse generators, like the inhibited units, sense each intrinsic R wave. However, this pacer emits an impulse with the occurrence of each sensed R wave. Thus, the unit is triggered rather than inhibited by each R wave.
- The pacing impulses are transmitted to the myocardium during its absolute refractory period, so they will have no effect on normal heart activity.

### **3. Atrial Programmed**

- In cases of complete heart block where the atria are able to depolarize but the impulse fails to depolarize the ventricles, atrial synchronous pacing may be used. Here the pulse generator is connected through wires and electrodes to both the atria and the ventricles.
- The atrial electrode couples atrial impulses to the pulse generator, which then emits impulses to stimulate the ventricles via the ventricular electrode. In this way, the heart is paced at the same rate as the natural pacemaker.
- When the SA node rate changes because of vagus or sympathetic neuronal control, the ventricle will change its rate accordingly but not above some maximum rate (about 125 per minute).

## **CARDIAC DEFIBRILLATORS**

### **NEED FOR A DEFIBRILLATOR**

- Ventricular fibrillation is a serious cardiac emergency resulting from asynchronous contraction of the heart muscles. This uncoordinated movement of the ventricle walls of the heart may result from coronary occlusion, from electric shock or from abnormalities of body chemistry.
- Because of this irregular contraction of the muscle fibres, the ventricles simply quiver rather than pumping the blood effectively. This results in a steep fall of cardiac output and can prove fatal if adequate steps are not taken promptly.
- In fibrillation, the main problem is that the heart muscle fibres are continuously stimulated by adjacent cells so that there is no synchronised succession of events that follow the heart action. Consequently, control over the normal sequence of cell action cannot be captured by ordinary stimuli.

### **DEFIBRILLATOR**

- Ventricular fibrillation can be converted into a more efficient rhythm by applying a high energy shock to the heart. This sudden surge across the heart causes all muscle fibres to contract simultaneously. Possibly, the fibres may then respond to normal physiological pacemaker pulses. The instrument for administering the shock is called a defibrillator.



### **Restoration of normal rhythm in fibrillating heart as achieved by direct current shock**

The shock can be delivered to the heart by means of electrodes placed on the chest of the patient (external defibrillation) or the electrodes may be held directly against the heart when the chest is open (internal defibrillation). Higher voltages are required for external defibrillation than for internal defibrillation.

## **DC DEFIBRILLATOR**

### **Basic Principle**

In this an energy storage capacitor is charged at a relatively slow rate (in the order of seconds) from the AC line by means of a step-up transformer and rectifier arrangement or from a battery and a DC to DC converter arrangement. During defibrillation, the energy stored in the capacitor is then delivered at a relatively rapid rate (in the order of milliseconds) to the chest of the subject. For effective defibrillation, it is advantageous to adopt some shaping of the discharge current pulse. The simplest arrangement involves the discharge of capacitor energy through the patient's own resistance (R). This yields an exponential discharge typical of an RC circuit. If the discharge is truncated, so that the ratio of the duration of the shock to the time constant of decay of the exponential waveform is small, the pulse of current delivered to the chest has a nearly rectangular shape. For a somewhat larger ratio, the pulse of current appears nearly trapezoidal. Rectangular and trapezoidal waveforms have also been found to be effective in the trans-thoracic defibrillation and such waveforms have been employed in defibrillators designed for clinical use.

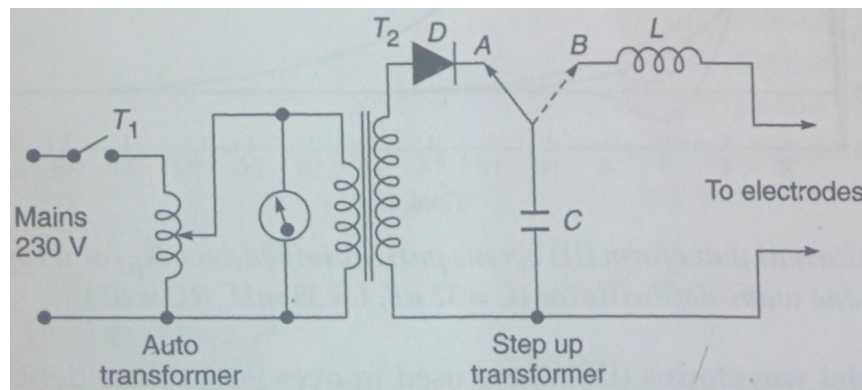

- A variable auto-transformer  $T_1$  forms the primary of a high voltage transformer  $T_2$ . The output voltage of the transformer is rectified by a diode rectifier and is connected to a vacuum type high voltage change-over switch. In position A, the switch is connected to one end of an oil-filled 16 micro-farad capacitor.
- In this position, the capacitor charges to a voltage set by the positioning of the autotransformer. When the shock is to be delivered to the patient, a foot switch or a push button mounted on the handle of the electrode is operated. The high voltage switch changes over to position 'B' and the capacitor is discharged across the heart through the electrodes.
- In a defibrillator, an enormous voltage (approx. 4000 V) is initially applied to the patient.

#### **Discharging Pulse of a DC defibrillator**

- The most common waveform utilized in the RLC circuit employs an under-damped response with a damping factor less than unity.
- This particular waveform is called a 'Lown' waveform. This waveform is more or less of an oscillatory character, with both positive and negative portions. The pulse width in this waveform is defined as the time that elapses between the start of the impulse and the moment that the current intensity passes the zero line for the first time and changes direction.
- The pulse duration is usually kept as 5 ms or 2.5 ms.

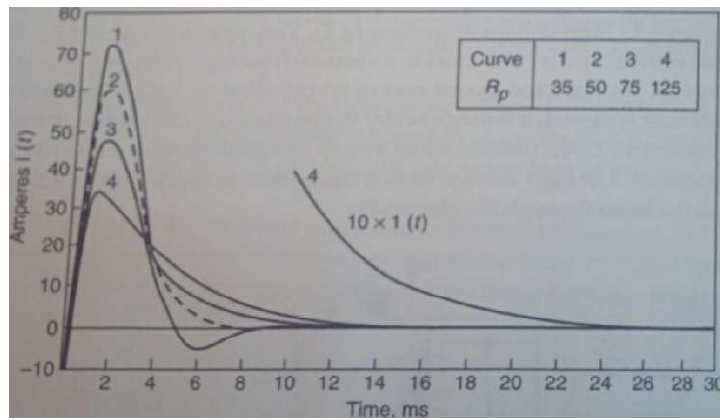

## IMPLANTABLE DEFIBRILLATORS

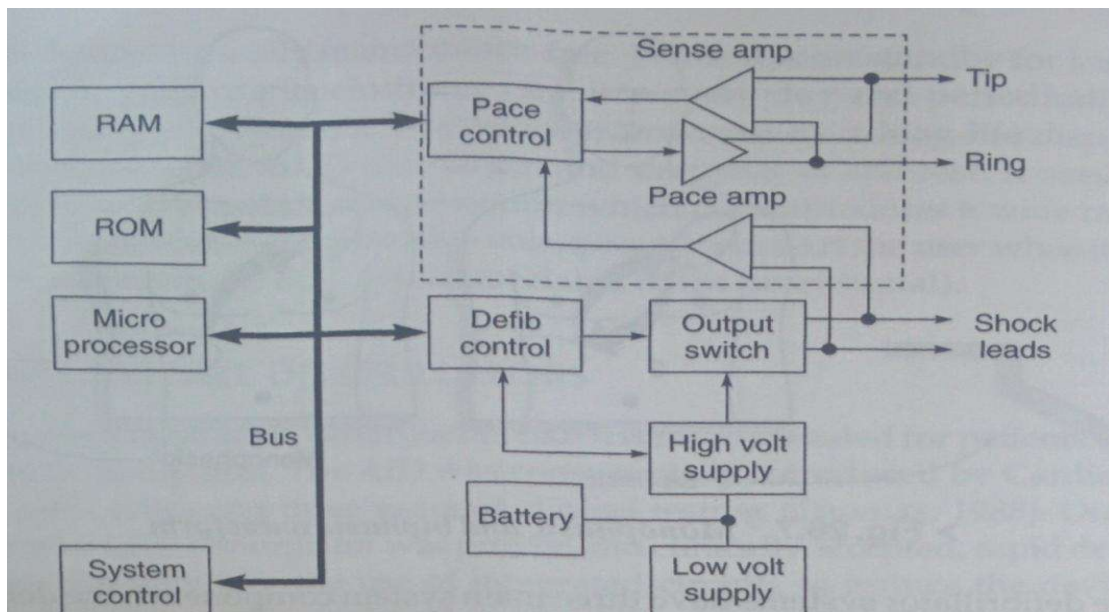

- An implantable defibrillator continuously monitors a patient's heart rhythm.
- If the device detects fibrillation, the capacitors within the device are charged up to 750 V. The capacitors are then discharged into the heart, which mostly represents a resistive load of 50  $\Omega$ , to bring the heart into normal rhythm.
- This may require the delivery of more than one high-energy pulse.
- Implantable defibrillator systems have three main system components: the defibrillator itself (AID), the lead system, and the programmer recorder/monitor (PRM). The AID houses the power source, sensing, defibrillation, pacing, and telemetry communication system. The lead system provides physical and electrical connection between the defibrillator and the heart tissue. The PRM communicates with the implanted AID and allows the physician to view status information and modify the function of the device as needed.

### Programmer Recorder/Monitor (PRM):

- The PRM is an external device that provides a bidirectional communications link to an implanted AID. This telemetry link is established from a coil within the wand of the PRM to a coil within the implanted device. This telemetry channel may be used to retrieve real-time and stored intracardiac ECG, therapy history, battery status, and other information pertaining to device function. A number of combinations of programmable therapy and detection options are available, and it is not unusual to alter these prescriptions dozens of times over the life of the implant.

### Leads:

- Until recently, the defibrillating high energy pulse was delivered to the heart via a 6 cm x 9 cm titanium mesh patch with electrodes placed directly on the external surface of the heart. Sensing was provided through leads screwed in the heart. This approach required an invasive surgical approach to provide access to the heart. The modern implantable defibrillators make use of a single transvenous lead with the multiple electrodes inserted into the right ventricle for ventricular pacing and defibrillation.

### **Pulse Generator**

- It has a microprocessor which controls overall system functions. An 8-bit device is sufficient for most systems. **ROM** provides non-volatile memory for system start-up tasks and some program space, whereas RAM is required for storage of operating parameters, and storage of electro-cardiogram data. The system control part includes support circuitry for the microprocessor like a telemetry interface, typically implemented with a UART-like (universal asynchronous receiver/transmitter) interface and general-purpose timers.
- The power supply to the circuit comes from lithium Silver Vanadium oxide (Li SVO) batteries. Digital circuits operate from 3 V or lower supplies whereas analog circuits typically require precision nanoampere current source inputs. Separate voltage supplies are generated for pacing (approximately 5 V) and control of the charging circuit (10-15 V),
- High power circuits convert the 3-6 V battery voltage to the 750 V necessary for a defibrillation pulse, store the energy in high voltage capacitors for timed delivery, and finally switch the high voltage to cardiac tissue or discharge the high voltage internally if the cardiac arrhythmia self-terminates. The major components of these circuits are the battery, the DC-to-DC converter, the output storage capacitors, and the high-power output switches.
- Commercially available implantable defibrillators all utilize lithium SVO cells, with the most common configuration being two connected in series to form an approximately 6 V battery. Unlike 2.8 V lithium iodide (LI) pacemaker cells which develop high internal impedance as they discharge (up to 20,000  $\Omega$  over their useful life), SVO cells are characterized by low internal impedance (less than 1  $\Omega$ ) over their useful life. The output voltage of SVO is higher than LI ranging from 3.2 V for a fresh cell to approximately 2.5 V when nearly depleted.
- DC to DC converter used to convert the 6 volt battery voltage to 750 V is of classical configuration. They are operated at as high a frequency (in the range of 30-60 KHz) as practical to facilitate the use of the smallest possible core.
- The storage capacitors are typically aluminium electrolytics because of the high volumetric efficiency and working voltage required. Most designs utilize at least two such capacitors in series.

### **Ventilators**

- An integral component of the anaesthetic delivery system is the ventilator. The ventilator provides a positive force for transporting respiratory and anaesthetic gases into an apneic patient. The ventilators provide positive pressure ventilation at a controlled minute volume (Tidal volume, Rate). They operate either electronically or mechanically with pneumatic or electric power source.
- Anaesthetic machine ventilators have a minimal number of controls. The anaesthetist could vary minute volume by setting tidal volume and ventilatory frequency directly or by adjusting inspiratory time, inspiratory flow rate and the ratio of inspiratory to expiratory time. The newest models resemble critical care ventilators in their capabilities.
- These may perform self-test upon start-up, volume or pressure-controlled ventilation modes, assisted spontaneous ventilation and electronically adjustable PEEP. Sophisticated spirometry compensates for changes in fresh gas flow, small leaks or patient compliance.
- Most of the currently used ventilators consist of a bellows contained within another housing.
- The bellows communicate directly with the breathing circuit and causes a pre-selected volume of gas to flow into the patient. The flow of gas into the circuit results from collapsing the

ventilator bellows by pressurizing the surrounding gas volume contained within the bellows housing.

- The ventilator is either located within the mainframe of the anaesthesia machine or is attached as an accessory unit. The outlet of the ventilator connects directly to the patient breathing circuit of the anaesthetic delivery system at the location and in place of the breathing reservoir bag. The ventilator thus functions as a controller for both ventilation and circuit gas supply by replacing the functions of the reservoir bag and APL valve.
- When artificial ventilation needs to be maintained for a long time, a ventilator is used. Ventilators are also used during anaesthesia and are designed to match human breathing waveform/pattern.
- These are sophisticated equipment with a large number of controls which assist in maintaining proper and regulated breathing activity. For short-term or emergency use, resuscitators are employed. These depend upon mechanical cycle operation and are generally light-weight and portable.
- The main function of a ventilator is to ventilate the lungs in a manner as close to natural respiration as possible. Since natural inspiration is a result of negative pressure in the pleural cavity generated by the movement of the diaphragm, ventilators were initially designed to create the same effect. These ventilators are called negative-pressure ventilators. In this design, the flow of air to the lungs is facilitated by generating a negative-pressure around the patient's thoracic cage. The negative-pressure moves the thoracic walls outward, expanding the intrathoracic
- Volume and dropping the pressure inside the lungs, resulting in a pressure gradient between the atmosphere and the lungs which causes the flow of atmospheric air into the lungs.
- The inspiratory and expiratory phases of the respiration are controlled by cycling the pressure inside the body chamber.

**Positive-pressure ventilators** generate the inspiratory flow by applying a positive pressure—greater than the atmospheric pressure—to the airways. During the inspiration, the inspiratory flow delivery system creates a positive pressure in the patient circuit and the exhalation control system closes the outlet to the atmosphere. During the expiratory phase, the inspiratory flow delivery system stops the positive pressure at the exhalation system and opens the valves to allow the exhaled air to the atmosphere.

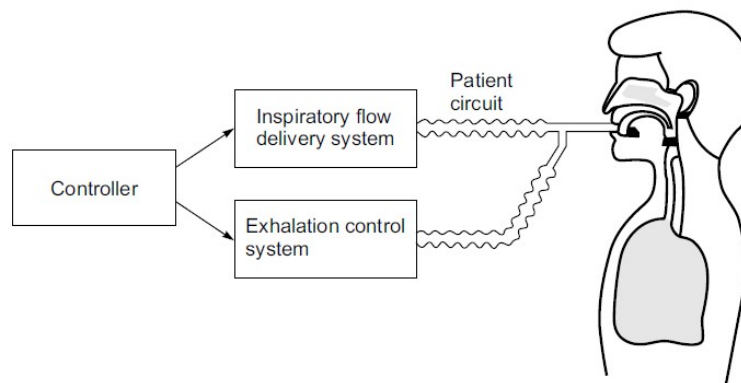

► Fig. 33.3 Functional diagram of a positive pressure ventilator

Positive-pressure ventilators operate either in mandatory or spontaneous mode. In spontaneous breath delivery, the ventilator responds to the patient's effort to breathe independently. Therefore, the patient can control the volume and the rate of respiration. Spontaneous breath delivery is used for those patients who are on their way to full recovery but are not completely ready to breathe from the atmosphere without mechanical assistance. When delivering mandatory breaths, the ventilator controls all parameters of the breath such as tidal volume, inspiratory flow waveform, respiration rate and oxygen content of the breath. Mandatory breaths are normally delivered to the patients who are incapable of breathing on their own



## TYPES OF VENTILATORS

**Anaesthesia Ventilators:** These are generally small and simple equipment used to give regular assisted breathing during an operation.

**Intensive Care Ventilators:** Intensive care ventilators are more complicated, give accurate control over a wider range of parameters and often incorporate 'patient triggering facility'.

## VENTILATOR TERMS

**Lung Compliance:** The compliance of the patient's lungs is the ratio of volume delivered to the pressure rise during the inspiratory phase in the lungs. This includes the compliance of the airways. Compliance is usually expressed as litres/cm H<sub>2</sub>O.

Lung compliance is the ability of the alveoli and lung tissue to expand on inspiration. The lungs are passive, but they should stretch easily to ensure the sufficient intake of the air. A ventilator and other parts of the breathing circuit also have compliance and some of the delivered volume is used to compress gas or expand gas in these parts.

The compliance of a patient's lungs is the ratio of pressure drop across the airway to the resulting flow rate through it. It is also expressed as cm H<sub>2</sub>O/litres (pressure drop/flow rate).

**Airway Resistance:** Airway resistance relates to the ease with which air flows through the tubular respiratory structures. Higher resistances occur in smaller tubes such as the bronchioles and alveoli that have not emptied properly.

**Mean Airway Pressure (MAP):** An integral taken over one complete cycle expresses the mean airway pressure. Inspiratory Pause Time: When the pressure in the patient circuit and alveoli is equal, there is a period of no flow. This period is called inspiratory pause time.

**Inspiratory Flow:** Inspiratory flow is represented as a positive flow above the zero line.

**Expiratory Flow:** Expiratory flow is a negative flow below the zero line.

**Tidal Volume:** Tidal volume is the depth of breathing or the volume of gas inspired or expired during each respiratory cycle

**Minute Volume:** This refers to volume of gas exchanged per minute during quiet breathing.

Minute volume is obtained by multiplying the tidal volume by the breathing rate.

## CLASSIFICATION OF VENTILATORS

- Based on the Method on Inspiratory Phase
- Based on Power Transmission
- Based on Pressure Pattern
- Based on the Type of Safety Limit
- Based on Cycling Control
- Cycling from Inspiration to Expiration
- Cycling from Expiration to Inspiration
- Based on the Source of Power

## MODERN VENTILATORS

The current and future trends in critical care ventilatory management demand precise flow, pressure and oxygen control for application to both adult and paediatric patients. Modern ventilator machines consist of two separate but inter-connected systems:

The pneumatic flow system

An electronic control system.

- The pneumatic flow system enables the flow of gas through the ventilator. Oxygen and medical grade air enter the ventilator at 3.5 bar (50 psi) pressure through built-in 0.1-micron filters. The normal operating range is 2 to 6 bar or 28 to 86 psi. These gasses enter the air/oxygen mixer where they combine at the required percentage and reduced in pressure to 350 cm H<sub>2</sub>O.
- The gasses then enter a large reservoir tank which holds about 8 litres of mixed gasses, when compressed to 350 cm H<sub>2</sub>O. An electronically controlled flow valve proportions the gas flow from the reservoir tank to the patient breathing circuit. In some ventilators, an air compressor is used in place of a compressed air tank. The primary objective of the device is to ensure proper



level of oxygen in the inspiratory air and deliver a tidal volume according to the clinical requirements.

- As the gasses leave the ventilator, they pass by an oxygen analyser, a safety ambient air inlet valve and a back-up mechanical over pressure valve. The ambient valve provides the patient the ability to breathe room air when the ventilator fails or the pressure in the patient circuit drops below  $-10$  cm of H<sub>2</sub>O. In the patient breathing circuit is a bi-directional flow sensor to measure the gas flows. The exhaled gasses exit through an electronically controlled exhalation valve located at the ventilator. The microprocessor controls each valve to deliver the desired inspiratory air and oxygen flows for mandatory and spontaneous ventilation.
- The electronic control system may use one or more microprocessors and software to perform monitoring and control functions in a ventilator. These parameters include setting of the respiration rate, flow waveform, tidal volume, and oxygen concentration of the delivered breath, peak flow and PEEP. The PEEP selected in the mandatory mode is only used for control of exhalation flow. The microprocessor utilizes the above parameters to compute the desired inspiratory flow trajectory. The system consists of monitors for pressure flow and oxygen
- Fraction. The sensors are connected to electronic processing circuits which makes them available for digital readouts. The signals are also compared with pre-set alarm levels so that if they fall outside a pre-determined normal range, alarms are sounded.
- The flow sensor usually consists of a variable orifice and by measuring the pressure drop across the variable orifice, the patient flows can be calculated. Ventilators are lifesaving equipment and therefore need regular maintenance and calibration.

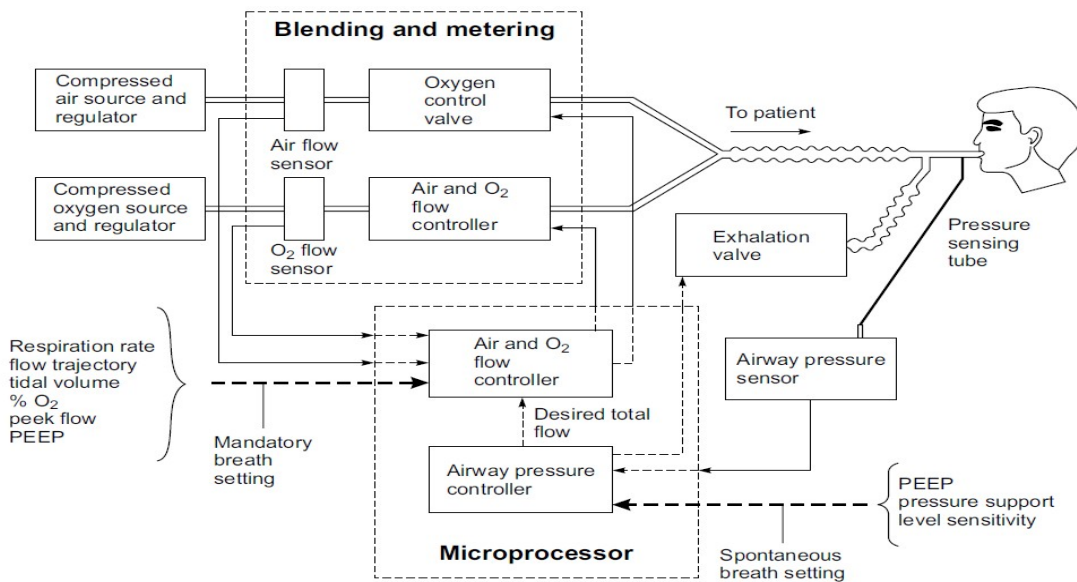

► Fig. 33.12 Block diagram of a microprocessor controlled ventilator

- The most common indices of the ventilation apparatus are the absolute volume and changes of volume of the gas space in the lungs achieved during a few breathing manoeuvres. The ventilator is constantly monitored and adjusted to maintain appropriate arterial pH and PaO<sub>2</sub>.
- This system requires a set of sensors for pressure, volume and flow. The information from the sensors modulates the operations in the microcontroller unit (MCU). This MCU receives information from the airways, lungs and chest wall through the sensors and decides how the ventilator pump responds.

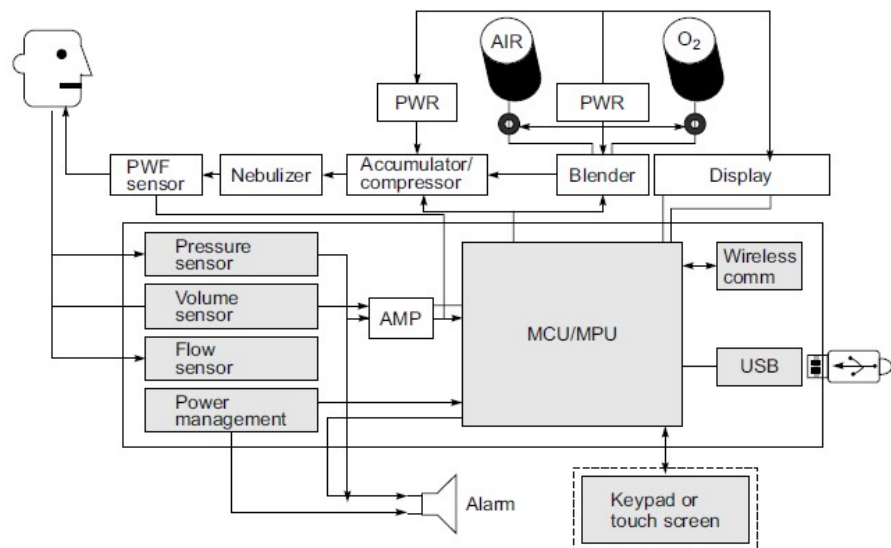

- The signal that shows lung volume is a differential signal, but this is not the signal measured
- Directly from the lungs using transducer. The air and oxygen blender provides a precise oxygen concentration by mixing air and oxygen.
- Internally, a proportioning valve mixes the incoming air and oxygen as the oxygen percentage dial is adjusted. Variation in line pressure, flow or pressure requirements for any attached device will not affect the oxygen concentration. The MCU uses a PWM (Pulse Width Modulator) to control the blender electro valves through a motor control design.
- An important part of the circuit is an alarm system that can indicate different patient parameters such as exhaled volume or airway pressure.
- The ventilation system must be able to detect whether a breath has been taken. The MCU measures changes in aspiratory flow and pressure by using sensors. If no inspiration is detected within a certain period of time, the monitor sounds an alarm. The conditions to be programmed depend on each system. PWM cycles can be programmed to sound the alarms.

### Nerve Simulator

Electrical nerve stimulation is an option for individuals who have unsuccessfully tried other pain management options. It is especially useful for those who experience failed back surgery, complex regional pain syndrome, seizures or multiple sclerosis.

Nerve stimulators can be a useful option when chronic pain doesn't respond to physical therapy, medication or surgery.



### Types of Nerve Simulator

- Transcutaneous electrical nerve stimulation (TENS)
- peripheral nerve stimulation (PNS)
- spinal cord stimulation (SCS)

## Transcutaneous electrical nerve stimulation

- Transcutaneous electrical nerve stimulation (TENS) is a therapy that uses low voltage electrical current to provide pain relief. A TENS unit consists of a battery-powered device that delivers electrical impulses through electrodes placed on the surface of your skin. The electrodes are placed at or near nerves where the pain is located or at trigger points.
- There are two theories about how transcutaneous electrical nerve stimulation (TENS) works.
- One theory is that the electric current stimulates nerve cells that block the transmission of pain signals, modifying your perception of pain.
- The other theory is that nerve stimulation raises the level of endorphins, which are the body's natural pain-killing chemical. The endorphins then block the perception of pain.
- TENS therapy has been used or is being studied to relieve both chronic (long lasting) and acute (short-term) pain.



## Peripheral nerve stimulation (PNS)

- Peripheral nerve stimulation, frequently referred to as PNS, is a commonly used approach to treat chronic pain.
- It involves surgery that places a small electrical device (a wire-like electrode) next to one of the peripheral nerves. (These are the nerves that are located beyond the brain or spinal cord). The electrode delivers rapid electrical pulses that are felt like mild tingles (so-called paresthesias).
- During the testing period (trial), the electrode is connected to an external device, and if the trial is successful, a small generator gets implanted into the patient's body. Similar to heart pacemakers, electricity is delivered from the generator to the nerve or nerves using one or several electrodes.
- The patient is able to control stimulation by turning the device on and off and adjusting stimulation parameters as needed

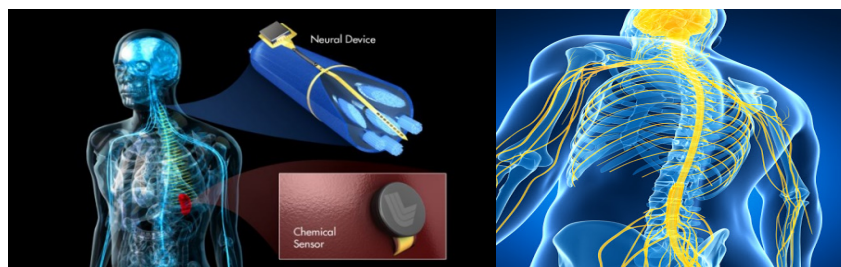

## Spinal cord stimulation (SCS)

- A spinal cord stimulator (SCS) device is surgically placed under your skin and sends a mild electric current to your spinal cord.
- The spinal cord device consists of a pulse generator, a small wire that carries the current from a pulse generator to the nerve fibers of the spinal cord.
- When turned on, the SCS stimulates the nerves in the area where your pain is felt. Pain is reduced when the electrical pulses modify and mask the pain signal from reaching your brain.
- SCS therapy is designed to help treat chronic, ongoing pain.

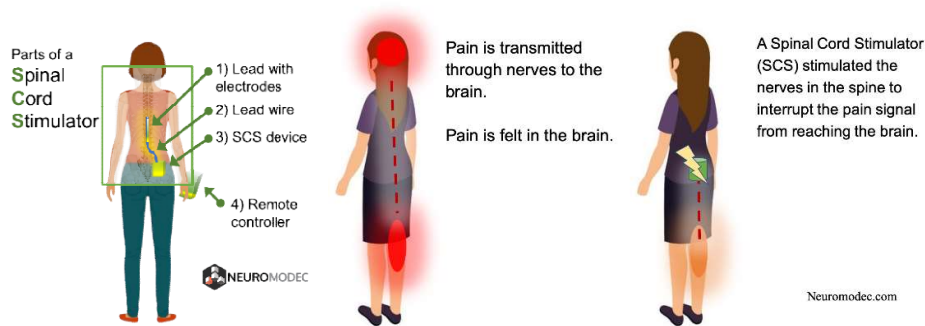

Spinal cord stimulation is a therapy that masks pain signals before they reach the brain. A small device, similar to a pacemaker, is implanted in the body to deliver electrical pulses to the spinal cord. It helps people better manage their chronic pain symptoms and decrease the use of opioid medications. It may be an option if you suffer chronic back, leg or arm pain and have not found relief with other therapies.

### Muscular Simulator

Electrical muscle stimulation (EMS) is a type of electrotherapy stimulates a muscle contraction using electrical impulses in order strengthen weak muscles, reduce swelling, relieve pain and help heal wounds.

Neuromuscular electrical stimulation (NMES) uses high intensities that cause excitation of peripheral nerves to produce a muscle contraction. The impulses are generated by a device and delivered through electrodes (pads that adhere to the skin) over the middle of the muscles that require stimulating. The impulses from EMS mimic the action potential (stimulus required to make the muscle contract) coming from the central nervous system. This causes the muscles to contract.

There are several uses for EMS and NMES which include:

- **Pain relief.** EMS can be used at low levels to reduce the amount of pain you experience. This can be done by modulating the amount of pain signals to the brain or releasing natural pain-killers called endorphins.
- **Muscle contraction.** EMS can be used at different intensities to stimulate a muscle or help maintain muscle tone.



### SURGICAL DIATHERMY

Diathermy is a therapeutic treatment most commonly prescribed for muscle and joint conditions. It uses a high-frequency electric current to stimulate heat generation within body tissues.

#### PRINCIPLE OF SURGICAL DIATHERMY

High frequency currents, apart from their usefulness for therapeutic applications, can also be used in operating rooms for surgical purposes involving cutting and coagulation. The frequency of currents used in surgical diathermy units is in the range of 1–3 MHz in contrast with much higher frequencies employed in short-wave therapeutic diathermy machines. The power levels required for electrosurgery are below the threshold of neural stimulation provided that the diathermy frequency is in the radio-frequency range. This then allows the exclusive utilization of the thermal effect in high frequency surgery providing both the applications for cutting and coagulation.

Surgical diathermy machines depend on the heating effect of electric current. When high frequency current flows through the sharp edge of a wire loop or band loop or the point of a needle into the tissue, there is a high concentration of current at this point.

The tissue is heated to such an extent that the cells which are immediately under the electrode, are torn apart by the boiling of the cell fluid. The indifferent electrode establishes a large area contact with the patient and the RF current is therefore, dispersed so that very little heat is developed at this electrode. This type of tissue separation forms the basis of electrosurgical cutting.

**Electrosurgical coagulation** of tissue is caused by the high frequency current flowing through the tissue and heating it locally so that it coagulates from inside. The coagulation process is accompanied by a greyish-white discoloration of the tissue at the edge of the electrode.

**Fulguration** refers to a superficial tissue destruction without affecting deep-seated tissues. This is undertaken by passing sparks from a needle or a ball electrode of small diameter to the tissue. When the electrode is held near the tissue without touching it, an electric arc is produced, whose heat dries out the tissue. Fulguration permits fistulas and residual cysts to be cauterized and minor haemorrhages to be stopped.

**Desiccation**, needle-point electrodes are stuck into the tissue and then kept steady. Depending upon the intensity and duration of the current, a high local increase in heat will be obtained. The tissue changes due to drying and limited coagulation

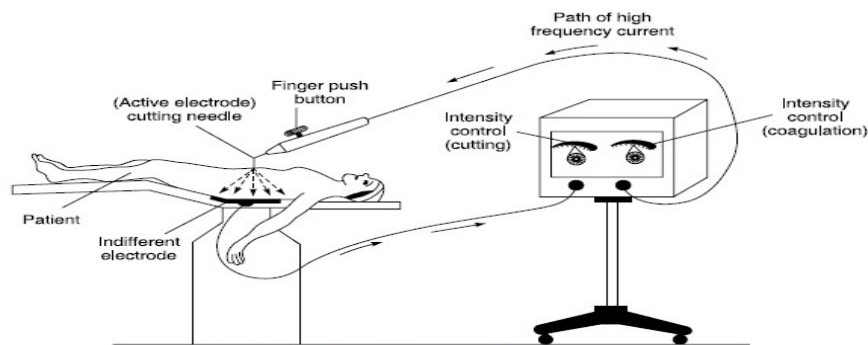

► Fig. 27.1 Principle of surgical diathermy machine

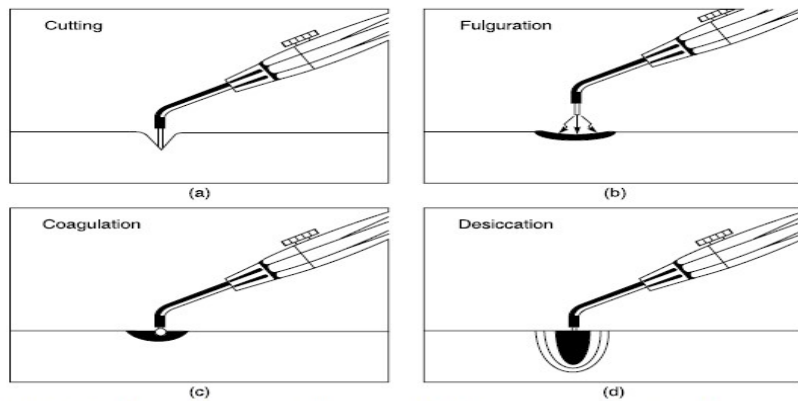

► Fig. 27.2 Various types of electro-surgery techniques commonly employed in practice

The concurrent use of continuous radio-frequency current for cutting and a burst wave radiofrequency for coagulation is called **Haemostasis** mode.

Different types of waveforms have been used to produce different effects for surgical procedures.



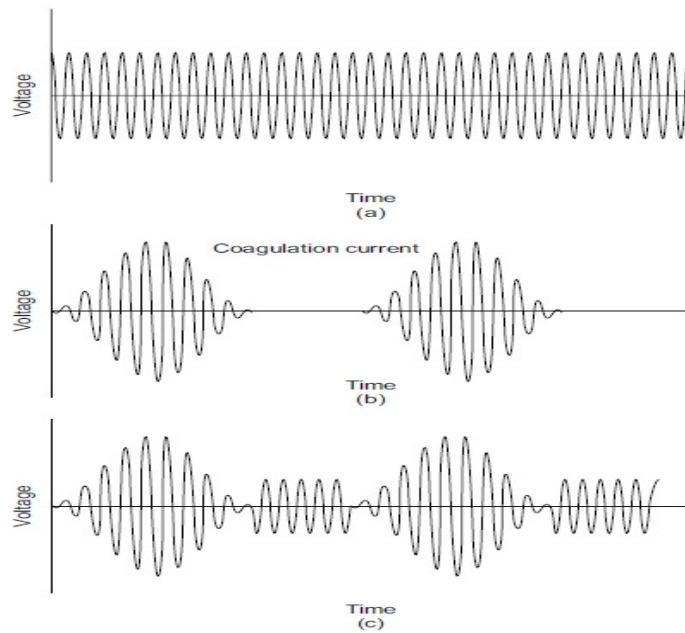

## SURGICAL DIATHERMY MACHINE

Surgical diathermy machine consists of a high frequency power oscillator. The earlier types of diathermy machines consisted of spark-gap oscillators whereas the current practice is to use thermionic valves or solid-state oscillators. A majority of the earlier units have access to both these power sources, viz. an RF generator and a spark-gap generator.

The RF generator provides an undamped high frequency current (typically 1.75 MHz) which is suitable for making clean cuttings.

The spark-gap generator produces damped high frequency current which is specifically suitable for the coagulation of all kinds of tissues. The mixing of both these currents signifies one of the most important possibilities for use in electrosurgery. By blending the currents of the tube and spark-gap generator, the degree of coagulation of wound edges may be chosen according to the requirements.

Solid-state generators have replaced a substantial number of vacuum tube and spark-gap units. Disposable, self-adhering dispersive electrodes (generally known as 'ground pads') are now widely used in place of the large area buttplate.

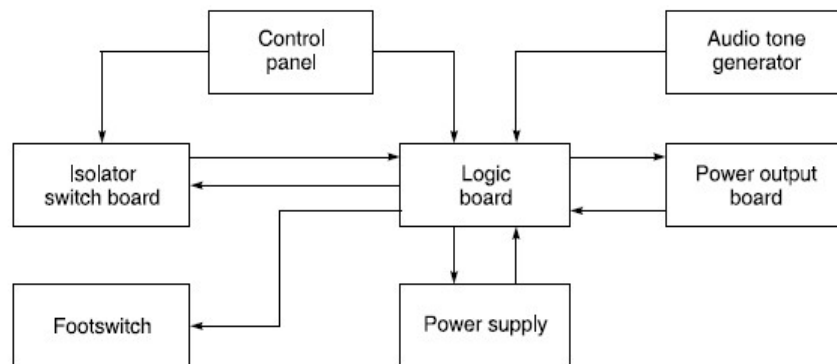

► Fig. 27.4 Block diagram of solid state electro-surgical unit

The heart of the system is the logic and control part which produces the basic signal and provides various timing signals for the cutting, coagulation and haemostasis modes of operation. An astable multivibrator generates 500 kHz square pulses. The output from this oscillator is divided into a number of frequencies by using binary counters.

These are the frequencies which are used as system timing signals. A 250 kHz signal provides a split phase signal to drive output stages on the power output circuit. A 15 kHz gating signal produces the

repetition rate for the three cycles of the 250 kHz signal which make up the coagulating output. The pulse width of this output is set at about 12  $\mu$ s.

The 250 kHz signal used for cutting is given to power output stage where it controls the push-pull parallel power transistor output stage. The output of this high power push-pull amplifier is applied to a transformer which provides voltage step-up and isolation for the output signal of the machine.

The modern machines employ both bi-polar junction transistors and power metal oxide-semiconductor field-effect transistors (MOSFET) in a cascade configuration or the use of a bridge connection of MOSFETs.

For identification of each mode of operation, the machines incorporate an audio tone generator. The tone signals are derived from the counter at 1 kHz (coagulation), 500 Hz (cutting) and 250 Hz (haemostasis). The isolator switch provides isolated switching control between the active hand switch and the rest of the unit. A high frequency transformer coupled power oscillator is used in which isolated output winding produces a DC voltage. The load put on the DC output by the hand switch is reflected back to the oscillator, accomplishing isolated switching. Logic circuits are used to receive external control signals and to operate the isolating relays, give visual indications and determine the alarm conditions.

The logic circuits receive information from the foot-switch, finger switch and alarm sensing points. A thermostat is sometimes mounted on the power amplifier heat sink. In case of overtemperature, it becomes open-circuited, signalling an alarm and interrupting the output.

The output circuit in the diathermy machine is generally isolated and carefully insulated from low frequency primary and secondary voltages. Blocking capacitors serve to effectively prevent any low frequency from appearing in the output circuit, and the isolated output reduces the possibility of burns due to an alternate path to ground.

Complaints of electrical shock during surgery can almost always be attributed to muscle contractions of the patient. This is caused by the rectification of the high frequency energy at the junction of the active electrode and the tissue in the presence of an arc, which is the actual means of performing electro surgery. This phenomenon is observed most when operating in a site of sensitive nerve tissue. However, no danger to the patient or to the operator due to this action

It is advisable to avoid contacts with conducting surfaces by those who happen to be near the machine or cables. Solid-state machines mostly incorporate an independent bi-polar RF generator for microsurgery procedures offering a fine output power control. The output waveform is a damped sinusoid at a repetition frequency

### **Automated Electrosurgical Systems**

With a conventional electrosurgical unit, there is a considerable fluctuation of the output voltage throughout the 3-s period of the cut. The cause of this undesirable fluctuation is linked to the following factors:

- Size and Shape of the Cutting Electrode: The conditions are different for the generator if, for instance, cutting is performed with electrode of large surface area or with a fine needle.
- Type and Speed of Cut: The cutting quality is determined by the speed with which the electrode is moved (quick or slow) and by the type of cut (superficial or deep)
- Different Tissue Properties: The tissue itself has a strong influence on the quality of the cut.

The variations in the output voltage due to the above factors considerably affect the quality of the cut. At times, the maximum output voltage can become so high (above 600°C) that severe carbonization occurs. Conversely, the minimum value of the output voltage can become so low (below 200°C) that cutting action is not achieved. In order to overcome this problem, microprocessor-controlled automated systems have been developed so that the output voltage or the spark intensity remains constant. In this machine, the variables—current, tissue resistance, voltage and spark intensity—are registered by means of an inbuilt sensor system and then processed as defined output signals.

The automatic control operates on two different criteria:

- Voltage control: whereby the selected voltage is controlled and held constant.



– Spark control: by which the selected spark intensity is held constant.

Electrosurgical generators use closed-loop control loops to adjust the voltage and current to keep the output power constant as the active monopolar electrode moves through tissues of varying impedance

The control of spark intensity is relatively complex because of its non-linear nature.

The design of the control system ensures that the cutting quality is independent of size and shape of the electrode, the type and speed of the cut and the varying tissue properties

Apart from ensuring a good quality of the cut, the microprocessor-controlled machine also provides the following coagulation modes:

- Soft coagulation
- Forced Coagulation
- Spray Coagulation

### Electrodes Used with Surgical Diathermy

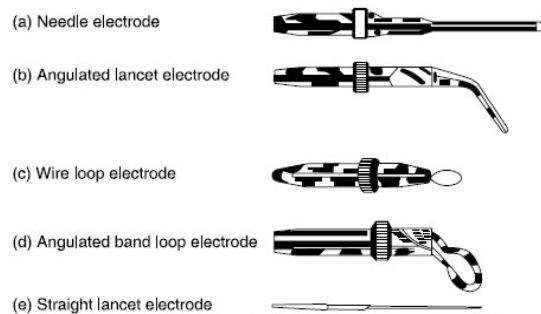

► Fig. 27.8 Cutting electrodes used with diathermy machine (a) needle electrode (b) angulated lancet electrode (c) wire loop electrode (d) angulated band loop electrode (e) straight lancet electrode

### SAFETY ASPECTS IN ELECTROSURGICAL UNITS

The risks associated with electrosurgery fall into four main categories viz. burns, electrical interference with the heart muscles (ventricular fibrillation), the danger of explosions caused by sparks and electrical interference with pacemakers and other medical electronic equipment

### Heart-Lung Machine

- Heart-Lung Machine is also called as Cardiopulmonary bypass machine in Medical terms.
- Cardiopulmonary bypass can be defined as a technique in which a machine temporarily takes over the function of the heart and lungs during surgery, maintaining the circulation of blood and the oxygen content of the patient's body.
- Cardiopulmonary bypass machines are operated by perfusionists to bypass the heart and lungs during open heart surgery. Blood returning to the heart is diverted through a heart-lung machine (a pump-oxygenator) before returning it to the arterial circulation. The machine does the work both of the heart (pump blood) and the lungs (supply oxygen to red blood cells).

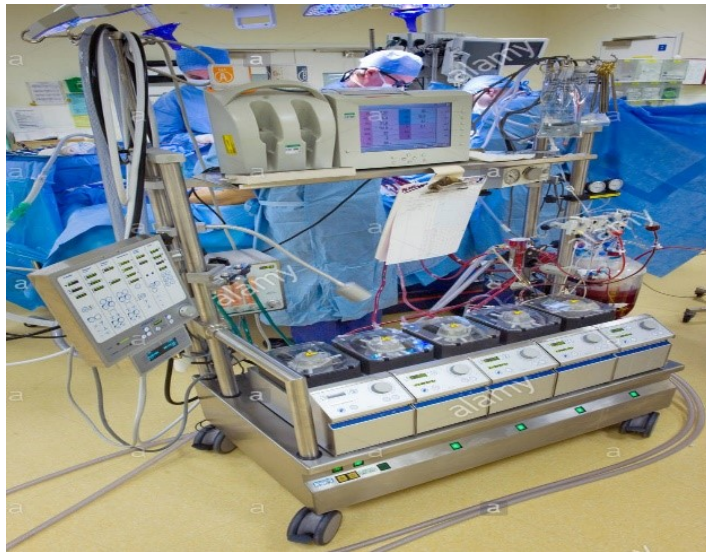

### Components

- Cardiopulmonary bypass consists of two main components, the pump and the oxygenator which remove oxygen-deprived blood from a patient's body and replace it with oxygen-rich blood through a series of hoses. The components of the CPB circuit are interconnected by a series of tubes made of silicone rubber or PVC. The pump console usually comprises several rotating motor-driven pumps that peristaltically "massage" tubing. This action gently propels the blood through the tubing. This is commonly referred to as a roller pump, or peristaltic pump. Many CPB circuits now employ a centrifugal pump for the maintenance and control of blood flow during CPB. By altering the speed of revolution (RPM) of the pump head, blood flow is produced by centrifugal force. This type of pumping action is considered to be superior to the action of the roller pump by many because it is thought to produce less blood damage (Haemolysis, etc.).
- Oxygenator: The oxygenator is designed to transfer oxygen to infused blood and remove carbon dioxide from the venous blood. Cardiac surgery was made possible by CPB using bubble oxygenators, but membrane oxygenators have supplanted bubble oxygenators since the 1980s. Membrane oxygenators consist of hollow microporous polypropylene fibres (100–200  $\mu\text{m}$  internal diameter). Blood flows outside the fibre while gases pass inside the fibre, thus separating the blood and gas phases. They have lesser propensity for air embolism and give greater accuracy in blood gas control. Newer designs have an integrated filter to manage emboli, thus making additional arterial filters unnecessary. Another type of oxygenator gaining favour recently is the heparin-coated blood oxygenator which is believed to produce less systemic inflammation and decrease the propensity for blood to clot in the CPB circuit. A heat exchanger is integrated with the oxygenator and placed proximal to it to reduce the release of gaseous emboli due to alterations in the temperature of saturated blood.
- During CPB, venous blood is drained through gravity into a reservoir. The pump moves blood from the reservoir to the oxygenator through a heat exchanger, before returning it to the arterial circulation. Additional components include suckers (to remove blood from surgical field), vents (to decompress the heart), haemofilters (for ultrafiltration) and cardioplegia system.

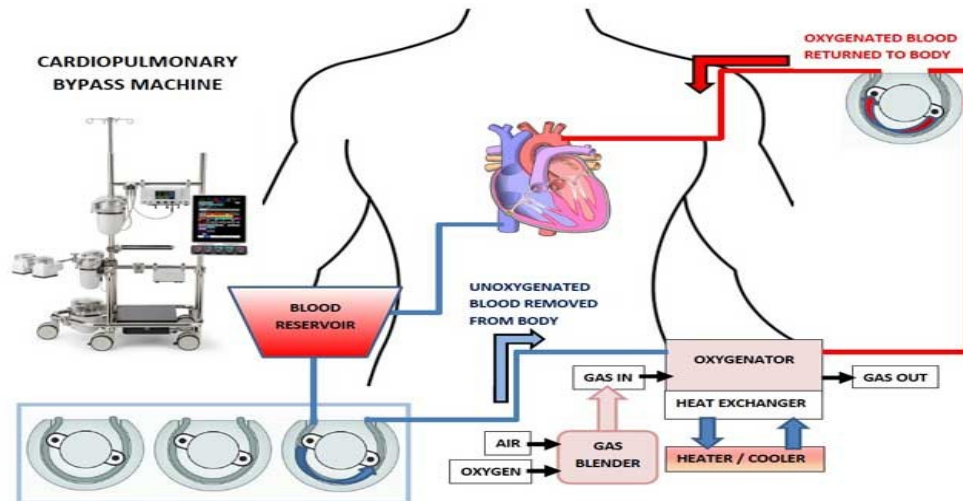

- Multiple cannulae are sewn into the patient's body in a variety of locations, depending on the type of surgery. A venous cannula removes oxygen deprived blood from a patient's body. An arterial cannula is sewn into a patient's body and is used to infuse oxygen-rich blood. A cardioplegia cannula is sewn into the heart to deliver a cardioplegia solution to cause the heart to stop beating.
- A CPB circuit consists of a systemic circuit for oxygenating blood and re-infusing blood into a patient's body (bypassing the heart); and a separate circuit for infusing a solution into the heart itself to produce cardioplegia (i.e. to stop the heart from beating), and to provide myocardial protection (i.e. to prevent death of heart tissue).
- A CPB circuit must be primed with fluid and all air expunged before connection to the patient. The circuit is primed with a crystalloid solution and sometimes blood products are also added. The patient must be fully anticoagulated with an anticoagulant such as heparin to prevent massive clotting of blood in the circuit.

### AUDIOMETER

An Audiometer is a specialized equipment, which is used for the identification of hearing loss in individuals, and the quantitative determination of the degree and nature of such a loss. It is essentially an oscillator driving a pair of headphones and is calibrated in terms of frequency and acoustic output. Both frequency and output are adjustable over the audio range. The instrument is also provided with a calibrated noise source and bone-conductor vibrator.



Audiometers may be divided into two main groups on the basis of the type of stimulus they provide to elicit auditory response:

- **Pure-tone audiometers**
- **Speech audiometers.**

A pure-tone audiometer is used primarily to obtain air-conduction and bone-conduction thresholds of hearing. These thresholds are helpful in the diagnosis of hearing loss. Pure-tone screening tests are employed extensively in industrial and school hearing conservation programmes.

Speech audiometers are normally used to determine speech reception thresholds for diagnostic purposes and to assess and evaluate the performance of hearing aids.

Screening audiometers are used to separate two groups of people. One that can hear as well as or better than a particular standard and the other that cannot hear so well.

In conventional pure-tone audiometry, head phones are worn by the subject and a set of responses is obtained for air-conducted sounds directed to each ear in turn. A bone conductor vibrator can then be attached to the head at the centre forehead position to see whether the hearing threshold improves. If it does, then the disorder is most likely wholly or partly conductive in origin. To avoid stimulation of the ear not under test with the vibrator, it can be temporarily made deaf by introducing a suitable masking noise in the non-test ear via an earphone. A narrow-band noise centred on the pure-tone test frequency or a wide-band white noise is used for this purpose.

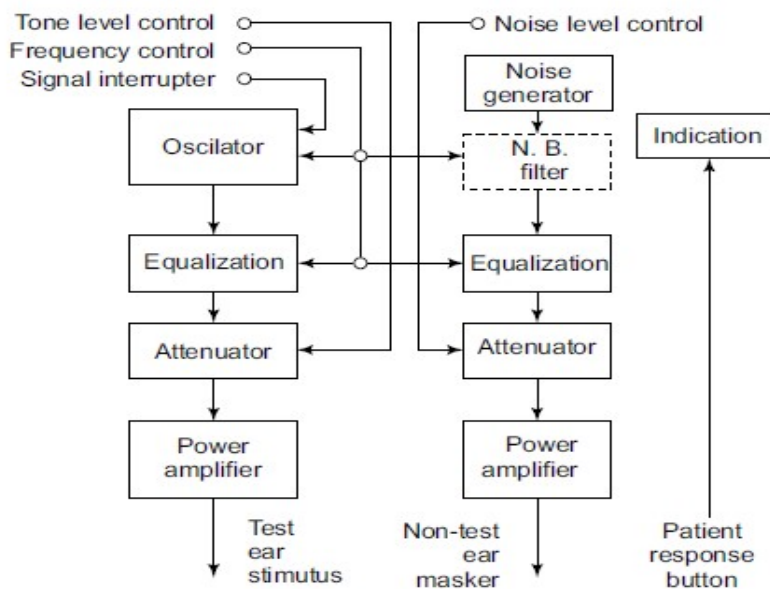

► Fig. 17.6 Block diagram of a basic audiometer (Adapted from Patel and Pandey, 2002)

The equalization circuit is required to provide frequency dependent attenuation in order to calibrate the output sound levels in dB HL and also to provide different amount of attenuation for different output devices used (headphone, loudspeaker, and vibrator). The attenuator, known as the hearing or tone level control, should be capable of controlling the output sound level over a desired range in steps of 5 dB. The output sound level should be within 3 dB of the indicated value.

For the masking purpose, the noise generator should provide wide band noise, which has energy spectrum equally distributed over the test frequency range

### Requirements of Audiometers

Modern audiometers are solid-state instruments covering a frequency range from approximately 100 to 10,000 Hz. Some instruments produce this range in discrete octave or semi-octave steps or intervals, while others provide for continuously variable frequency over their designed range. Automatic recording facilities include a continuous sweep frequency, the rate of change is normally kept as one octave per minute. If an automatic recording audiometer provides fixed frequencies

### PURE-TONE AUDIOMETER

A wave in air, which involves only one frequency of vibration, is known as pure-tone. Puretone audiometry is used in routine tests and, therefore, it is the most widely used technique for determining hearing loss. Pure-tone audiometers usually generate test tones in octave steps from 125 to 8000 Hz, the signal intensity ranging from -10 dB to +100 dB.

Pure-tone audiometry has several advantages, which makes it specifically suitable for making threshold sensitivity measurements. A pure-tone is the simplest type of auditory stimulus. It can be specified accurately in terms of frequency and intensity. These parameters can be controlled with a high degree of precision.

Pure-tone measurements at high frequencies prove to be a more sensitive indicator of the effect of such noise on the ear than speech tests. Changes in threshold sensitivity associated with various middle ear surgical procedures can be monitored more accurately with pure-tone than speech tests.

A pure-tone audiometer basically consists of an oscillator for having a precise control on the frequency of oscillations. The oscillator is coupled to an output current amplifier stage to produce the required power levels. The attenuators used in these instruments are of the ladder type. The signals are presented acoustically to the ear by an earphone or small loudspeaker.

• Table 17.1 Test Tones and Signal Intensity in Audiometers

Frequency	Pure-tone (head-phones)	Pure-tone (bone conduction)	Balance channel	Narrow band masking (head-phones)	Narrow band masking (bone conduction)
125	70	-	-	-	-
250	90	45	90	80	50
500	110	60	110	90	60
1000	110	60	110	90	60
1500	110	60	110	90	60
2000	110	60	110	90	60
3000	110	60	110	90	50
4000	110	60	110	90	50
6000	90	-	-	80	-
8000	90	-	-	80	-
Speech	110	-	110	-	-

## SPEECH AUDIOMETER

- Besides tonal audiometry, it is sometimes necessary to carry out tests with spoken voices.
- These tests are particularly important before prescribing hearing-aids and in determining the deterioration of speech understanding of patients. Specially designed speech audiometers are used for this purpose. They incorporate a good quality CD player, which can play recorded speech. Masking noise is supplied by the noise generator. The two channels supply the two head-phones or the two loudspeakers.
- The CD player has a capacity for recording a limitless variety of test material and a consistency of speech input, which cannot be obtained for live-voice audiometry in relation to test-retest repeatability. Another advantage of the recorded material is that the test words and sentences can be selected to cater for the widely differing needs of age, intelligence, dialect and language.
- In speech audiometers, live-voice facilities are incorporated primarily for communication purposes as the inherent unreliability of live-voice speech tests may lead to serious errors.
- The microphone amplifier used for this purpose is a simple two stage amplifier.
- The frequency response characteristics of a live-voice channel should be such that with the microphone in a free sound field having a constant sound pressure level

## Dialysers

- Dialysis machines are artificial kidney that perform most, but not all, kidney function for patients who have permanent or temporary renal failure
- The machine use HEMODIALYSIS to cleanse the blood and balance its constituents.

In HEMO DIALYSIS, blood is removing from the body and filtered through a manmade membrane called a dialyzer or artificial kidney and then the filtered blood is returned on the body. The average person has about 10 to 12 pints of blood during dialysis only one pint (about two cups) is outside of the body at a time High clearance of small and medium MW





- Properly functioning kidneys prevent extra water, waste, and other impurities from accumulating in your body. They also help control blood pressure and regulate the levels of chemical elements in the blood. These elements may include sodium and potassium. Your kidneys even activate a form of **vitamin D** that improves the absorption of calcium.
- When your kidneys can't perform these functions due to disease or injury, dialysis can help keep the body running as normally as possible. Without dialysis, salts and other waste products will accumulate in the blood, poison the body, and damage other organs.

A dialyzer is composed of a dialysis membrane and supporting structure three or four components. □ Blood compartment.

- Dialysate compartment.
- Semi permeable membrane separating
- Membrane support structure.

### Working

- Dialysis work on the principle of the diffusion of solutes and ultra-filtration of fluid across a Semi Permeable Membrane.
- The dialysis machine mixes and monitors the Dialysate. Dialysate is the fluid that helps remove the unwanted waste products from your blood.
- It also helps get your electrolytes and minerals to their proper levels in your body.
- The machine also monitors the flow of your blood while it outside of your body.

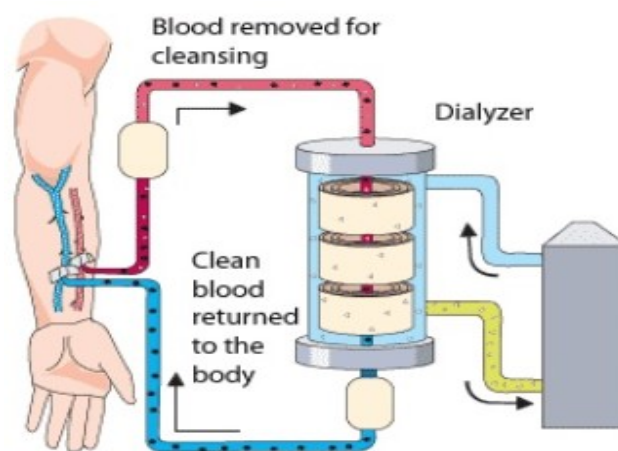

### Dialyzer Membrane Cellulose

Obtained from processed cotton (regenerated cellulose, cuprammonium cellulose, cuprammonium rayon and saponified cellulose) Substituted cellulose:

- Cellulose polymer has a large number of free hydroxyl group at its surface

- Free hydroxyl groups are responsible for blood cell activation causing bio-incompatibility of the dialyzer (cellulose acetate, cellulose diacetate, triacetate)

### Dialyzer Membrane Cellulosynthetic

A synthetic material (a tertiary amino compound) is added to liquefied cellulose during formation of the membrane as a result the surface of the membrane is altered and biocompatibility is increased (cellosyn or hemphan) Synthetics:

- Not cellulose based but are synthetic plastics and materials used include polyacrylonitrile (PAN) polysulfone, polycarbonate, polyamide and polymethyl-methacrylate (PMMA).
- The dialyzer, or filter, has two parts, one for your blood and one for a washing fluid called dialysate. A thin membrane separates these two parts. Blood cells, protein and other important things remain in your blood because they are too big to pass through the membrane. Smaller waste products in the blood, such as urea, creatinine, potassium and extra fluid pass through the membrane and are washed away.

### Dialyzer Types

#### COIL DIALYZER:

- Flattened cellulose tubing wrapped as a coil and through which patients' blood flows during dialysis.
- The blood channels were long to obtain the needed surface area, and resistance was high
- UF was unpredictable and blood leaks were frequent.

#### PARALLEL PLATE DIALYZER

Sheets of membrane are placed between supporting plates.

The plates have ridges and grooves to support the membrane and allow flow of dialysate along it □ Resistance to blood flow is low. The surface area varies from 0.25 to 1.5 msq.

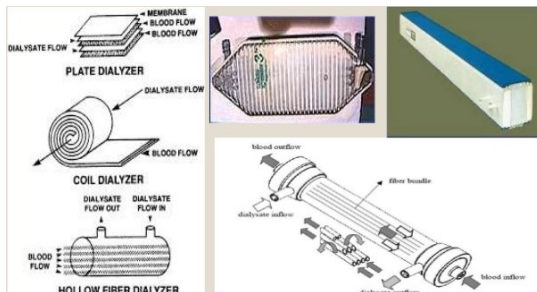

#### Advantage:

- Blood volume is about 50-100 ml at 100 mmHg increase with high TMP
- Heparin requirement usually low, minimal clotting in the blood compartment
- Ultrafiltration is reasonably predictable and controllable

#### Disadvantage:

- Formation of local thrombi around inlet and outlet ports and corners
- May lead to bacterial growth and endotoxin formation therefore plates are not often reused

#### HOLLOW FIBER DIALYZER

Numerous hollow fibers

Hollow fibers are tiny its diameter 150-250um

Number of fibers 20000 or more, depending upon length, kind of membrane and surface area of dialyzer **Advantage:**

- Low blood volume 60-90ml
- Resistance to blood flow is low
- Ultrafiltration can be precisely controlled
- Well adapted to reuse

#### Disadvantage:

- Deaeration of fiber predialysis is necessary to prevent air lock of the fibers



- More heparin is required for most of the patients

## REACTION TO MEMBRANES

### Type A reaction

- Within minutes of starting dialysis with
- Dyspnoea, wheeze
- A feeling of warmth, urticaria
- Cough, hypotension
- Collapse or cardiac arrest

### Type B reaction

- More common but much milder often occur 20-40 min after starting dialysis
- Usually cause back and chest pain

### Advantages

- Easy to cleaning and disinfecting
- The device has flow rate of blood UPTO 600 ml/min .
- Fluid exchanges batteries because to provide uninterruptable power supply

You need dialysis if your kidneys no longer remove enough wastes and fluid from your blood to keep you healthy. This usually happens when you have only 10 to 15 percent of your kidney function left. You may have symptoms such as nausea, vomiting, swelling and fatigue. However, even if you don't have these symptoms yet, you can still have a high level of wastes in your blood that may be toxic to your body. Your doctor is the best person to tell you when you should start dialysis.

### POST MCQ:

- \_\_\_\_\_ is natural Pacemaker in Human Heart
  - Right and left braches
  - Atrioventricular node (AV node)
  - Common AV Bundle
  - Sinoatrial node (SA Node)
 Answer: d
- \_\_\_\_\_ is most important in case of external pacemaker.
  - Power source Battery
  - Choice2Electrode types
  - Size and weight
  - All of the above
 Answer: c
- In dialysis the waste products are transferred to the dialysate by
  - Surface tension
  - Centrifuge
  - Diffusion
  - Viscosity variation
 Answer: c
- Most blood pumps use the principle of
  - Peristaltic compression
  - Centrifuge
  - Compression
  - Normal acceleration
 Answer: a
- During Myocardial Infarction, one can use
  - Heart lung machine
  - Pacemaker
  - Nerve stimulator
  - Kidney Machine

Answer: b

6. Suppose the pacemaker pulse has high energy and occurs during the vulnerable part of the T wave then the heart is in
- a) Normal state
  - b) Atrial fibrillation
  - c) Ventricular fibrillation
  - d) Low pressure

Answer: c

7. To produce ventricular contraction with an electric pulse, the minimum energy required is
- a)  $10\mu\text{J}$
  - b) 1J
  - c) 10 mW
  - d) 1W

Answer: a

8. Adams stokes attacks can be successfully treated with a
- a) Defibrillator
  - b) Nerve stimulator
  - c) Artificial heart valve
  - d) Pacemaker

Answer: d

9. \_\_\_\_\_ sends the electrical impulse that triggers each heartbeat.
- a) Left Branches
  - b) AV node
  - c) SA Node
  - d) Right Branches

Answer: c

10. Because of the risk of electromagnetic interference, pacemaker patients should not be given
- a) Cancer treatment
  - b) Diathermy treatment
  - c) Saline water
  - d) The rooms with fans

Answer: b